

Midwest

Early Ford

www.MidwestEarlyFord.com



1948-56 Ford Pickup Parts



**PICKUP
BEDS**
See page 91

February 2019

4.00

1-800-543-5035

HOW TO ORDER FROM THIS CATALOG

Phone

Orders: MasterCard, VISA and Discover cards accepted.

Phone: **Toll-Free Order Number 1-800-543-5035. Customer Service Number 937-325-2408.**

Our phone representatives are at your service Monday through Friday 8 a.m.-5 p.m. and Saturday 8:30-11:30 a.m.. Please have you part numbers ready.

Fax: **(937) 325-1900**

Fax your completed order form along with year, make and model of the vehicle you are ordering for and your credit card information. Be sure to include a daytime phone number (include area code).

Mail: **If possible use order forms found in this catalog**

Please list year, make and model of vehicle for which you are ordering, complete part numbers, and description. Include daytime telephone number (including area code). Provide complete address with street name and house number. Mail to Early Ford, 2141 W. Main St., Springfield, OH 45504.

Payment: Although personal checks are welcome, expect at least a two week delay in shipping to allow the check to clear the bank. Money orders, bank certified checks, MasterCard, VISA, Discover may also be used.

Free Standard size UPS Ground orders over \$1,000 are shipped free within the continental US.

Shipping: Free shipping does not apply to UPS oversize (exceeding 48") or overweight packages (exceeding 70 lbs.), back orders or truck freight items. Larger parts such as, but not limited to: Running Boards, Bumpers, Headliners, Pickup Beds, Fenders, Tailgates or Firewall Insulators, are not covered under the Free Shipping Offer.

Return Policy If you need to return an item, you must call our store for authorization. **All returns must be made within 30 days.** After 30 days all sales are considered final. No returns will be processed without a completed merchandise return authorization form and a copy of the invoice. All returns are subject to a 20% restocking fee. Returned parts must be shipped prepaid, in the original unmarked manufacturer's packaging, and in resalable condition. ***Special order items are not returnable.***

Claims: Inspect the merchandise upon arrival. All damage claims must be taken up with the carrier. Please keep merchandise in the original carton for carrier to inspect.

Due to supplier price increases and decreases, **PRICES SUBJECT TO CHANGE WITHOUT NOTICE.**

OHIO RESIDENTS

Add 7-1/4%
Sales Tax

STORE HOURS:

Monday-Friday 8:00 to 5:00
Saturday 8:30 to 11:30

Warranty: All merchandise is sold without warranty, either expressed or implied.

We do not accept nor are we responsible for, the manner in which any of the products in this catalog are used. Neither seller nor manufacturer shall be liable for any loss, injury or damage, direct or consequential, arising out of the use of, or the inability of the product. After use, the user shall assume all risk and liability whatsoever in connection therewith.

www.MidwestEarlyFord.com

Email us at: MidwestEFS@core.com

1948-56 FORD PICKUP INDEX

—A—			
Accelerator Parts	34, 37, 77	Cowl Patch Panels	75
Accelerator Pedal	37	Cowl Wiring Loom	50
Air Cleaner	119	Crankshaft Parts.....	21
Air Conditioning	126	Crossover Pipe	15
Alternator Bracket & Pulley	107	Cylinder Heads	118
Antenna	71	Cylinder Head Bolts	18
Anti-Rattler Kit	79	Cylinder Head Nut Covers	18, 118
Anti-Squeak Webbing	58	—D—	
Arm Rest	89	Dash Bezels	37
Axle Bumpers	9	Dash Inserts	114
Axle Parts	4	Dash Insulators	74
—B—		Dash Knobs	35, 36
Ballast Resistor	40	Dash Trim	86
Ball Stud for Spindle Arm	10	Data Plate	74
Battery Cables	49	Decals	77, 114
Battery Disconnect Switch	49	Dimmer Switch	42
Battery Related Parts	14, 15, 103	Dipsticks	23, 124
Battery Tray	14	Disc Brake Kits	112
Beauty Rings	3, 71	Distributor Cap	40
Bed Floor (Pickup)	96, 97	Distributor Primary Wire	40
Bed Sides	92, 100	Distributor Vacuum Advance	40
Bed Strips	97, 100	Division Bar	80
Belts (Fan & Generator)	30	Dome Light Parts	48
Bezels (Dash)	37	Door Bumpers	78
Blue Dots	46	Door Emblems	90
Body Mounts	14, 101, 102	Door Handle (Outside)	84
Bolts	18, 52-58, 79, 92, 94, 99, 108	Door Handle (Inside)	85
Books	131	Door Handle Pads	84
Brake & Clutch Pedal Pads	8	Door Hinges	83
Brake Cylinder (Front)	5	Door Hinge Pins	90
Brake Cylinder (Rear)	6	Door Latch	84
Brakes (Disc)	112	Door Lock	86
Brake Drums	3	Door Panels & Clips	89
Brake Hardware	5, 6, 8	Doors	104
Brake Hose	6	Door Seal Sets	79
Brake Lines	6	Dove Tails	83
Brake Lever Boots	123	Drag Link	10
Brake Master Cylinder	7	Drag Link Repair Kit and Seals	11
Brake Parts	5, 6, 7, 8, 9, 11, 106	Drums (Brake)	3
Brake Shoes	5	—E—	
Bulbs	48	Electric Window Kit	128
Bumper (Front)	69	Emblems	28, 29, 55, 59, 60, 90
Bumper (Rear)	69	Emergency Brake Parts.....	9, 24, 77, 122
Bumper Brackets & Bolts	69	Emergency Brake Cable	9, 124
Bumpers (Axle)	9	Engine Gasket Sets	18, 118
—C—		Escutcheon Plates	85
Cab Corners (Front & Rear).....	1201, 102	Exhaust Manifold Parts	34
Cab to Frame Bolts	14	Exhaust Deflectors	15, 70
Cab to Frame Arm	14	Exhaust Headers	119
Cab to Frame Pads	14	Exhaust Pipes	15
Cab Trim Panel	90	—F—	
Cab Weatherstrip kits	78	Fan and Hub Parts	31
Cam Gear	20	Fan & Generator Belts	30
Cam Bearing	20	Fenders	52, 53, 57, 58, 62
Camshaft	20	Fender Alignment Rods	57
Carburetor (New)	34	Fender Bolt Kits ..	52, 53, 57, 58, 108, 109
Carburetor Rebuilding Kits	34	Fender Braces	53, 57, 58
Carburetor to Manifold Gaskets	34	Fender Extensions	52
Carpet	90	Fender (Inner)	52, 57, 62, 105
Choke Cable	37	Fender Parts	52, 53, 57, 58, 62, 105
Cigar Lighter Parts	49	Fender Seal	53, 57
Clutch and Brake Pedal Pads	8	Fender Welt	58
Clutch Parts	8, 9, 25, 26	Firewall	125
Clutch Pressure Plate	26	Firewall Covers (ABS)	74
Clutch Disk	26	Firewall Grommets	51
Clutch Retracting Spring	26	Floor Mats	77, 90
Coils	40	Floor Pans	103, 125
Condensor	40	Flywheel	20
Connecting Rods	20	"Fordomatic" Script	90
Connecting Rod Bearings	20	Frame Horn Covers	68
Cowl Lacing	54, 60	Front End Bolt Kit	57
Cowl Patch Panels	75	Fuel Blocks	120
Cowl Vent Gasket	75		
		Fuel Line	33, 120
		Fuel Pump	33
		Fuel Pump Stand	33
		Fuel Regulator	120
		Fuel System	31, 32, 33, 34, 117, 120
		Fuel Tank Adapter Ring	117
		Fuel Tank Sealer	32
		Fuse Panel	106
		—G—	
		Gas Cap	31, 127
		Gas Line	33, 120
		Gas Tank (Original)	33
		Gas Tank (Custom)	127
		Gas Tank Adapter Ring	117
		Gas Tank Sending Unit	32
		Gas Tank Straps	33
		Gaskets (Engine)	18, 118
		Gaskets (Head)	19, 118
		Gaskets (Manifold)	34, 118
		Gaskets (Oil Pan)	23
		Gauges	114, 115, 116, 117
		Gear Shift Boot	24, 77
		Gear Shift Insulator	25
		Gear Shift Knob	24
		Generator & Fan Belts	30
		Generator Parts	38
		Generator Cover (Stainless)	119
		Gift Certificates	123
		Glass Sets	76, 129
		Glass Setting Tape	82
		Glove Box and Parts	87
		Grille	27, 28
		Grille Bars	27
		Grille Emblems	28
		Grille Panels (Upper)	29
		Grille Stars	28
		Grille Teeth	28
		Grille Valance (Lower)	29, 61
		Grommets	32, 42, 51, 64, 65, 66, 74
		Gull Wings	28
		—H—	
		Hats	107
		Heads (High Compression)	118
		Headers	119
		Head Bolts	18
		Head Gasket	19, 118
		Headlight Dimmer Switch	42
		Headlight Door	41
		Headlight Parts	39, 41, 42, 50
		Headlight Socket & Wire	42
		Headlight Support Panel	29, 61
		Headlight Switch	39
		Headliner	88
		Heat/Cool System	126
		Heater Motor	72
		Heater Parts	72, 73
		Heater Switch	73
		Hinge Pins	90, 130
		Hoods	54, 59
		Hood Bumpers	54, 60
		Hood Emblems	55, 59, 60
		Hood Hinge	54, 59
		Hood Hinge Springs	54, 59
		Hood Latch	56, 60
		Hood Molding	55
		Hood Parts	54, 55, 56, 59, 60
		Horn Button	13
		Horn Parts	13
		Horn Relay	49
		Hub Bolt	3
		Hubcaps	3

Continued on Page 2

1948-56 FORD PICKUP INDEX

—I—				
Ignition Coil	40	Pickup Bed Panels	93, 94	
Ignition Coil Ballast Resistor	40	Pickup Bed Metal Strips	92	
Ignition Condensor	40	Pistons	19, 119	
Ignition Parts	39, 40, 41	Plug Wires	41	
Ignition Points	40	Points	40	
Ignition Rotor	40	Power Brake Kit	112	
Ignition Switch	39	Power Windows	128	
Ignition Wire Brackets and Grommets ..	41	—R—		
Ignition Wire Loom	106	Radiator (Walker)	121	
Inner Fender	105	Radiator Cap	27	
Intake Manifolds	118	Radiator Hose	30	
Intake Manifold Gaskets	22, 118	Radiator Overflow Tank	121	
Interior Trim Parts	89	Radiator Parts	27, 29, 30, 31, 21	
—K—			Radiator Support	
Key Blanks	39	Radiator Support Pads	27	
Kickdown Kit	124	Radio Antenna	71	
Kick Panels and Retainers	89	Radio	86	
King Pin Sets	10	Radio Hole Cover	87	
Knobs	24, 35, 36, 39, 49, 65	Radio Speaker Grille	87	
—L—			Rings (Piston)	
License Frame (Lighted)	47	Rings (Piston)	19, 119	
License Plate Bracket	47	Rocker Panels	77, 101, 102, 121	
License Plate Lamps	47, 120	Rocker Sills	90, 121	
Light (Jewel Turn Indicator)	51	Roll Pans	105	
Light Bulbs	48	Roof Skin (1956)	104	
Literature	131	Rotor	40	
Lug Nuts	3	Running Boards	63	
—M—			Running Board Step Plates	
Main Bearing Set	21	—S—		
Manifold Gaskets	22, 34, 118	Seat Belts	89	
Manuals	131	Seat Covers	88	
Master Cylinder	7	Sending Unit (Oil)	34	
Master Cylinder Adapter	7	Sending Unit (Temperature)	34	
Master Cylinder Cover Plate	7	Shirts (Tee's)	107	
Master Cylinder Parts	7	Shifter	125	
Meet Schedule	132	Shock Absorbers	70	
Mirrors	67, 68	Shop Manuals	131	
Molding (Hood)	55	Smithy Mufflers	15, 120	
Motor Mounts	18, 19, 110, 111	Solenoid	38	
Muffler	15, 120	Spark Plugs	41	
—N—			Spark Plug Wires	
Nut Covers (Chrome)	18	Speaker Trim	87	
—O—			Speedometer Cable	
Oil Filler Tube	23	Speedometer Parts	64	
Oil Filter	23	Spring Bushings	16, 17	
Oil Pan Gasket	23	Speedometer Parts	64	
Oil Pump	22	Spring Bushings	16, 17	
Oil Pump Parts	20, 23	Springs	16, 17, 113	
Oil Pump Pickup Tube	23	Spring Shackle Kits	16, 17	
Oil Pump Rebuilding Kits	22	Stake Pockets	93	
Oil Pump Screen	23	Starter (Flathead)	38	
Oil Sending Unit	34	Starter Button	38	
"Overdrive" Script	90	Starter Cover (Stainless)	119	
—P—			Starter Drive	
Panel Truck Parts	130	Starter Solenoid	38	
Park Lamp Assembly	42, 43	Steering Column Seals	11, 12	
Park Lamp Door	43	Steering Column (Tilt)	106	
Park Lamp Lens	43	Steering Column to Floor Cover Plate ..		
Park Lamp Lens Gasket	43	Steering Wheels	13	
Parking Brake Cable	9, 122	Steering Parts	11, 12, 13, 106	
Patch Panels	75, 101, 102, 103, 104, 105	Step Plates	62	
Patent Data Plates	74	Stop Light Switch	7, 45	
Pedal Pads	8	Striker Plate	83	
Pickup Beds	91, 100	Sun Visors	75	
Pickup Bed Crossmembers	93	Sun Visor Bracket	75	
Pickup Bed Floor	96, 97	Suspension Kits	113	
—Q—			Swap Meet Schedule	
—R—			—T—	
—S—			Tail Lamp Assembly	44, 45
—T—			Tail Lamp Brackets	44, 45
—U—			Tail Lamp Lens	45, 46
—V—			Tail Lamp Lens Gasket	46
—W—			Tail Lamp Wire Shield	47
—X—			Tail Lamp Socket	46
—Y—			Tail Pipe	15
—Z—			Tailgates	94
—AA—			Tailgate Letters (FORD)	94
—AB—			Tailgate Latches	99
—AC—			Tailgate Parts	93, 94, 95
—AD—			Tappets (Valve)	21
—AE—			Temperature Sending Unit	34
—AF—			Thermostat & Gasket	31
—AG—			Throttle Cable	37, 123
—AH—			Throttle Linkage	124
—AI—			Throwout Bearing	26
—AJ—			Tie Rod and Ends	10
—AK—			Tilt Front End Assembly	56, 62
—AL—			Tilt Hood	107
—AM—			Timing Gear	20
—AN—			Transmission Cover	103
—AO—			Transmission Gasket Set	24
—AP—			Transmission Mounts	110, 111
—AQ—			Transmission Parts	24, 25, 103, 124, 125
—AR—			Transmission Shifter	125
—AS—			Tune-Up Kit	40
—AT—			Turn Lights (Amber)	120
—AU—			Turn Signal Indicator Light	47
—AV—			Turn Signal Switch	47
—AW—			Universal Joint	23
—AX—			Vacuum Advance	40
—AY—			Valve	21
—AZ—			Valve Guide	21
—BA—			Valve Springs	22
—BB—			Valve Tappets	21
—BC—			Vent Window Frame Assemblies	81
—BD—			Vent Window Assemblies (Complete) ..	80
—BE—			Vent Window Handles	81
—BF—			Vent Window Rubber	81
—BG—			Vent Window Seal	81
—BH—			Vin Number Plate	74
—BI—			Voltage Reducer	49
—BJ—			Voltage Regulator	38
—BK—			Walker Radiators	121
—BL—			Water Outlet & Gasket	31, 119
—BM—			Water Pump	30
—BN—			Weatherstrip Kits (Cab)	78
—BO—			Wheel Bearings	4
—BP—			Wheel Cylinder (Front)	5
—BQ—			Wheel Cylinder (Rear)	6
—BR—			Wheel Cylinder Rebuilding Kit	5, 6
—BS—			Wheel Seals	4
—BT—			Wheel Trim Rings	3, 71
—BU—			Window Anti-Rattler	79
—BV—			Window Crank Handle	85
—BW—			Window Glass Sets	76, 129
—BX—			Window Lift Channels	82
—BY—			Window Parts	81, 82, 128
—BZ—			Window Regulators	82
—CA—			Window Rubber Molding	76
—CB—			Window Shades	70
—CC—			Windshield Rubber	76
—CD—			Windshield Wiper Motor	65
—CE—			Windshield Wiper Parts	65, 66
—CF—			Wiper Arms and Blades	66
—CG—			Wiper Pivot Assembly	66
—CH—			Wiper Pivot Repair Kit	66
—CI—			Wiper Shaft Bezel	66
—CJ—			Wire Loom	51
—CK—			Wire Connectors	51
—CL—			Wiring	50, 51, 106
—CM—			Wiring Clamps	51
—CN—			Wood Floor Kits	96



HUBCAPS

1948-56, F-1, Stainless Steel, unpainted, original style		
6A-1130-SS	each	30.00
1946 Passenger, Stainless Steel		
51A-1130-SS	each	30.00
1948-56, F-250, 3/4 ton Pickup, Stainless Steel		
2J-1130-A	each	50.00

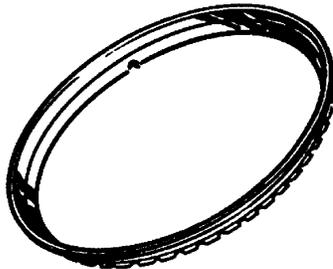

BEAUTY RINGS

15 inch, 4 rib pattern		
O1A-18303-15	each	29.00
16 inch, 4 rib pattern		
O1A-18303-16	each	29.00
14 inch, smooth face		
6A-18303-14	each	29.00
15 inch, smooth face		
6A-18303-15	each	29.00
16 inch, smooth face		
6A-18303-16	each	29.00
15 inch, smooth convex		
8A-18303-15	each	29.00

AXLE PARTS



1012

LUG NUTS

1948-56, F-1		
B-1012	each	.75



1013

LUG NUTS "CUPPED" WASHER

1948-56, F-1, Solves that worn wheel hole problem		
B-1013	each	.75



1107

HUB BOLT STUD

1948-56, F-1, Front and Rear		
8A-1107-A	each	2.50

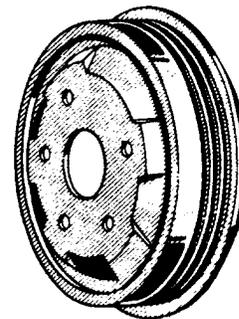

1125

FRONT DRUM

1948-52, F-1		
8C-1125	each	98.00
1953-56, F-1		
A8TZ-1125	each	98.00

REAR DRUM

1948-56, F-1, 11"		
A8TZ-1126	each	98.00



FRONT AXLE PARTS

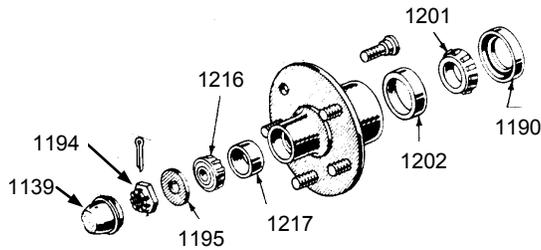

FRONT WHEEL DUST CAP

1948-56, Push-on type, 1-15/16" I.D.
51A-1139 each 6.00

FRONT WHEEL GREASE SEAL

1948-56, F-1, F-2, F-3
O1Y-1190-A each 5.50

SPINDLE NUT

1948-56, F-1, F-100
68-1194 each 5.00

FRONT HUB OUTER BEARING WASHER

1948-56, F-1, F-2
B-1195 each 3.00

FRONT WHEEL INNER BEARING

1948-56, F-1, F-2, F-3
O1Y-1201 each 20.00

FRONT WHEEL INNER BEARING RACE

1948-56, F-1, F-2, F-3
O1Y-1202 each 8.00

FRONT WHEEL OUTER BEARING

1948-56, F-1, F-2, F-3
8A-1216 each 16.00

FRONT WHEEL OUTER BEARING RACE

1948-56, F-1, F-2, F-3
8A-1217 each 7.00

REAR AXLE PARTS

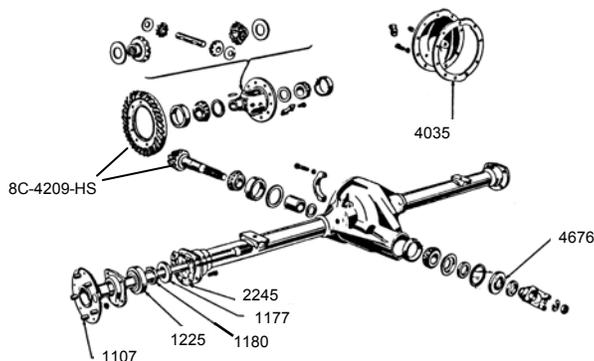

DIFFERENTIAL GASKET

1948-50, F-1, F-100
8M-4035 each 6.00
1951-56, F-1, F-100
1M-4035 each 6.00

REAR AXLE SEAL

1948-56, F-1
OM-1177-A each 5.50

RING AND PINION GEAR SET

1948-50, F-1, 3:54:1
8C-4209-HS set 399.00

PINION SEAL

1948-56, F-1, F-100
8M-4676-A each 8.00

PINION BEARING & RACE

1948-56, F-1, F-100, Front Pinion Bearing
8M-4621 each 35.00
1948-56, F-1, F-100, Front Pinion Bearing Race
8A-4616 each 19.00
1948-56, F-1, F-100, Rear Pinion Bearing
8M-4630 each 40.00
1948-56, F-1, F-100, Rear Pinion Bearing Race
8A-4628 each 25.00

BACKING PLATE GASKET

1948-56, F-1, Bearing Retainer to Backing Plate
8M-2245 each 3.00
1948-56, F-1, Axle Housing to Backing Plate
8M-2245-A each 3.00

REAR AXLE BEARING

1948-56, F-1, 3.3M Axle
8M-1225-A each 30.00

REAR WHEEL BEARING RETAINER

1948-56, F-1
8M-1180 each 12.00

BRAKES

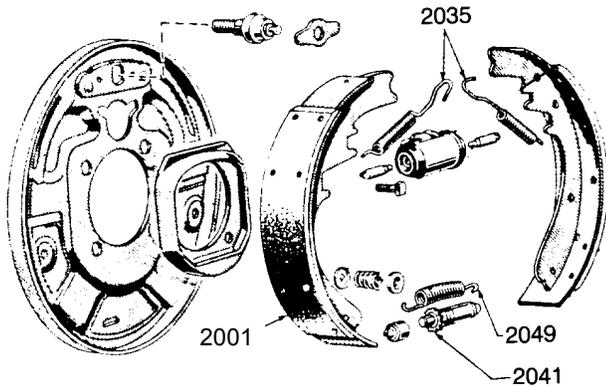

FRONT BRAKE SHOE & LINING SET

1948-56, F-1, Set of 4 pcs.
 8C-2001-F set 49.00
 1948-52, F-200-300, Set of 4 pcs.
 51A-2001-S set 60.00

REAR BRAKE SHOE & LINING SET

1948-56, F-1, Set of 4 pcs.
 8C-2200-R set 49.00

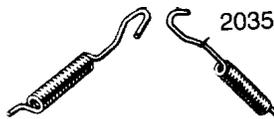

BRAKE RETRACTING SPRING

1948-56, F-1, Needs 2 per wheel
 B5A-2035-A each 4.50
 1948-51, F-2, F-3
 91A-2035 each 3.00

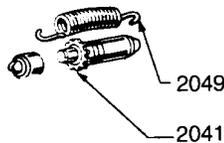

BRAKE ADJUSTER "STAR WHEEL"

1948-56, F-1
 B7A-2041-S each 10.00

BRAKE ADJUSTING SCREW SPRING

1948-56, F-1
 H-2049 each 6.00

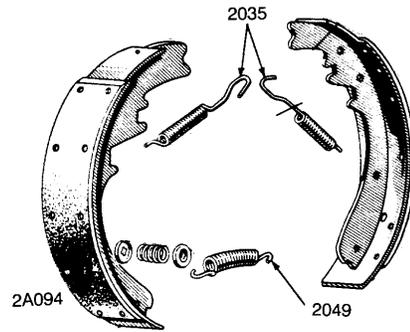

BRAKE SHOE HOLD DOWN KIT

1948-56, F-100, Includes all of the hold down parts, adjusting screw springs and heavy duty return springs needed to do 2 complete wheels
 B5AZ-2A094 2 wheel kit 25.00



NEW FRONT WHEEL BRAKE CYLINDER

1948-56, F-1, Right Hand
 8C-2061 each 39.00
 1948-56, F-1, Left Hand
 8C-2062 each 39.00
 1948-52, F-250, Right Hand, 1-3/8" X 1"
 21A-2061 each 35.00
 1948-52, F-250, Left Hand, 1-3/8" X 1"
 21A-2062 each 35.00
 1951-56, F-250, Right Hand, 1-1/8" Dia.
 1D-2061-Reach 40.00



FRONT WHEEL CYLINDER REBUILDING KIT

1948-56, F-1
 A8C-2221 kit 10.00
 1948-52, F-2
 21A-2221 kit 10.00



PARK BRAKE LEVER LOCK CLIP

1948-56, F-1, Needs 2 per truck
 91A-2106 each 1.00

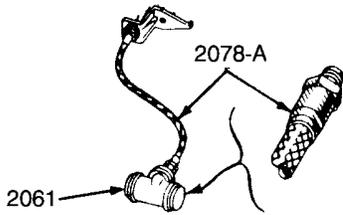

FRONT BRAKE HOSE

1948-52, F-1
 8C-2079 each 18.00
 1953-56, F-1
 TAAA-2078-A each 20.00



2261

NEW REAR WHEEL CYLINDER

1948-54, F-1, Right Hand
 8M-2261 each 38.00
 1948-54, F-1, Left Hand
 8M-2262 each 38.00
 1948-52, F-2, Right Hand
 21A-2061 each 35.00
 1948-52, F-2, Left Hand
 21A-2062 each 35.00
 1951-56, F-2, Right Hand, 1-1/8" Dia.
 1D-2261 each 35.00
 1951-56, F-2, Left Hand, 1-1/8" Dia.
 1D-2262 each 35.00
 1955-56, F-1, Right Hand
 8A-2261 each 38.00
 1955-56, F-1, Left Hand
 8A-2262 each 38.00



REAR WHEEL CYLINDER REBUILDING KIT

1948-54, F-1
 A8C-2128 kit 8.00
 1955-56, F-1
 8A-2128 kit 8.00



REAR BRAKE HOSE

1948-56, F-1
 8A-2078 each 17.50
 1948-56, F-2
 O1T-2078 each 18.50

BRAKE ADJUSTING HOLE COVER

1948-56, F-1, Rubber
 8A-2092 each 1.00

STEEL BRAKE LINE KITS

All Brake Lines include fittings

1948-52, F-1, Pre-Bent, Includes:
 1—Master Cylinder to Rear Brake Hose—74"
 1—Left Front—43-1/2"
 1—Right Front—69-1/2"
 1—Left Rear—21-1/4"
 1—Right Rear—40-5/8"
 7C-2269-K kit 120.00



NEW MASTER CYLINDER

1948-52, F-1 91A-2140	each	85.00
1948-52, F-2 91T-2140-A	each	95.00
1953-56, F-1 B3C-2140-A	each	90.00
1953-56, F-2 B3T-2140-A	each	95.00



MASTER CYLINDER REBUILDING KIT

1948-56, F-1 91A-2004	kit	16.00
1948-56, F-250 91T-2004	kit	20.00

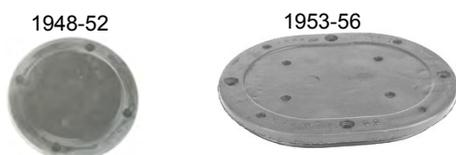

MASTER CYLINDER COVER PLATE

1948-52, Rubber molded over steel as original 91A-7011136	each	8.00
1953-56, Rubber molded over steel as original BAAA-8111136	each	15.00



STOP LIGHT SWITCH

1939-56, Screws in Master Cylinder 11A-13480	each	6.00
---	------	------

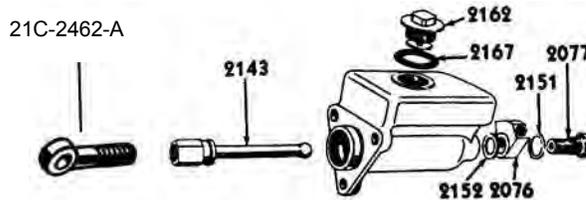

MASTER CYLINDER PUSH ROD

1948-56, F-1 91A-2143	each	12.00
--------------------------------	------	-------

BRAKE ARM TO MASTER CYL. EYE BOLT

1942-52, 3/8"-24X3 1/8" Long, Attaches brake arm to Master Cylinder Push Rod 21C-2462-A	each	20.00
---	------	-------

MASTER CYLINDER FILLER CAP

1948-52, F-1 91A-2162	each	15.00
1953-56, F-1 AB-2162	each	15.00

MASTER CYLINDER FILLER CAP GASKET

1948-52, F-1 91A-2167	each	2.00
1953-56, F-1 8M-2167	each	2.00

MASTER CYLINDER OUTLET FITTING

1948-56 8C-2076	each	15.00
--------------------------	------	-------

MASTER CYLINDER BOLT

1948-56 91A-2077-A	each	8.00
-----------------------------	------	------

MASTER CYLINDER OUTLET GASKET

1948-56, Copper, between bolt and outlet fitting 91A-2151	each	1.00
1948-56, Copper, between outlet fitting and Master Cylinder 91A-2152	each	1.00



MASTER CYLINDER ADAPTER

1948-52, This kit converts the original single reservoir Master Cylinder to a dual reservoir system , includes Adapter Plate and Master Cylinder

- 7C-2140-KIT kit 175.00
- 1948-52, As Above, Adapter Plate only
- 2140-ADT each 80.00

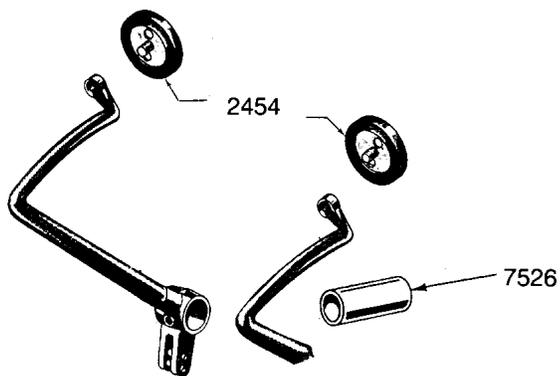

BRAKE PEDAL BUSHING

- 1948-52, F-1, Brake Pedal Bushing
- B-7526 each 5.50
- 1953-56, F-1, Clutch and Brake Pedal Bracket to Shaft Bushing, need 2
- 7EQ-5344-A each 4.50



There's a good chance we have your parts in stock



BRAKE & CLUTCH PEDAL PAD

1948-56, Pickup, Made of polished stainless steel with a rubber inserted pad

- 40-2454-SSB each 30.00



CLUTCH & BRAKE PEDAL PADS

1948-56, F-1, F-2, F-3, Round Style, 3-1/8" diameter

- 11A-2454 each 9.00
- 1948-56, F-500-900, and 1953-56, F-350, Round Style, 3-1/2" dia.
- 7RT-2454 each 10.00



01T-2472



TAAA-2472-AS

BRAKE PEDAL RETURN SPRING

- 1948-52, F-1
- O1T-2472 each 6.00
- 1953-56, F-1
- TAAA-2472-AS each 4.00



CLUTCH & BRAKE PEDAL ARM BUMPERS

1948-56, F-1, Goes in hole under floorboard
 7C-2473 pair 3.50

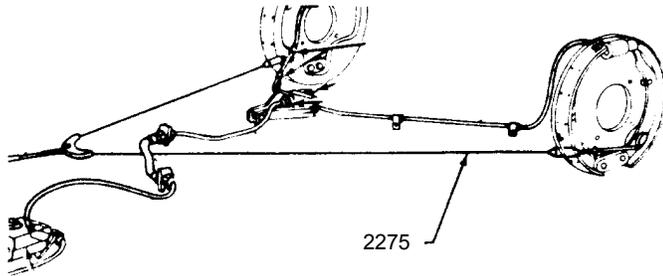

REAR PARKING BRAKE CABLE & HOUSING ASSEMBLY

1948-52, F-1, Also called Emergency Brake Cable, need 2
 7C-2275-A each 45.00
 1953-56, F-1, One Cable does both back wheels
 FAAA-2275-A each 50.00



PARK BRAKE LEVER LOCK CLIP

1948-56, F-1, Needs 2 per truck
 91A-2106 each 1.00

FREE SHIPPING

Pre-paid orders over \$1,000 are shipped free by UPS ground within the continental US. Free shipping does not apply to back orders, truck freight, UPS oversize (exceeding 48") or overweight (exceeding 70 lbs.).

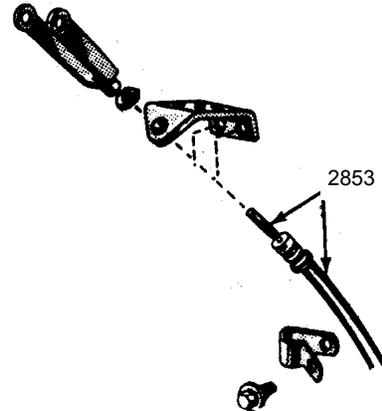

FRONT PARKING BRAKE CABLE & HOUSING ASSEMBLY

1948-52, F-1, Handle to under pickup
 2C-2853-A each 55.00
 1953-56, F-1, 110" wheel base
 TAAA-2853-A each 70.00



FRONT AXLE BUMPERS

1948-56, F-1
 7RC-3020 each 8.00



REAR AXLE BUMPERS

1948-56, F-1
 11A-3020 each 8.00



KING PIN SETS

1948-52, F-1, F-2, F-3, One set does both sides		
21A-3111	set	50.00
1953-56, F-1, F-2		
B3C-3111-A	set	60.00



TIE ROD ENDS

1948-56, F-1, F-2, Right Hand Thread		
11A-3289	each	16.00
1948-56, F-1, F-2, Left Hand Thread		
11A-3290	each	16.00

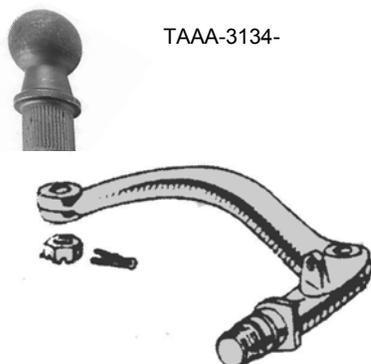

TAAA-3134-

BALL STUD FOR LEFT HAND SPINDLE ARM

1948-56, F-1		
TAAA-3134-BSX	each	20.00



TIE ROD END SEAL SET

1948-56, F-1, F-2		
48-3332-S	set of 4	6.00



TIE RODS

1948-52, F-1, F-2, F-3		
21A-3283	each	60.00
1953-56, F-1, F-2		
TAAA-3281-A	each	75.00

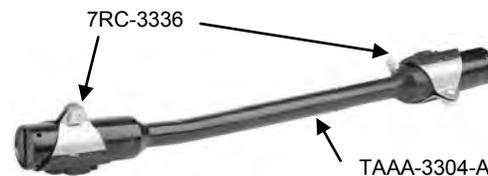

DRAG LINK ASSEMBLY
Includes Internal Parts

1948-56, F-1, F-2, Fits Steering Arm to Idler Arm, Rubber Covers not included		
TAAA-3304-A	each	75.00

DRAG LINK RUBBER COVER

1948-56, Need two		
7RC-3336	each	7.50



DRAG LINK END REPAIR KIT

1948-56, F-1, F-2, Includes all internal parts in ends of drag link. Need 2 kits
 A8TZ-3A533-A kit 15.00

7C-3513



BAAA-3513



STEERING COLUMN, CLUTCH & BRAKE ARM TO FLOOR SEALS

1948-52, Goes under metal plate at floor for column shift
 7C-3513 each 6.00
 1948-52, For floor shift
 7C-3513-A each 6.00
 1953-56, For column shift
 BAAA-3513 kit 8.00
 1953-56, For floor shift
 BAAA-3513-A kit 8.00



15



7C-8112150/1

STEERING COLUMN TO FLOOR MAT SEAL

1948-52, Goes on top of mat, comes with clips, for column shift
 7C-3515 kit 11.00
 1948-52, For floor shift
 7C-3515-Akit 11.00
 1948-52, Steering Column to floor cover plates, pair
 7C-8112150/1 pair 35.00

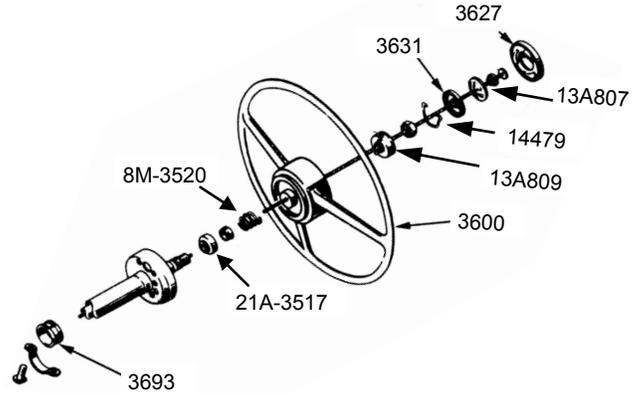

STEERING COLUMN TO BRACKET "ANTI-SQUEAK PAD"

1948-52, F-1
 7C-3679-S each 5.00
 1953-56, F-1
 TAAA-3693 each 3.00

STEERING WHEEL

1948-52
 8T-3600 each 199.00
 1953-55
 TAAA-3600 each 199.00
 1956
 B6C-3600 each 199.00

UPPER STEERING COLUMN BUSHING

1948-56, F-1
 51A-3517 each 5.00

UPPER STEERING COLUMN BEARING

1948-56,
 21A-3517 each 8.00

UPPER STEERING COLUMN BEARING SPRING

1949-56
 8M-3520 each 2.00

STEERING WHEEL NUT

1948-56, F100-F600
 359553-S each 2.50



STEERING BOX PARTS

STEERING SHAFT & WORM ASSEMBLY

1948-52, F-1, F-2, F-3		
7HC-3524	each	180.00
1953-55, F-1, F-2		
TAAA-3524-A	each	180.00
1956, F-1, F-2		
B6C-3524-A	each	180.00

WORM GEAR ONLY

1948-52, F-1, F-2, No shaft, must use old shaft		
7HC-3524-X	each	75.00
1953-56, F-1, F-2, No shaft, must use old shaft		
B7C-3524-X	each	75.00

STEERING BOX LOWER BEARING RACE

1948-56, F-1, F-2		
8A-3553	each	22.00

STEERING BOX UPPER BEARING RACE

1948-56, F-1, F-2		
B-3552	each	12.00

STEERING BOX WORM ROLLER BEARING

1948-60, F-1, Takes 2		
68-3571	each	13.00

STEERING BOX GASKET SET

1948-56, F-1, F-2		
7C-3581-S	set	10.00

STEERING SHAFT FELT SHIELD

1948-56, F-1, F-2		
21C-3738-A	each	3.00

STEERING SECTOR SHAFT

1948-52, F-1, F-2, F-3		
7RC-3575	each	260.00

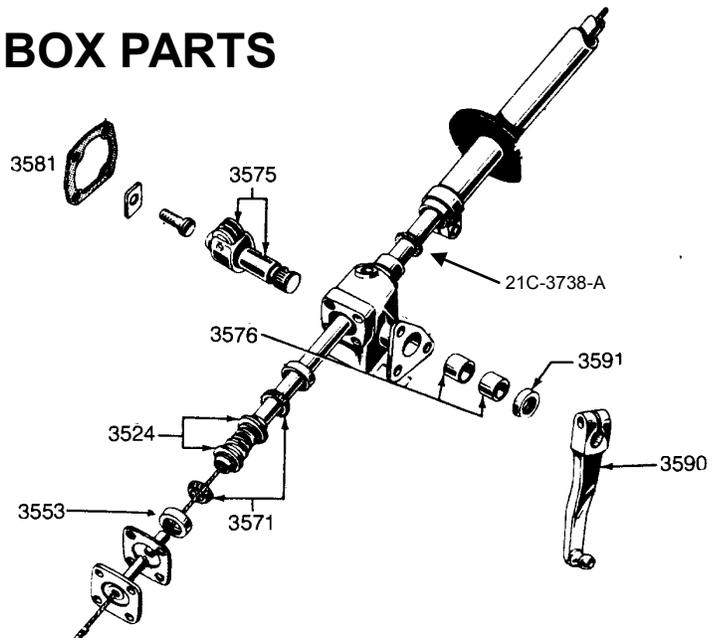

STEERING SECTOR ROLLER AND PIN KIT

1948-52, F-100, Must use old shaft		
7C-3575-R	each	78.00
1953-56, F-100, Must use old shaft		
B6C-3575-R	each	75.00

STEERING SECTOR SHAFT BUSHING

1948-52, F-1, Takes 2		
78-3576-A	each	4.00
1953-56, F-1		
81T-3576-A	each	6.00

STEERING PITMAN ARM

1948-52, F-1, F-2, F-3		
8C-3590	each	75.00
1953-56, F-1, F-2		
TAAA-3590-A	each	90.00

STEERING BOX OIL SEAL

1948-52, F-1, F-2, F-3		
8A-3591	each	4.50
1953-56, F-100, F-250, F-350		
8M-3591	each	4.50

7HC-3627-C



BAAA-3627-A



B4C-3627-SS



BAAA-3627-SS

HORN BUTTON

1948-52, Black Plastic		
7HC-3627-C	each	18.00
1953, 50th Anniversary Horn Button		
BAAA-3627-A	each	75.00
1953, 50th Anniversary Horn Button, Plastic Only		
BAAA-3627-ANV	each	50.00
1954-56, 5-Star Cab Horn Button, Polished Stainless		
B4C-3627-SS	each	45.00
1954-56, 5-Star Cab Horn Button, w/Black Center		
B4C-3627-A	each	45.00
1953-56, Painted White		
BAAA-3627	each	50.00
1953-56, Polished Stainless		
BAAA-3627-SS	each	50.00
1956, Horn Button with Red Center		
B6C-3627-A	each	50.00

HORN PARTS

1948-56, Horn Button Diaphragm Spring		
A7TZ-13A807-A	each	6.00
1948-52, Horn Button Index Plate		
7C-13A809-A	each	10.00
1953-56, Horn Button Index Plate		
BAAA-13A809-A	each	10.00
1948-56, Horn Button Index Spring		
7RC-14479	each	3.00
1948-56, Horn Button Contact Plate		
7RC-3631	each	6.00
1948-56, Horn Contact Wire. Wire that runs from Horn Button down through steering column, includes rivet and washer		
FAB-14308-A	each	15.00



HORN BUTTON KIT

1948-52, Contains contact plate, spring, index plate, horn wire, and index plate clip		
7C-13809-KIT	kit	32.00
1953-56, As Above		
BAAA-13809-KIT	kit	32.00



STEERING WHEEL

1948-52		
8T-3600	each	199.00



1953-55		
TAAA-3600	each	199.00



1956		
B6C-3600	each	199.00



BAAA-5369-S

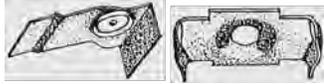

BAAA-5372-S

LOWER BODY MOUNT

1953-56, Lower Body Mount with upper bushing cup installed. This goes under front post body mount and on top of upper cab to frame pad.

BAAA-5369-S pair 25.00

LOWER BUSHING RETAINER

1953-56, Lower Bushing Retainer. This goes under the upper cab to frame pad

BAAA-5372-S pair 10.00

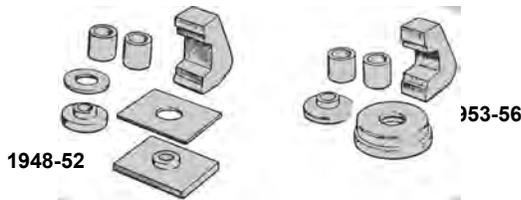

1948-52

1953-56

CAB TO FRAME PAD & BUSHING KIT

1948-52, 14 pieces
7C-5400-S kit 25.00

CAB TO FRAME BOLT KIT

1948-52, Bolts that mount cab to frame
7C-5404-KIT kit 25.00

1948-52, As Above, Stainless Steel
6-0329 kit 30.00

1953-56, Bolts that mount cab to frame
BAAA-5404 kit 20.00

1953-56, As Above, Stainless Steel
6-0275 kit 39.00

RUBBER PLUG FOR REAR OF CAB

1953-56, 1-1/2" hole plug
352285-S each 2.00



CAB TO FRAME ARM

1948-56, Forged type, complete with bushings
7C-5352 each 25.00



CAB TO FRAME BRACKET

1948-56,
7C-5388 each 24.00

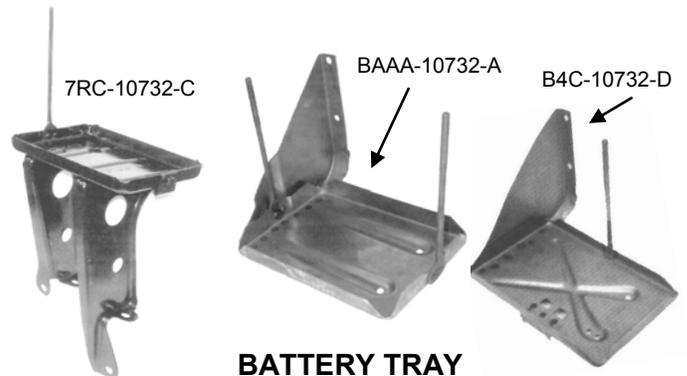

BATTERY TRAY

1948-52, V-8, 239 & 337
7RC-10732-C each 100.00

1953
BAAA-10732-A each 65.00

1954-55
B4C-10732-D each 65.00

1956, Battery Tray
B6C-10732-A each 70.00

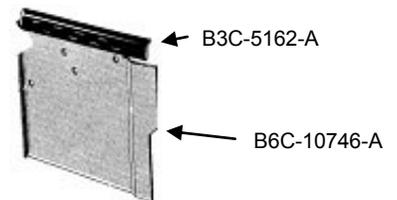

BATTERY DEFLECTOR SHIELD

1953-56, Without rubber
B6C-10746-A each 18.00

1953-56, Battery Deflector Shield Rubber
B3C-5162-A each 4.00

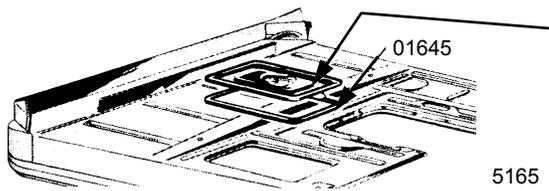

BATTERY HOLD DOWN COVER

1953-55, with handle BAAA-5165	each	49.00
1956, with handle B6C-5165	each	49.00

BATTERY HOLD DOWN COVER SEAL

1953-55, BAAA-8101645-B	each	12.00
1956, B6C-8101645-B	each	12.00



BATTERY HOLD DOWN PARTS

1948-52, Battery Hold Down Frame 40-5165	each	10.00
1948-52, Battery Hold Down Bolt 11A-5175	each	4.00
1948-52, Battery Hold Down Nut & Washer Kit 11A-5179-S	kit	4.00



EXHAUST DEFLECTORS

Ford Script 51A-18259-A	each	18.00
V-8 Exhaust Deflector 51A-18259-B	each	18.00



INLET EXHAUST PIPE

1948-52, F-1, F-3, 239 V-8 7RC-5246-C	each	70.00
--	------	-------

TAIL PIPE

1948-52, F-1, 6 and 8 cyl. 8C-5255-B	each	62.00
1953, F-1 TAAA-5255	each	52.00



CROSSOVER PIPE

1948-53, F-1 through F-6, V-8 59C-5267	each	32.00
1954, F-1 through F-6, V-8 EBU-5267-B	each	55.00
1955-56, F-1 through F-6, V-8 B5A-5267	each	55.00



MUFFLER

1948-53, F-1 7HC-5230	Out of Production
--------------------------------	-------------------



A true 50's sound that is resonated through Smithy's legendary 22" mufflers. 3 1/2" diameter, 2" inlet/outlet
SM-5120 pair 80.00

FRONT SPRING PARTS

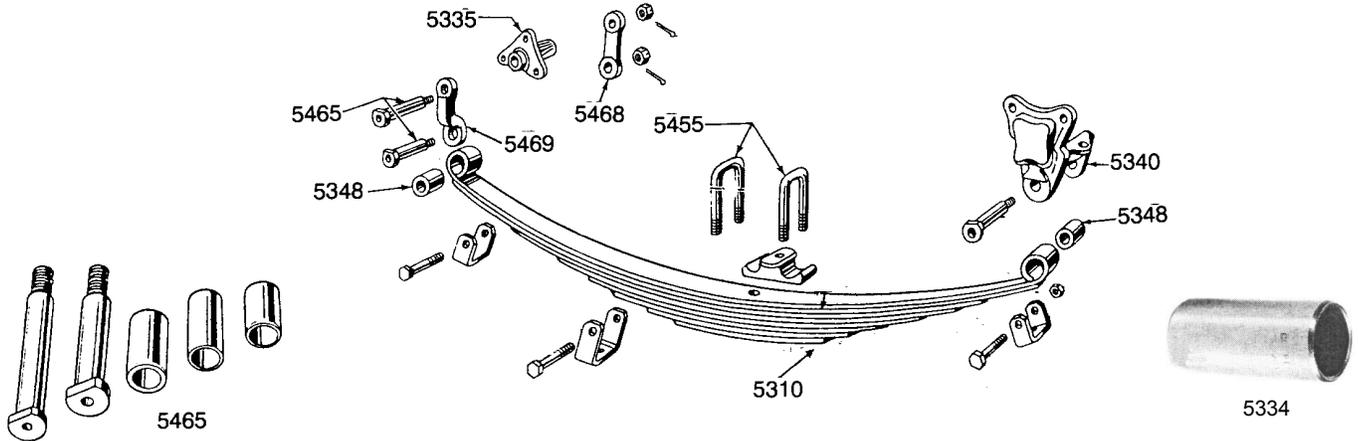

FRONT SPRING

1948-52, F-1		
21C-5310-B	each	Out of Production
1953-56, F-1, 8 Leaf		
TAAA-5310-A	each	Out of Production

FRONT SPRING SHACKLE KITS

1948-52, F-1, F-2, F-3, For both springs, consists of (4) 21C-5465 pins, (2) 7RC-5465 pins, (4) 21C-5348 bushings and (4) 7RC-5334 bushings		
7C-5300-S	kit	60.00
1953-56, F-1, F-2, For both springs, consists of (4) 21C-5348-A bushings, (2) 21C-5344-A bushings and (6) 21C-5465 pins		
BAAA-5300-S	kit	50.00

FRONT HANGER BRACKET

1953-56, F-100, F-250		
TAAA-5335	each	Discontinued

REAR HANGER BRACKET

1948-52, F-1, F-2, F-3, For Front Spring		
7RC-5340	each	30.00
1953-56, F-1, F-2		
B5C-5340	each	30.00

FRONT BRACKET BUSHING

1948-52, F-1, 4 required		
7RC-5334	each	5.00
1953-56, F-100, 4 required		
21C-5344-A	each	6.00

FRONT SPRING BUSHING

1948-56, F-1, 4 required		
21C-5348	each	6.00

FRONT SPRING "U" BOLTS

1948-56, F-1		
B3C-5455-A	each	8.00

SHACKLE BOLT

1948-56, F-1, F-2, F-3, 3-1/4" long. Also called Front Spring Shackle Stud		
21C-5465	each	6.00
1948-52, F-1, F-2, F-3, 4" long		
7RC-5465	each	15.00

FRONT SPRING SHACKLE BAR

1948-56, F-1, F-2, F-3, Inner		
7RC-5468	each	8.00
1948-52, F-1, F-2, F-3, Outer		
7RC-5469	each	8.00
1953-56, F-1, F-2, Outer		
B5C-5469	each	8.00

REAR SPRING PARTS

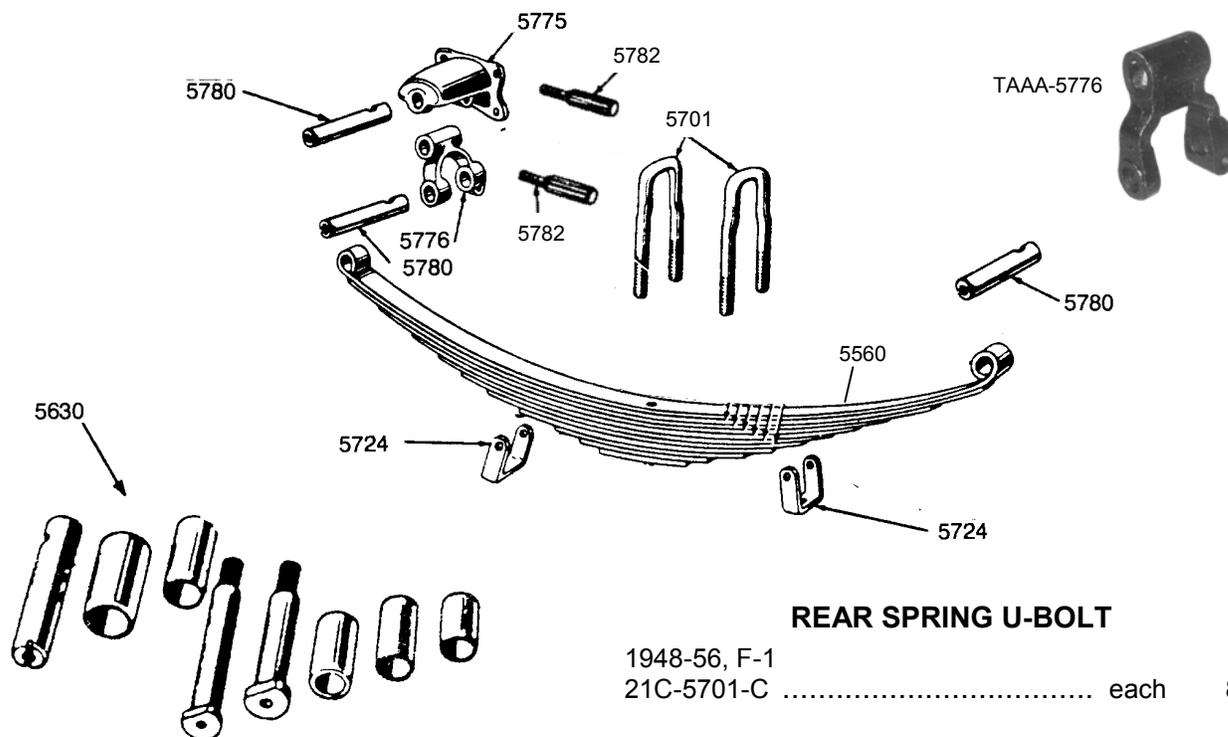

REAR SPRINGS

1948-52, F-1		
21C-5560	each	Out of Production
1953-54, F-1		
TAAA-5560	each	Out of Production
1955-56, F-1		
B5C-5560	each	Out of Production

REAR SPRING SHACKLE KIT

1948-56, F-1, Consists of (6) 21C-5780 pins, (6) 82Y-5782 pins, (4) 21C-5781-A bushings and (2) 21C-5791-A bushings. Does both springs		
7C-5630-S	kit	60.00

REAR SPRING SHACKLE PIN

1948-56, F-1, 3-1/2", Requires 6		
21C-5780	each	6.00

REAR SPRING MAIN LEAF BUSHING

1948-56, F-1, Requires 4		
21C-5781-A	each	8.00

REAR SPRING U-BOLT

1948-56, F-1		
21C-5701-C	each	8.00

REAR SPRING SHACKLE BRACKET TO FRAME

1948-52, F-1, Front and Rear		
21C-5775	each	40.00
1953-56, F-1, Front		
TAAA-5785	each	35.00
1953-56, F-1, Rear		
TAAA-5775	each	40.00

REAR SPRING HANGER BRACKETS

1948-52, F-1		
21C-5776	each	40.00
1953-56, F-1		
TAAA-5776	each	40.00

REAR SPRING RETAINING PIN

1948-56, F-1, F-2, F-3		
82Y-5782	each	2.50

REAR SPRING SHACKLE HANGER BUSHING

1948-56, F-1, Requires 2		
21C-5791-A	each	6.00

ENGINE

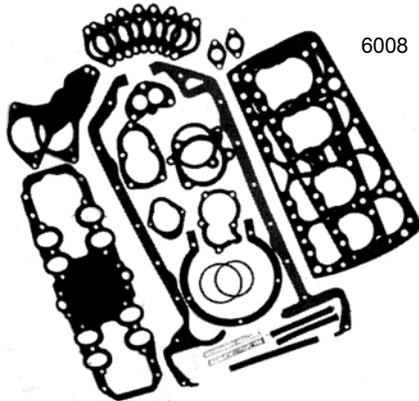

ENGINE GASKET SETS

1948-53, V-8, With Composite Head Gasket 8BA-6008-SA	set	90.00
1948-53, V-8, With Copper Head Gasket 8BA-6008-CC	set	120.00
1948-51, 6 cyl., 226 7HA-6008	set	140.00
1952-56, 6 cyl., 215, 223 EBP-6008	set	120.00
1954-55, V-8, 239, Overhead Valve EBU-6008	set	160.00
1955-56, V-8, 272, 292, 312 B7AZ-6008-F	set	120.00



CYLINDER HEAD NUT COVERS

1948-53, Flat Head, Chrome Plated, set of 50, 11/16" CNC-6062-AS	set	30.00
---	-----	-------

INTAKE BOLT HEAD COVERS

1948-53, Flat Head, Chrome Plated, set of 20, 9/16" CNC-6063-S	set	12.00
---	-----	-------



FRONT MOTOR MOUNTS

1948-51, F-1, F-2, F-3, 6 and 8 cyl., includes nut, bolt and bushings, requires 2 78-6038-S	kit	16.00
1952, F-1, F-6, Front Upper Bushing only 8L-6038-B	each	15.00
1952, F-1, F-2, F-3, Front Lower Bushing only 8L-6039-B	each	10.00
1953-56, F-1, 6 and 8 cyl., Front Upper Bushing only B5S-6038-A	each	20.00
1953-56, F-1, F-6, 6 and 8 cyl., Front Lower Bushing only TAAA-6039	each	6.00



CYLINDER HEAD BOLTS

1948-53, 1.94" long, V-8, 20 per engine 8BA-6065	each	2.25
1948-53, 2.26" long, V-8, 28 per engine 8BA-6066	each	2.25

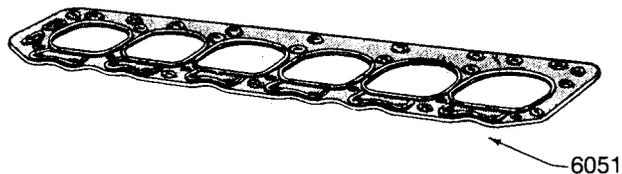

HEAD GASKETS

1948-51, F-1, 226, 6 cyl.		
7HA-6051	each	55.00
1948-53, F-1, V-8, Right Hand		
8BA-6051	each	39.00
1948-53, F-1, V-8, Right Hand, Copper		
8BA-6051-C	each	50.00
1948-53, F-1, V-8, Left Hand		
8BA-6083	each	39.00
1948-53, F-1, V-8, Left Hand, Copper		
8BA-6083-C	each	50.00

BIG BORE HEAD GASKETS

1949-53, Right Hand, Copper		
8BA-6051-BB	each	50.00
1949-53, Left Hand, Copper		
8BA-6083-BB	each	50.00

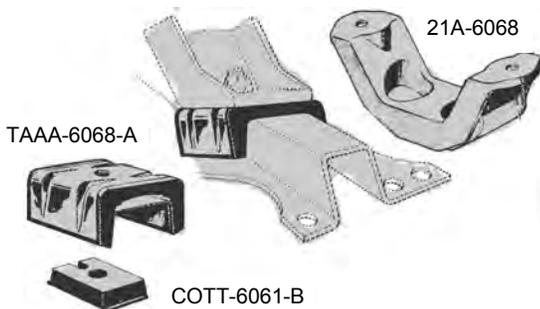

REAR MOTOR MOUNTS

1948-52, F-1, 6 and 8 cyl.		
21A-6068	each	30.00
1953-56, F-1, 6 and 8 cyl., Upper, 2 needed		
TAAA-6068-A	each	15.00
1953-56, F-1, 6 and 8 cyl., Lower, 2 needed		
COTT-6061-B	each	10.00

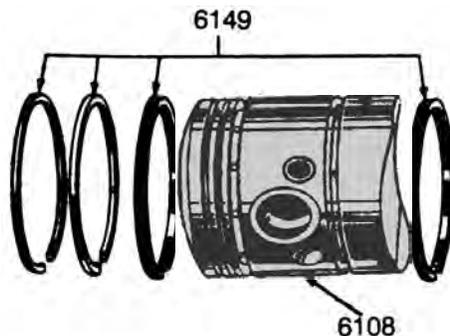

**PISTONS
Complete Set**

1948-53, V-8		
8BA-6108-STD	set	199.00
8BA-6108-020	set	199.00
8BA-6108-030	set	199.00
8BA-6108-040	set	199.00
8BA-6108-060	set	199.00

**PISTONS RINGS
Complete Set**

1948-53, V-8		
8BA-6149-STD	set	85.00
8BA-6149-020	set	85.00
8BA-6149-030	set	85.00
8BA-6149-040	set	85.00
8BA-6149-060	set	85.00

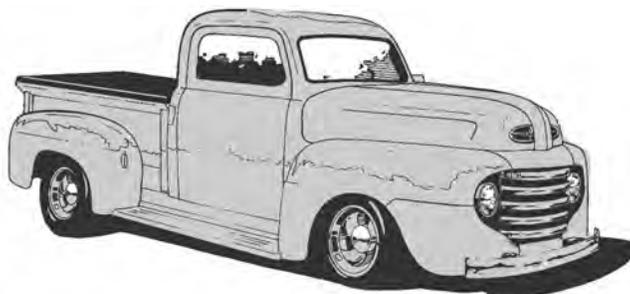

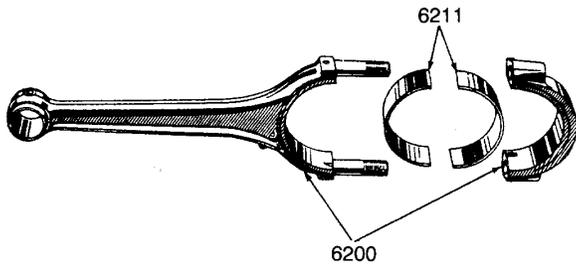

CONNECTING RODS

1949-50, All, V-8
 8BA-6200 each Discontinued

CONNECTING ROD BEARINGS

1949-53, V-8. 239. 256. Complete Engine Set
 OBA-6211-STD set 99.00
 OBA-6211-010 set 99.00
 OBA-6211-020 set 99.00
 OBA-6211-030 set 99.00

CONNECTING ROD BUSHINGS

1949-53
 21A-6207 each 2.50

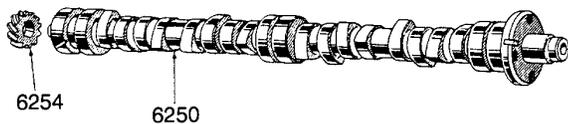

CAMSHAFT

1948-53, V-8
 EAB-6250 each 199.00



OIL PUMP DRIVER GEAR

1949-53, V-8
 18-6254-B each 30.00



DISTRIBUTOR DRIVE GEAR

1948-53, V-8
 7RA-6255 each 16.00

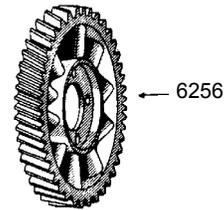

CAMSHAFT TIMING GEAR

1948-53, 239, V-8
 8BA-6256 each 48.00
 1952-56, F-1, 215, 223, 1954-56, 239, 256, 272, 292, 312
 EAA-6256-A each 25.00



CAMSHAFT BEARING SET

1948-53, V-8, Standard
 O1A-6261/62-AS set 42.00

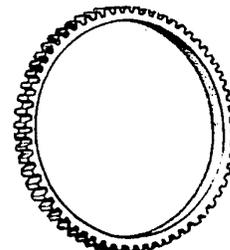

8BA-6384

FLYWHEEL RING GEAR

1948-53, Flywheel Ring Gear, V-8
 8BA-6384 each 44.00
 1948-51, 6 cyl. 226 and 50-53, 6 cyl. 254, 114 teeth
 8HA-6384 Discontinued 00.00

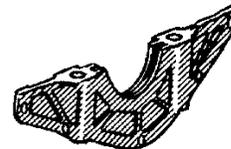

8RT-6410-S

1948-52, Flywheel Housing Cover, Metal, V-8
 8RT-6410-S each Discontinued



8BA-6411

1953, Flywheel Housing Cover Seal, Rubber, V-8
 8BA-6411 each 15.00

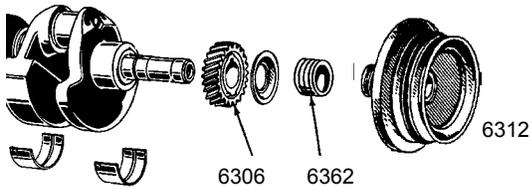

CRANKSHAFT RELATED PARTS

1948-53, Crankshaft Gear, V-8		
8BA-6306	each	38.00
1949-53, Crankshaft Pulley for wide belts		
8BA-6312-B	each	130.00
1948-53, Crankshaft Pulley Extension, V-8		
8BA-6362	each	5.00



MAIN BEARING SETS

1949-53, V-8, Complete Engine Set		
1BA-6330-STD	set	90.00
1BA-6330-010	set	90.00
1BA-6330-020	set	90.00
1BA-6330-030	set	90.00

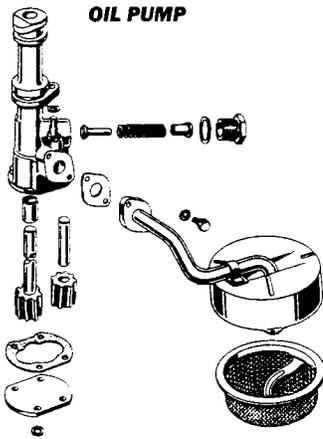

OIL PUMP

OIL PUMP

1948-53, F-1, 239, V-8		
8BA-6600	each	150.00

OIL PUMP REBUILDING KIT

1948-53, F-1, V-8		
8BA-6600-RKT	kit	110.00

COMPLETE VALVE KIT



1948-53, V-8, includes 16 Stainless Valves, 16 one piece Guides, 16 Springs, 16 Keepers, 16 Spring Retainers, 8 Valve Guide Seals, 16 Valve Guide Retainers

8BA-6505/10-KIT	each	225.00
-----------------------	------	--------



INTAKE MANIFOLD GASKET

1948-53, V-8		
8BA-6521	each	12.00

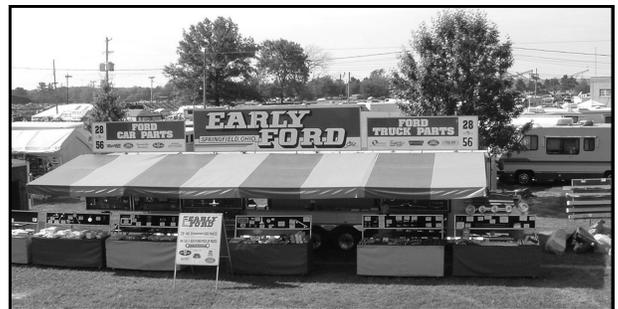

Call ahead to have your order delivered FREE to any of the major swap meets we attend this year. See page 132 for show schedule.

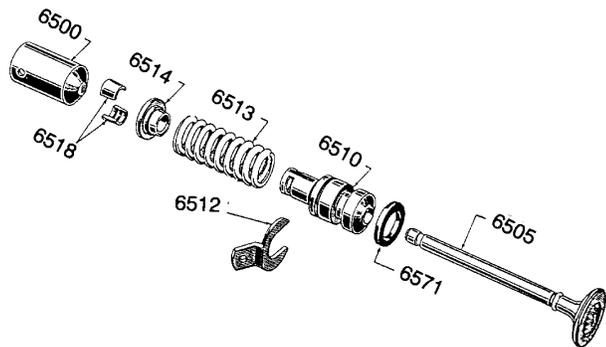

VALVE LOCKS, KEYS OR KEEPERS

1948-53, V-8		
7HA-6518 per valve	1.00

VALVE SPRING RETAINER

1948-51, 226, 6 cyl.		
7HA-6514 each	1.50
1948-50, V-8, Use with 8BA-6505 Valve		
8BA-6514 each	2.00

VALVE SPRINGS

1948-50, V-8, Use with 8BA Valve		
78-6513 each	4.00
1951-53, V-8, Use with 1BA Valve		
1BA-6513 each	3.00

VALVE GUIDE

1948-53, 239, V-8		
8BA-6510 each	5.00

VALVE GUIDE RETAINER

1948-53, V-8		
40-6512 each	.75

VALVE SEAL

1948-53, V-8, Rubber, for Intake Valve		
8BA-6571 each	.37



91A-6500-AJ



91A-6500-AJW

ADJUSTABLE VALVE TAPPETS

1948-53, 239, V-8, Adjustable		
91A-6500-AJ set of 16	200.00

ADJUSTABLE TAPPET WRENCHS

1948-53, V-8, Almost a must for adjusting 91A-6500-AJ		
91A-6500-AJW pair	10.00



6505

INTAKE VALVES

1948-50, 6 cyl.		
7HA-6507 each	25.00
1951, 226, 6 cyl.		
1HA-6507 each	12.00
1948-50, 239, V-8		
8BA-6505 each	10.00
1951-53, 239, V-8		
1BA-6505 each	14.00

EXHAUST VALVES

1948-50, 239, V-8		
8BA-6505 each	10.00
1948-50, 6 cyl.		
7HA-6505 each	10.00
1951-53, 239, V-8		
1BA-6505 each	14.00
1954-55, 239, V-8, 1956, 272		
B6A-6505-A each	9.00



OIL PUMP PICK-UP TUBE & COVER

1948-53, 239, V-8
8RT-6615 each 43.00



OIL PUMP SCREEN

1948-53, V-8
8BA-6623-A each 20.00



OIL FILTER ELEMENT

1948-52 V8, 1948-51 6Cyl.
7HA-6731-A each 15.00
1953-56, V-8 and 6 Cyl.
B2A- 6731-A . each

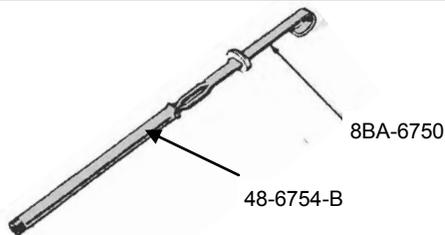

OIL DIPSTICK/TUBE

1948-53, Pickup, V-8, Painted
8BA-6750 each 20.00
1948-53, Pickup, V-8, Chrome
8BA-6750-CH each 25.00
1948-53, Pickup, V-8, Dipstick Tube, Cad plated
48-6754-B each 7.00



8BA-6766



HR-6763/6

OIL BREATHER CAP

1948-53, 239, V-8
8BA-6766 each 20.00

CHROME OIL FILLER TUBE AND CAP

1948-53, Triple chrome plated
HR-6763/6 kit 25.00



6781

OIL PAN GASKET SET

1948-53, V-8
8BA-6781 set 18.00

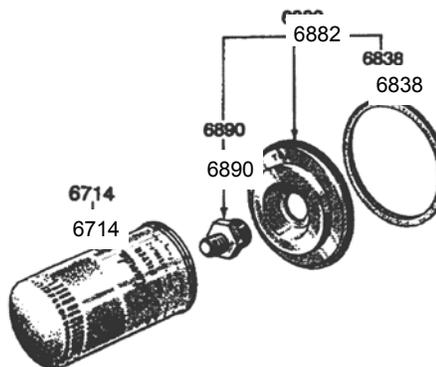

OIL FILTER CONVERSION KIT

1952-56, All Overhead Engines, Converts from original filter cartridge to modern spin-off filter
B7A-6882-A kit 30.00



UNIVERSAL JOINT

1948-56, F-1, F-100
21C-7039 each 20.00



TRANSMISSION PARTS

We have many more transmission parts—call with your needs.

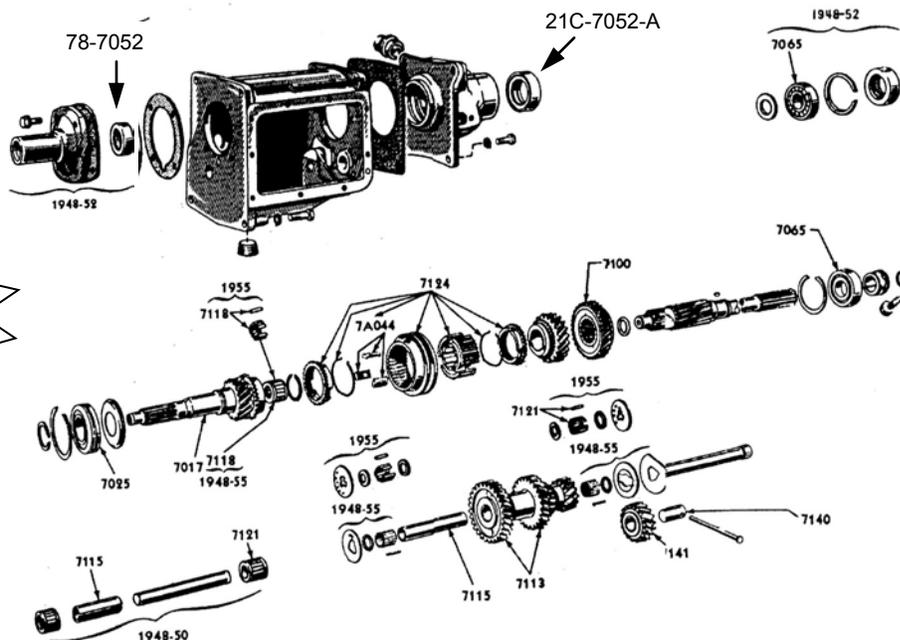

OVERDRIVE KICKDOWN SWITCH

1949-56, F-1
8A-6918-B each 25.00

TRANSMISSION SEALS

1948-52, F-1, Input Shaft Seal for 3 speed
78-7052 each 5.00
1948-56, F-1, Rear Housing Seal for 3 speed
21C-7052-A each 8.00

SYNCHRONIZER ASSEMBLY

1948-56, F-1, 3 speed, Complete assembly with the brass rings
O1A-7124 each 110.00

TRANSMISSION GASKET SET

1948-52, F-1, 3 speed
B-7153 set 12.00
1953-56, F-1, 3 speed



GEAR SHIFT BOOT

1948-52, For floor shift
99A-7242-B each 16.00



EMERGENCY BRAKE HANDLE BOOT

1948-52, Pickup, Black
EB-7000-B each 5.00

GEAR SHIFT



91C-7213



7C-7213



B6C-7213

1948-56, For 3 speed floor shift
91C-7213 each 16.00
1948-56, For 3 speed heavy-duty and 4 speed floor shift
BB-7213-A each 6.00
1948-55, For column shift
7C-7213 each 6.00
1956, Spear shape for column shift
B6C-7213 each 7.00

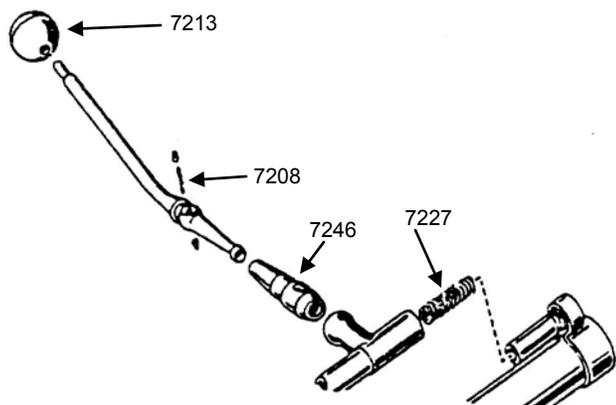

GEAR SHIFT LEVER INSULATOR PIN SPRING

1948-55, F-1, 3 speed column
 O1A-7208 each 1.00

GEAR SHIFT INSULATOR

1948-56, F-1, Rubber, For 3 speed
 O1A-7246-B each 8.00

1953-56, F-1, Rubber, For Automatic
 1M-7246-A each 8.00

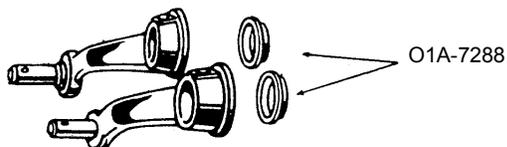

SHIFT LINKAGE TO TRANSMISSION SEAL

1948-52, F-1
 O1A-7288 each 6.00

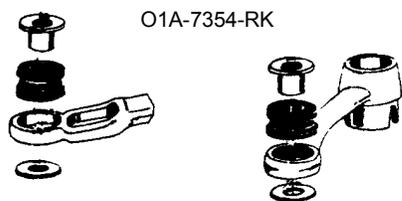

GEAR SHIFT LEVER GROMMET REPAIR KIT

1948-56, F-1, For column shift, requires 1 kit per truck
 O1A-7354-RK kit 15.00

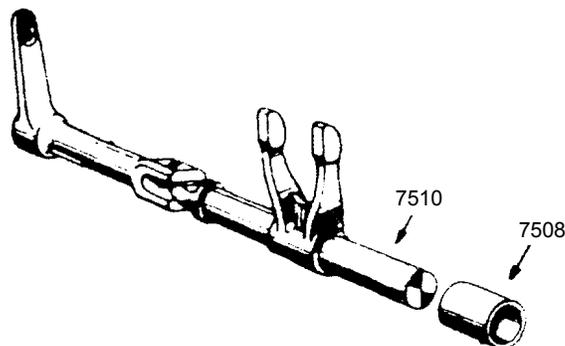

CLUTCH RELEASE SHAFT AND BUSHING

1948-52, F-1, F-2, Clutch Release Bushing
 40-7508 each 4.50

1948-52, F-1, F-2, Clutch Release Shaft
 O1A-7510 each 55.00

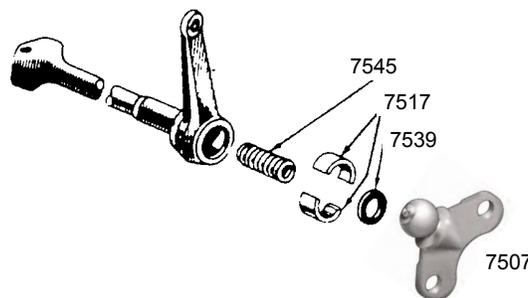

CLUTCH RELEASE EQUALIZER SHAFT BUSHING, HALF MOON STYLE

1948-52, F-1, F-2, F-3
 O1A-7517 pair 5.00

CLUTCH EQUALIZER BALL AND BRACKET

1948-52, F-1, F-2, F-3
 O1Y-7507 each Out of Production

CLUTCH RELEASE ARM SHAFT WASHER

1948-52, F-1, F-2, F-3, Rubber
 O1A-7539-A each .75

CLUTCH RELEASE ARM SHAFT SPRING

1948-52, F-1, F-2, F-3
 O1A-7545 each 2.00

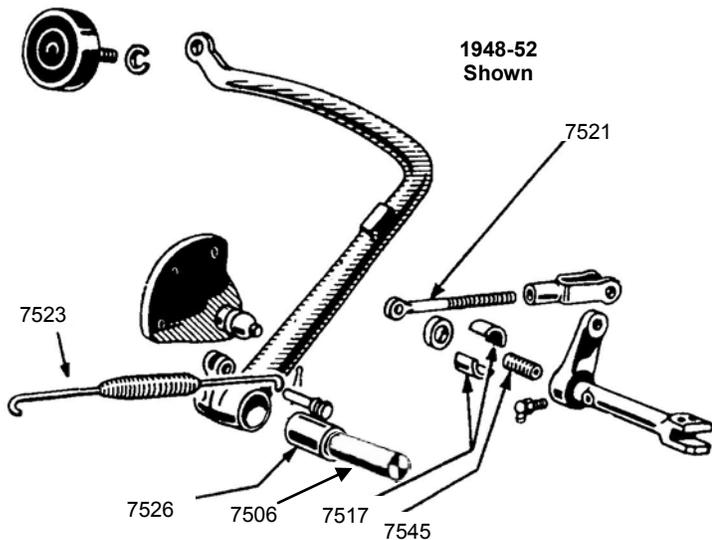

CLUTCH RELEASE LEVER ROD

1948-52, F-1 7RT-7521	each	15.00
1953-56, F-1, 10-9/16" long TAAA-7521-A	each	7.50



CLUTCH RETRACTING SPRING

1948-52, F-1, F-2, F-3 7RT-7523	each	7.00
1953-56, F-1, F-2, F-3 TAAA-7523-A	each	4.00



CLUTCH & BRAKE PEDAL BUSHING

1948-52, F-1 B-7526	each	5.50
------------------------------	------	------

CLUTCH & BRAKE PEDAL SHAFT

1948-52 All, except C.O.E. O1T-7506	each	22.00
--	------	-------

CLUTCH & BRAKE PEDAL BRACKET TO SHAFT BUSHING

1953-56, F-1 7EQ-5344-A	each	4.50
----------------------------------	------	------

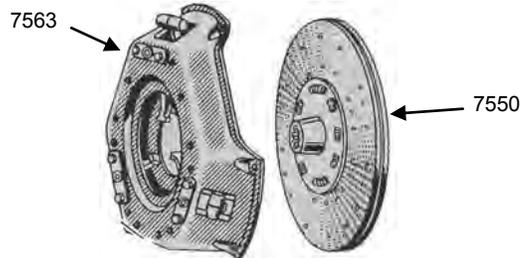

CLUTCH PRESSURE PLATE

1948-56, F-1, F-2, 10" 19A-7563	each	120.00
1948-56, F-2 through F-6, 11" 51A-7563	each	110.00
Core Charge		50.00

CLUTCH DISC

1948-56, F-1, F-2, 10" 51A-7550	each	60.00
1948-56, F2 through F6, 11" 81T-7550	each	60.00



ALIGNING TOOL

1948-56 7550-TOOL	each	8.00
----------------------------	------	------



THROWOUT BEARING

1948-56, F-1, F-2, F-3 78-7580	each	22.00
---	------	-------

THROWOUT BEARING SPRING

1948-52 48-7562	each	2.00
--------------------------	------	------

CLUTCH RELEASE BEARING HUB

1948-52 48-7561-A	each	20.00
----------------------------	------	-------

CLUTCH PILOT BEARING

1948-56, Ball Bearing B-7600	each	9.00
70-7600 Bronze Bushing	each	6.00

CLUTCH RELEASE ARM SEAL

1948-52 8A-7996	each	2.00
--------------------------	------	------





78-8100



41A-8100-C



1T-8100-A



RADIATOR CAP

1948-51, 4 lbs. pressure		
41A-8100-C	each	14.00
1948-51, 4 lbs. pressure, original style		
78-8100	each	25.00
1952-56, 4 lbs. pressure		
1T-8100-A	each	8.00

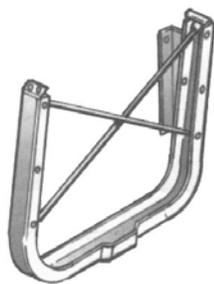

RADIATOR SUPPORT

1948-50, F-1		
7C-16138-B	each	299.00
1951-52, F-1		
1C-16138-B	each	299.00
1953-56, F-100		
B3C-16138-B	each	140.00

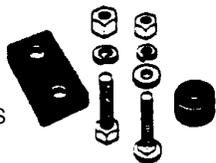

B6C-8125-S



BAAA-8125-S

RADIATOR SUPPORT TO FRAME PAD

1948-52, Usually takes 2, pad only		
8C-8124-A	each	3.00
1948-52, Includes springs, bolts, nuts, and pads		
7C-8124-KIT	kit	20.00
1953-55		
BAAA-8125-S	kit	20.00
1956		
B6C-8125-S	kit	20.00

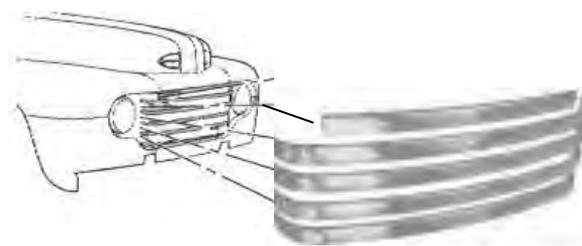

STAINLESS GRILLE BAR TRIM SETS

1948-50, F-1, F-2, Polished Stainless Steel, mounting clips included. Mounts to Grille Bar		
7C-8200-GBK	set of 5	170.00
1948-50, As above, without crank hole in bottom bar		
7C-8200-GBSM	set of 5	170.00
1948-50, As above, All long bars		
7C-8200-SR	set of 5	185.00



GRILLE ASSEMBLY

1948-50, Fiberglass Grille Assembly		
7C-8201-FG	each	300.00
1948-50, Steel		
7C-8201-ST	each	350.00
1948-50, Steel, Long Top Bar, Chrome Bars, Painted Headlight Panels		
7C-8201-BC	each	400.00
1948-50, Steel, Stock Top Bar, All Chrome		
7C-8201-C	each	425.00

GRILLE BARS ONLY

1948-50, Fiberglass replacement Grille Bars, state long or short		
7C-8335-FB	each bar	40.00

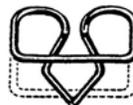

7C-16850-CL

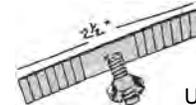

U-29000-CLAK

GRILLE BAR TRIM CLIPS

1948-50		
7C-16850-CL	each	1.00
Universal, snaps off to molding width, 10-23 3/4" stud		
U-29000-CLAK	pkg. of 10	10.00





1956 GRILLE

B6C-8200-B Chrome..... each 550.00
 B6C-8200-BL Black..... each 399.00

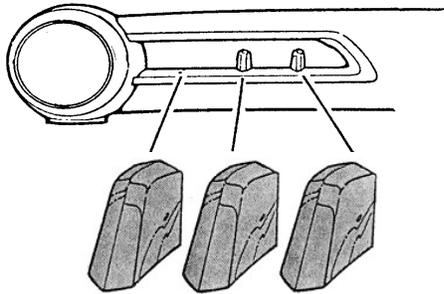

GRILLE TEETH

1953, A hole template is provided with the set, 6 pc. set
 BAAA-8164/5-B set 175.00

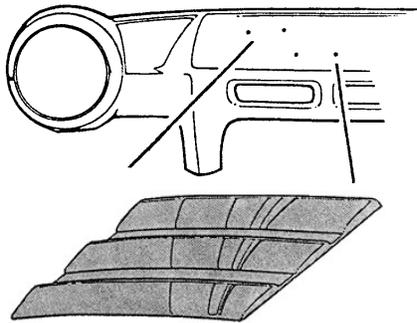

GRILLE HASH MARKS

1954, Zinc die cast Deluxe Model Grille Hash Marks. A standard pickup can be spruced up with the addition of these Hash Marks. A hole template is provided with set
 B4C-8251/2-A pair 135.00



GULL WINGS

1955, Pickup & Commercial, Includes all mounting hardware, special cup washers & drilling hole template
 B5C-8419/20-A pair 195.00

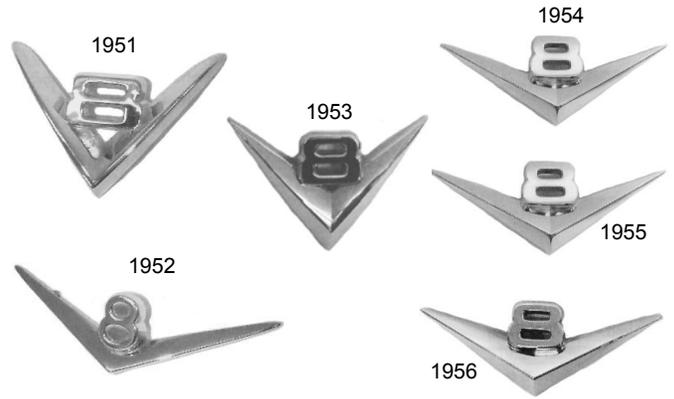

RADIATOR GRILLE EMBLEMS

1951, Chrome Plated
 1RC-8259 each 45.00
 1952, Chrome Plated, goes on Hood
 2C-16608-A each 45.00
 1953, Chrome Plated
 BAAA-8259-A each 60.00
 1954, Chrome Plated
 B4C-8259 each 60.00
 1955, Chrome Plated
 B5C-8259 each 60.00
 1956, Chrome Plated
 B6C-8259-A each 60.00

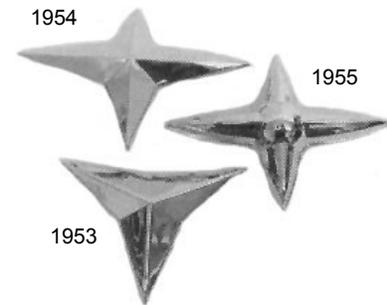

RADIATOR GRILLE STAR

1953, 6-cyl., 3 point star
 BAAA-8259-ST each 55.00
 1954, 6-cyl., 4 point star
 B4C-8259-ST each 55.00
 1955, 6-cyl., 4 point star
 B5C-8259-ST each 55.00



8190

UPPER GRILLE PANEL

1948-50, F-1, Panel where chrome Ford Letters or V-8 Emblems mount

7C-8190 each 165.00

1951-52, F1, As Above, with Ford Emblem holes

1HC-8190 each 185.00



RADIATOR GRILLE PANEL LETTERS

1948-50 and 1952, F-1, F-2, F-3, Die Cast Chrome

7C-8315-S set of 4 40.00



ENGINE SPLASH PAN

1948-52, Stamped Steel

7RC-6775-A each 45.00

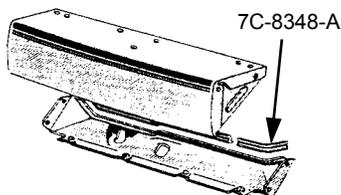

7C-8348-A

LOWER RADIATOR GRILLE SPLASH PAN TO RADIATOR SEAL

1948-52, 29"

7C-8348-A each 4.00

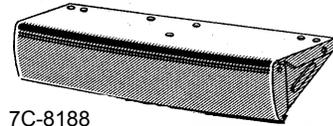

7C-8188

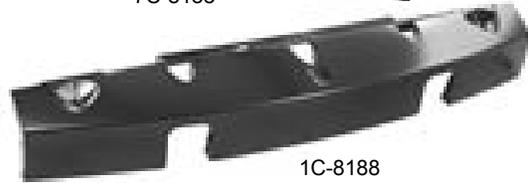

1C-8188

LOWER GRILLE VALANCE

1948-50, Steel

7C-8188-S each 175.00

1948-50, Fiberglass

7C-8188-F each 75.00

1951-52, Fiberglass

1C-8188 each 149.00

1951-52, Lower Grille Panel, Steel

1C-8188-ST each 225.00



LOWER GRILLE AIR DEFLECTOR

1951-52, Stamped Steel

1RC-8208 each 35.00



1C-8310/1

HEADLIGHT SUPPORT PANEL

1951-52, Headlight Support Panels, Die Stamped

1C-8310/1 pair 95.00



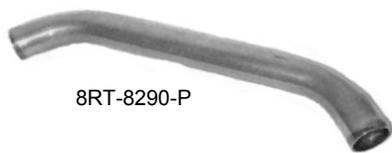

8RT-8290-P

UPPER RADIATOR HOSE/PIPE

1948-52, Upper Radiator Hose, Plain, Pipes only
8RT-8290-P pair 39.00

1948-52, Upper Radiator Hose, Chrome, Pipes only
8RT-8290-CH pair 85.00



8RT-8286-S

RADIATOR HOSE KITS

1948-52, V-8, Upper, 4 Hoses, 8 Clamps
8RT-8260-S kit 32.00

1948-52, V-8, Lower, 2 Hoses, 4 Clamps
8RT-8286-S kit 24.00



RADIATOR HOSE CLAMPS

1948-56, Upper Hose Clamp, 6 cyl., 1-7/8" O.D.
AB-8287 each 1.95

1948-56, Lower Hose Clamp, 6 cyl., 2-1/8" O.D.
B-8287 each 1.95

1948-53, Upper Hose Clamp, 8 cyl., 1-5/8" O.D.
8BA-8287 each 1.95

1954-56, Upper Hose Clamp, 239, 272, 292, 8 cyl., 1-7/8" O.D.
AB-8287 each 1.95

1948-56, Lower Hose Clamp, 8 cyl., 2-1/8" O.D.
B-8287 each 1.95



WATER PUMP REBUILDING KIT

1948-53, V-8
A8C-8591kit 27.50



8RA-8501-LH

8RT-8501-RH

NEW WATER PUMPS

1948-52, F-1, F-2, F-3, Right Hand for 239 V-8
8RT-8501 each 75.00

1948-52, F-1, F-2, F-3, Left Hand for 239 V-8
8RT-8502 each 75.00

1953, Right Hand, V-8, with wide belt
8BA-8501 each 95.00

1953, Left Hand, V-8, with wide belt
8BA-8502 each 95.00

WATER PUMP TO BLOCK GASKET

1948-53, V-8
8BA-8507 each 1.00



21T-8146

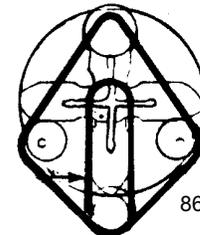

8620

FAN & GENERATOR BELTS

1948-51, 6 cyl.
7HT-8620 each 20.00

1948-53, F-1, F-2, F-3, V-8, Fan, Wide Belt
21A-8577 each 13.00

1948-53, F-1, F-2, F-3, V-8, Generator, Wide Belt
7RA-8620 each 19.50

1953, F-100, V-8, Generator, Narrow Belt
8BA-8620 each 18.00

1953, F-1, V-8, Fan, Narrow Belt
8BA-8577 each 15.00

1954-55, F-1, V-8, Fan
B4TZ-8620-B each 18.00

FAN SHROUD

1948-52, V-8
21T-8146 each 125.00

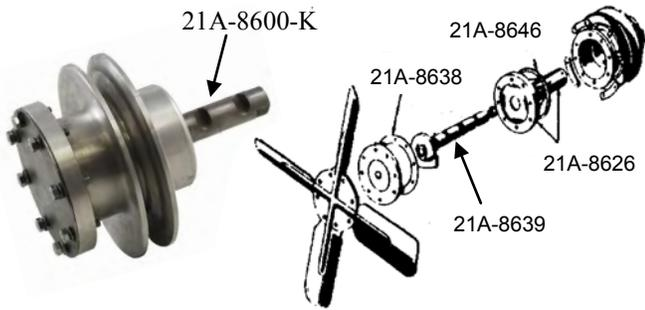

FAN AND HUB PARTS

1942-52, Bearing Fan Spindle, V-8 21A-8626	each	89.00
1948-52, Gasket for Fan Spacer, V-8 21A-8638	each	2.00
1942-52, Gasket for rear of Fan, V-8 21A-8646	each	2.00
1942-52, Fan Impeller and Shaft, V-8 21A-8639	each	40.00

FAN HUB KIT

1942-52 Pickup and 1942-48 Passenger, V-8, sealed bearings, aluminum body, steel shaft. Includes fan-mounting hardware. 21A-8600-K	kit	160.00
---	-----	--------

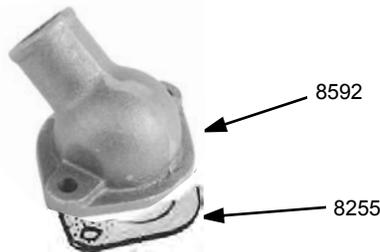

WATER OUTLET HOUSING

1948-53, F-1, 239, V-8, Polished Aluminum 1BA-8592	each	19.00
---	------	-------

THERMOSTAT HOUSING GASKET

1948-53, V-8 8BA-8255	each	1.00
1954-56, V-8 B5A-8255-A	each	1.50
1948-51, 6 cyl. 7HA-8255	each	1.50
1952-56, 6 cyl. EAG-8255-A	each	1.50



THERMOSTAT

1948-51, 6 cyl. 8HT-8575-B	each	12.00
1948-53, V-8 8BA-8575	each	8.00
1952-56, 6 cyl. and 1954-56, 8 cyl. C2AZ-8575-B	each	8.00



11C-9030



18-9030-V8

GAS CAP

1948-50, Replacement type, Stainless Steel 11C-9030	each	10.00
1948-50, As Original, Stainless Steel 18-9030	each	25.00
1948-50, Non-locking with V-8 logo, Stainless Steel 18-9030-V8	each	25.00
1951-56, Stainless Steel 8A-9030	each	8.00

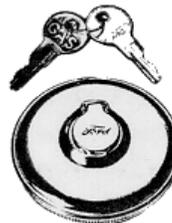

48-18416



O1A-18416-A

LOCKING GAS CAP

1948-50, Ford Script, Chrome 48-18416	each	35.00
1951-56, Chrome O1A-18416-A	each	40.00
1948-50, Chrome, As Above O1A-18416-B	each	40.00

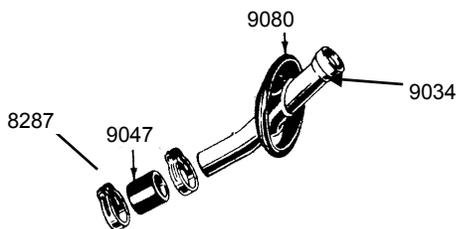

GAS TANK FILLER PIPE

1948-50, Chrome		
7C-9034-CH	each	50.00
1951-52, Chrome		
1C-9034-CH	each	50.00
1953-55		
B4C-9034-A	each	40.00
1956		
B6C-9034-A	each	40.00

GAS NECK CONNECTOR HOSE

1948-52		
21A-9047	each	7.50
1953-56		
78-9047	each	12.00

GAS NECK CONNECTOR HOSE CLAMPS

1948-52		
11A-8287	each	1.95
1953-56		
B-8287	each	1.95

GAS TANK NECK GROMMET

1948-52		
7C-9080	each	18.00
1953-55		
BAAA-9080	each	20.00
1956		
B6C-9080	each	15.00
1948-52, Panel Only		
7C-9080-P	each	25.00
1953-56, Panel Only		
BAAA-9080-A	each	25.00

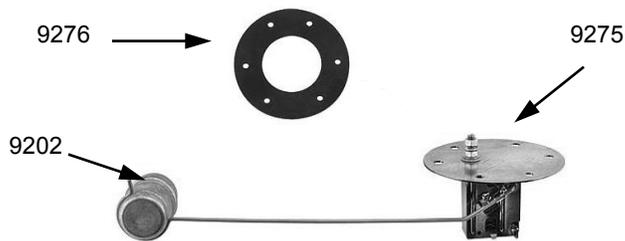

GAS TANK SENDING UNIT

1948-52, Includes float, gasket		
7C-9275-6V	each	40.00
1953-55, As Above		
BAAA-9275-6V	each	40.00
1956, As Above, 12V		
B6C-9275	each	60.00

GAS TANK SENDING UNIT FLOAT BRASS

1948-56		
O1A-9202	each	10.00

GAS TANK SENDING UNIT GASKET

1948-56		
68-9276	each	2.00



GAS TANK OUTLET TO FLOOR SEAL

1948-52		
7C-9136-A	each	8.00

GAS TANK TO FLOOR BUMPER

1948-52, Set of 4		
01A-16188	set	4.00

GAS TANK TO FLOOR PAD

1948-52		
21C-9299	pair	8.00

TOOL TRAY RUBBER BUMPER

1948-52, 2 required		
8A-8167-A	each	2.00



BAAA-9002

GAS TANK

1948-52, Pickup 7C-9002	each	225.00
1953-55, Pickup, 17 Gallon BAAA-9002	each	225.00
1956, Pickup B6C-9002	each	249.00

GAS LINE

1948-52, Fuel Tank to Fuel Pump, Pre-Bent 7C-9282	each	50.00
--	------	-------

GAS LINE GROMMET

1956, Where Gas Line goes through floor 48-17265	each	4.00
---	------	------

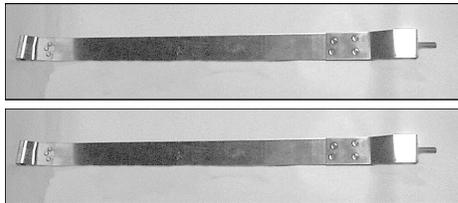

GAS TANK STRAPS

1953-55, Stainless Steel, in pairs only TAAA-9054/57-SS	pair	50.00
--	------	-------

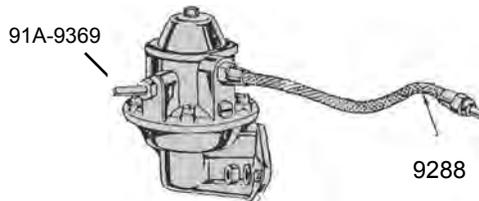

FUEL LINE

1948-50, 6 & 8 cyl., From Firewall to Fuel Pump 7HC-9288-A	each	12.00
1951-53, 6 & 8 cyl., as above 1A-9288-A	each	9.00
1948-53, V-8, Pump to Carb., with Fittings, Copper 91A-9369	each	5.00



FUEL PUMP

1948-51, 6 cyl., single action 7HA-9350	each	56.00
1948-53, V-8 7RA-9350-A	each	60.00
1955-56, F-1, 272, 292, 312, 352, 361, 391 B6C-9350	each	59.00

ELECTRIC FUEL PUMP

1948-55, All, 6 volt EFP-9350-A6	each	75.00
1956, 12 volt EFP-9350-A12	each	75.00

FUEL PUMP PUSH ROD AND BUSHING

1948-53, F-1, 239 V-8, Fuel Pump Push Rod EAB-9400-A	each	15.00
1948-53, 239 V-8, Fuel Pump Push Rod Bushing 8BA-6025	each	5.00

FUEL PUMP DIAPHRAGM

1949-53 68-9398-A	each	15.00
----------------------------	------	-------

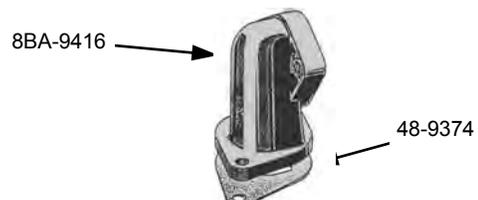

FUEL PUMP STAND

1948-53, 239 V-8 8BA-9416	each	24.00
------------------------------------	------	-------

FUEL PUMP MOUNTING GASKET

1948-53, All models 1GA-9417	each	1.00
---------------------------------------	------	------

FUEL PUMP STAND TO INTAKE GASKET

1948-53, V-8 48-9374	each	1.00
-------------------------------	------	------



41A-9278



B6A-9278

OIL PRESSURE SENDING UNIT

1948-53, 6 volt		
41A-9278	each	40.00
1954-56, 12 volt, with warning light		
B6A-9278	each	10.00

8A-10990



8A-10884

TEMPERATURE SENDER

1948-55, 6 volt single post, fits into head or block		
8A-10884	each	45.00
1948-55, 6 volt double post		
8A-10990	each	45.00
1956, 12 volt		
B6C-10884	each	60.00



EXHAUST MANIFOLD GASKETS

1948-53, 239 V-8		
18-9433	set of 8	7.50
1955-56, Exhaust Manifold Gasket Set		
B7AZ-9433-A	set	20.00

SMITHY MUFFLERS

A true 50's sound that is resonated through Smithy's legendary 22" mufflers. 3-1/2" diameter, 2" inlet/outlet
 SM-5120 pair 80.00



CARBURETOR

1948-53, V-8, New, with new top and body, with gasket, made on original tooling		
8RT-9510-N	each	385.00

CARBURETOR REBUILDING KITS

1948-51, 226, 6 cyl., 1v		
7HA-9590	kit	23.00
1948-56, V-8, 2v		
81A-9590	kit	24.00
1952-56, 223, 6 cyl., Holley 1v		
B2A-9590-A	kit	39.00

CARBURETOR TO MANIFOLD GASKET

1948-52, V-8		
40-9447	each	2.00
1952-56, F-1, 133, 170, 233, 6 cyl.		
C1TZ-9447-A	each	1.25

CARBURETOR FLOATS

1948-56, V-8		
78-9550	each	14.00



ACCELERATOR TO CARBURETOR ROD

1948-53, V-8, 10.75"		
91A-9747	each	8.00

1948-52 KNOBS



HEATER BLOWER MOTOR, AIR, DEFROST AND TEMPERATURE CONTROL KNOB

1948-50		
7C-9700 each	7.00
1951-52		
1C-9700 each	7.00



CHOKE KNOB

1948-50		
7C-9703 each	7.00
1951-52		
1C-9703-A each	7.00



THROTTLE KNOB

1948-50		
7C-9778 each	7.00
1951-52		



HEADLIGHT SWITCH KNOB WITH SHAFT

1948-50		
7C-11661 each	9.00
1951-52		
1C-11661-A each	9.00



CIGAR LIGHTER KNOB

1948-50		
7C-15052 each	8.00
1951-52		
1C-15052-A each	8.00

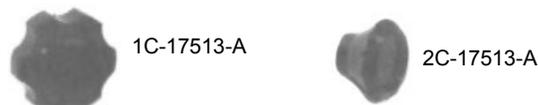

WIPER ON-OFF KNOB

1948-50		
1C-17513-A each	6.50
1951-52		
2C-17513-A each	7.00

ASH TRAY KNOB

1948-50		
7C-8101656 each	6.00

GEAR SHIFT KNOBS



1948-56, For 3 speed floor shift		
91C-7213 each	15.00
1948-56, For 3 speed heavy-duty and 4 speed floor shift		
BB-7213-A each	6.00
1948-55, For column shift		
7C-7213 each	6.00
1956, Spear shape for column shift		
B6C-7213 each	7.00

1953-56 KNOBS



1948-55
Gear Shift
Knob
See P. 35

Headlight

Choke, Throttle,

Cowl Vent

Wiper

Gear Shift 1956

Turn Signal

Cigar Lighter

Glove Box

CHOKE KNOB

1953-56
BAAA-9700-C each 6.00

THROTTLE KNOB

1953-56
BAAA-9700-T each 6.00

DEFROSTER KNOB

1953-56
BAAA-9700 each 6.00

HEATER BLOWER SWITCH KNOB

1953-56
BAAA-9700-HB each 6.00

HEATER TEMPERATURE CONTROL KNOB

1953-56
BAAA-9700 each 6.00

FRESH AIR PULL KNOB

1953-56
BAAA-9700-AP each 6.00

HEADLIGHT SWITCH KNOB W/SHAFT

1953-54
BAAA-11661 each 9.00

HEADLIGHT SWITCH KNOB W/SHAFT

1955-56
B6C-11661 each 9.00

CIGAR LIGHTER KNOB

1953-56
BAAA-15052 each 8.00

WIPER KNOB

1953-56
BAAA-17513 each 7.00

GLOVE BOX DOOR KNOB

1953-56
BAAA-8101656-A each 6.50

COWL VENT KNOB

1953-56
BAAA-8102145 each 6.50

ASH TRAY KNOB

1953-56
BAAA-8101656-A each 6.00

TURN SIGNAL LEVER KNOB

1953-56
1A-13305 each 6.00

DASH KNOB KITS

1953-55, Long Shaft, Molded Black Plastic, 5 knobs
BAAA-9270-K kit 20.00

1956, Short Shaft, Molded Black Plastic, 4 knobs
B6C-9270-K kit 20.00

DASH BEZELS



IGNITION

1953-56
BAAA-10852-IG each 8.00

CHOKE

1953-56
BAAA-10852-C each 8.00

THROTTLE

1953-56
BAAA-10852-T each 8.00

WIPER

1953-56
BAAA-10852-W each 8.00

LIGHTS

1953-56
BAAA-10852-L each 8.00

LIGHT SWITCH BEZEL NUT

1953-54
FAB-11662-A each 7.00

1955-56
C2TZ-11650-A each 7.00



ACCELERATOR PEDAL ROD TO FLOOR SEAL

1948-52
7C-8112177 each 25.00

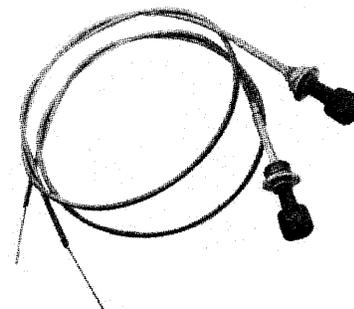

THROTTLE OR CHOKE CABLE AND KNOB KIT

1953-56, Throttle Cable, can also be used as Choke Cable, black plastic Knob is molded directly onto the cable
BAAA-9700-TA each Discontinued

CHOKE AND THROTTLE CABLE

1948-56, F-1, F-2, F-3, Does not include Knob
7C-9700-U each 13.00

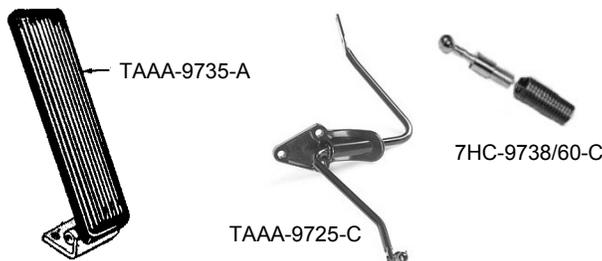

ACCELERATOR PEDAL

1948-56, All
TAAA-9735-A each 15.00

ACCELERATOR PEDAL LINKAGE

1953-56, 6 Cyl. and 1954-56 V-8
TAAA-9725-C each 47.50

ACCELERATOR PEDAL ROD AND LINKAGE

1948-52
7HC-9738/60-C kit 12.00

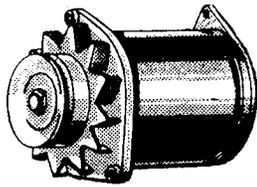

GENERATOR BRUSH SET

1948-56 O1A-10043	set	4.00
----------------------------	-----	------

GENERATOR BEARING

1948-56, Front B-7600	each	9.00
--------------------------------	------	------

GENERATOR REAR END PLATE BUSHING

1948-55 78-10128	each	1.50
---------------------------	------	------

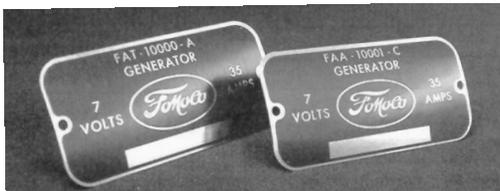

METAL TAGS

1948-53, Generator Metal Tag CC-101	each	7.00
1954-55, Generator Metal Tag CC-102	each	7.00
1948-53, Voltage Regulator Metal Tag CC-104	each	7.00
1948-55, Starter Metal Tag CC-103	each	7.00



10505

VOLTAGE REGULATOR

1948-55, 6 volt 51A-10505	each	45.00
1956, 12 volt B6A-10505	each	45.00



6A-11500

DASH STARTER BUTTON

1948-51, Chrome Button, 6 volt 6A-11500	each	7.00
1948-51, As Above, Black Button, 6 volt 21C--11500	each	13.00
1952-55, 6 volt and 1948-56, 12 volt 2C-11500	each	17.50

May require filing of bell housing

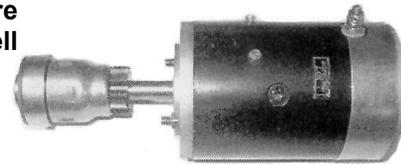

STARTER (FLATHEAD)

1948-53, V-8, 6 volt, Except 60 H.P. 18-11002-N6	each	180.00
1948-53, As Above, 12 volt 18-11002-N12	each	180.00



STARTER DRIVE ASSEMBLY

1948-53, V-8, Standard Transmission, modern style B-11350	each	45.00
--	------	-------



O1A-11450

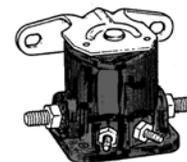

B6A-11450-A

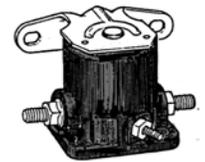

B5A-11450-A

STARTER SOLENOID

1948-51, Original style, steel case O1A-11450	each	25.00
1948-51 21A-11450	each	15.00
1952-55 B5A-11450-A	each	30.00
1956, 12 volt B6A-11450-A	each	15.00



IGNITION KEY BLANK

1948-52		
1A-3685-A each	5.00
1953-56		
BA-3685-A each	4.00



IGNITION CYLINDER AND KEY

1948-52, Has 1949-50 style key		
8A-11582-A each	25.00
1953-56		
BA-11582 each	15.00



UNIVERSAL IGNITION SWITCH

Works for 1948-52, has accessory and start positions		
U-11572 each	20.00



IGNITION SWITCH HOUSING

1948-50, No Cylinder and Keys		
6A-11572-B	60.00
1951-52, No Cylinder and Keys		
OL-11572-A each	60.00
1953-55, No Cylinder and Keys		
FAA-11572-A	30.00
1956, Can be used on 1953-55, Need spacer B7C-11597-A to hold in dash		
B6C-11572 each	18.00



HEADLIGHT SWITCH KNOB AND SHAFT

1948-50		
7C-11661 each	9.00
1951-52		
1C-11661 each	9.00
1953-54		
BAAA-11661 each	9.00
1955-56		
B6C-11661 each	9.00



IGNITION SWITCH TO DASH SPACER

1956		
B7C-11597-A each	10.00

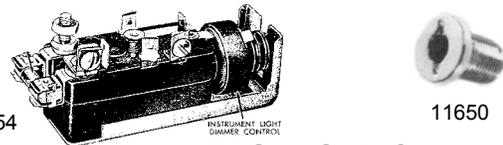

HEADLIGHT SWITCH

1948-50, Less Knob		
11A-11652 each	40.00
1951-54, Less Knob		
FAA-11654-A each	45.00
1955, Less Knob		
B5T-11654-A each	66.00
1956, 12-Volt, Less Knob		
B7A-11654-A each	55.00



IGNITION SWITCH BEZEL

1948-50, Stainless		
OA-11580 each	15.00
1951-52, Stainless		
OL-11580 each	15.00
1953-56, Chrome		
BAAA-10852-IG each	8.00

LIGHT SWITCH TO INSTRUMENT PANEL NUT

1948-50		
11A-11652-NUT each	5.00
1953-54		
FAB-11662-A each	7.00
1955-56		
C2TZ-11650-A each	7.00



8BA-12029

IGNITION COIL

1948-55, 6 volt
8BA-12029 each 25.00

1956, 12 volt
B6A-12029-B each 22.00

COIL BRACKET

1948-53
8BA-12043 each 15.00



8BA-12043



DISTRIBUTOR CAP

1948-56, 6 cyl.
7HA-12106 each 10.00

1948-56, V-8
FAB-12106-A each 10.00



DISTRIBUTOR GROUND LEAD WIRE

1948-53
7RA-12264 each 4.00



IGNITION POINTS

1948-53, V-8 and 1948-56, 6 cyl.
7RA-12171 set 4.50

1954-56, V-8
FAB-12171 set 4.50



IGNITION ROTOR

1948-56, All 6 cyl. and 8 cyl.
FAA-12200-B each 3.50



IGNITION CONDENSOR

1948-56, All 6 cyl. and 1949-56, 8 cyl.
7RA-12300 each 4.50



DISTRIBUTOR REPAIR KIT

1948-53, 239, V-8 and 1948-56, 6 cyl., Includes Points, Rotor and Condensor
A7A-12000-B kit 12.00

1954-56, V-8
FAB-12000-K kit 12.00



IGNITION COIL BALLAST RESISTOR

Heavy Duty Porcelain Resistors have a 200 watt rating and use threaded terminal connections for better wire retention.

M-700 each 18.00



DISTRIBUTOR VACUUM ADVANCE

1948-56, 6 cyl. and 1948-53, V-8
7RA-12370-B each 30.00



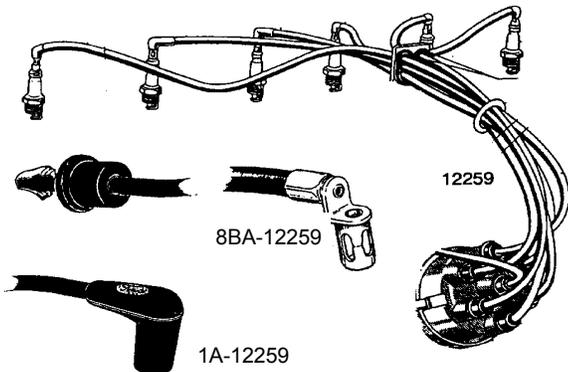

SPARK PLUG WIRE SET

1948-50, V-8		
8BA-12259 set	63.00
1948-51, 6 cyl.		
7HA-12259-S set	56.00
1951-53, 8 cyl., with plain Plug Wire Ends		
B1A-12259-S set	69.00
1951-53, 8 cyl., with Ford Script Plug Wire Ends		
1A-12259 set	89.00
1954-56, 272, 292, 312		
B5S-12259-S set	44.00



SPARK PLUGS

1948-53, F-1, 6 & 8 cyl.		
7RA-12405 each	3.50
1954-56, F-1, 6 & 8 cyl.		
B7A-12405-A each	4.00



IGNITION WIRE MOUNTING BRACKET KIT

1954-56, 239, 272, 292, 312		
FAA-12111-A kit	25.00



SPARK PLUG WIRE MOUNTING GROMMETS

1954-56, Rubber, set of 4		
FAA-12297-K set	20.00

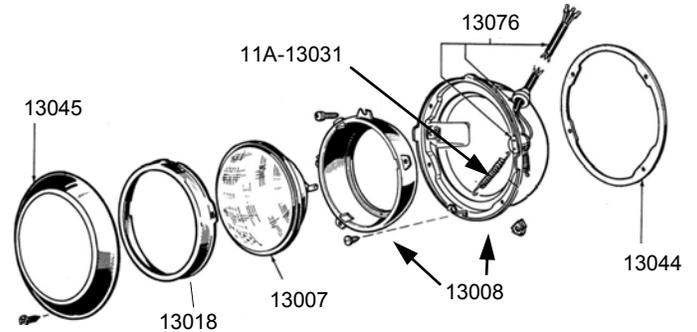

HEADLAMP BULB

1948-55, 6 volt		
B5AF-13007 each	21.00
1948-56, 12 volt		
B6AF-13007 each	12.00

HEADLAMP DOOR

1948-55, Stainless Steel		
B5CZ-13045 each	25.00
1956, Stainless Steel		
B6CZ-13045 each	25.00



7C-13045-HK



B6C-13045-CL

HEADLAMP DOOR SCREWS

1948-56,		
7C-13045-HK pair	1.00

HEADLAMP DOOR TO GRILLE CLIP

1956, USA Made, use 4, 2 for each ring		
B6C-13045-CL each	7.00

HEADLAMP BULB RETAINER RING

1948-56, Stainless		
O1A-13018-C each	15.00

RETAINING RING SCREW KIT

1948-56, 6 screws, does 2 rings		
O1A-13018-HK each	4.00

HEADLAMP BUCKET TO FENDER GASKET

1948-56		
11A-13044 each	4.00

HEADLAMP BUCKET SPRING

1948-56, 2 per headlamp needed		
11A-13031 each	2.00

HEADLAMP BUCKET

1948-55		
1C-13008-A each	75.00
1956		
B6C-13008-A each	85.00





HEADLAMP DIMMER SWITCH

1948-56
8A-13852 each 18.00



HEADLAMP SOCKET AND WIRE

1948-51
11A-13076-A each 24.00

1952-55
B5T-13076-A each 25.00

1956
B6T-13076-A each 35.00



HEADLAMP BUCKET WIRING GROMMET

1948-56
51A-13077 each 2.00



7RC-8104



7RC-8105



8C-13078-C

GRILLE AIR DEFLECTORS

1948-51, Right Side
7RC-8104 each 20.00

1948-51, Left Side
7RC-8105 each 20.00

1948-52, Headlight Wire Grommet
8C-13078-C each 4.00

PARK LAMPS



PARK LAMPS

1948-50, Polished Stainless Steel Rim, complete with glass lens, socket and wire
7RC-13200 each 35.00



PARK LAMPS

1951-52, Painted Rim as original
1C-13200-A each 35.00

1951-52, Polished Stainless Steel Rim, dual element bulb
1C-13200-SS each 40.00



PARK LAMPS

1953-54, Painted Rim as original
BAAA-13200-A each 35.00

1953-54, Polished Stainless Steel Rim, dual element bulb
BAAA-13200-SS each 40.00

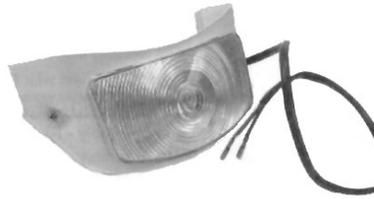

PARK LAMPS

- 1955, With Polished Stainless Rim, dual element bulb
B5C-13200-SS each 40.00
- 1956, With Polished Stainless Steel Rim, dual element bulb
B6C-13200-SS each 40.00



1C-13210-SS



B6C-13210-SS

STAINLESS PARK LAMP DOOR

- 1951-52, Polished Stainless
1C-13210-SS each 15.00
- 1953-54, Polished Stainless
FAE-13210-SS each 15.00
- 1955, Polished Stainless
B5C-13210-SS each 20.00
- 1956, Polished Stainless
B6C-13210-SS each 20.00

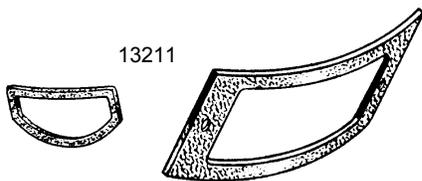

13211

PARK LAMP LENS GASKET

- 1948-50
7RC-13211-WS pair 4.00
- 1951-52
1C-13211 pair 6.00
- 1953-54
FAE-13211 pair 5.00
- 1955-56
B5C-13211 pair 5.00

PARK LAMP LENS



- 1948-50, Glass, clear
7RC-13208-G each 8.50
- 1948-50, Plastic
7RC-13208-P each 7.00
- 1948-50, Plastic, Amber color
7RC-13208-AMB each 10.00



- 1951-52, Clear
1C-13208-A each 9.50
- 1951-52, Amber color
1C-13208-AMB each 10.00



- 1953-54, Clear
BAAA-13208-A each 9.50
- 1953-54, Amber
BAAA-13208-AMB each 10.00



- 1955-56, Clear
B5C-13208-A each 9.50
- 1955-56, Amber
B5C-13208-AMB each 10.00

TAIL LIGHT KITS

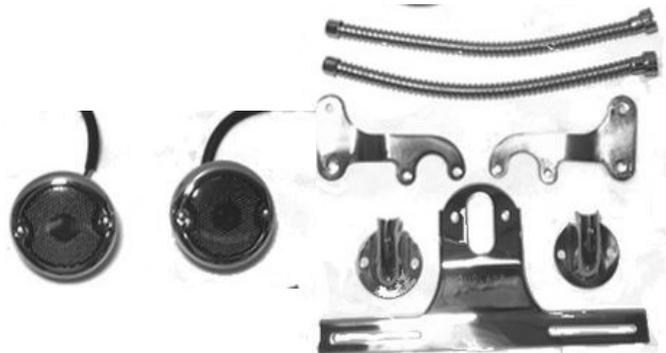

1948-54 Round Style, Stainless Steel, Includes Left and Right Tail Lights, 2 Brackets, 2 Shields, 2 Conduits, 1 License Plate Bracket

7C-13402/3-KL kit 129.00

1948-54 As Above, with LED lights,
7C-13402/3-KL-LED kit 173.00

1948-54 Less License Bracket, Lights With No License Light
7C-13402/3-KS kit 119.00

1948-54 As Above, with LED lights
7C-13402/3-KS-LED kit 149.00



1955-56 Shield Style, Stainless Steel, Includes Left and Right Tail Lights, 2 Brackets, 2 Shields, 2 Conduits, 1 License Plate Bracket

BAAA-13402/3-KL kit 135.00

1955-56 As Above, with LED lights, Chrome
BAAA-13402/3-KL-LED kit 189.00

1955-56 Less License Bracket, Lights With No License Light, Stainless Steel
BAAA-13402/3-KS kit 125.00

1955-56 As Above, with LED lights, Chrome
BAAA-13402/3-KS-LED kit 169.00

TAIL LAMPS



40-13402-S

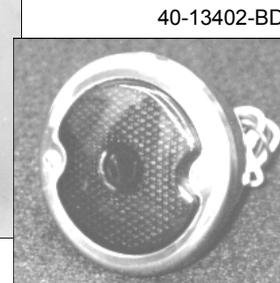

40-13402-BD

TAIL LAMPS

1948-54, F-1, Right Hand, round style, all Stainless Steel, glass lens

40-13402-S each 30.00

1948-54, F-1, As Above with Blue Dot Installed
40-13402-BD each 42.00

1948-54, F-1, Left Hand, all stainless
40-13403-S each 30.00

1948-54, F-1, As Above, with Blue Dot installed
40-13403-BD each 42.00

1948-54, F-1, Right Hand, Painted Black
48-13402-DR each 30.00

1948-54, F-1, Left Hand, Painted Black
48-13403-DL each 30.00



11A-13405

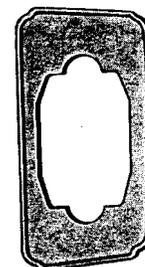

11A-13420

TAIL LAMPS

1948-56, Panel, Right Hand, Chrome Plated, Glass Lens

11A-13405-R each 65.00

1948-56, Panel, As Above, Left Hand
11A-13405-L each 65.00

1948-56, Tail Lamp Pads
11A-13420 each 6.00





BAAA-13404-A



BAAA-13404-SSFB

PLAIN TAIL LAMPS

- 1953-56, F-1, Right Hand, Shield Type, painted black
BAAA-13404-A each 25.00
- 1953-56, F-1, As Above, Left Hand
BAAA-13405-A each 25.00

STAINLESS TAIL LAMPS

- 1953-56, F-1, Right Hand, Stainless Steel Body
BAAA-13404-SS each 32.00
- 1953-56, As Above w/ Ford Script & Blue Dot Lens
BAAA-13404-SSFB each 45.00
- 1953-56, F-1, Left Hand, Stainless Steel Body
BAAA-13405-SS each 32.00
- 1953-56, As Above w/ Ford Script & Blue Dot Lens
BAAA-13405-SSFB each 45.00



BAAA-13470



7C-13470

TAIL LAMP MOUNTING BRACKETS

- 1948-52, F-1, Left Hand, plain steel
7C-13470 each 8.00
- 1948-52, F-1, Left Hand, polished stainless
7C-13470-SS each 15.00
- 1948-52, F-1, Right Hand, plain steel
7C-13471 each 8.00
- 1948-52, F-1, Right Hand, polished stainless
7C-13471-SS each 15.00
- 1953-56, F-1, Right or Left, plain steel
BAAA-13470 each 8.00
- 1953-56, F-1, Right or Left, polished stainless
BAAA-13470-SS each 15.00

LED TAIL LIGHTS



1955-56



1948-54

- 1955-56, Right Side, Chrome, no License Lens
FTL5012LEDR each 55.00
- 1955-56, Left Side, Chrome, with License Lens
FTL5012LEDL each 65.00
- 1948-54, Right Side, Chrome, no License Lens
FTL3336LEDAR each 45.00
- 1948-54, Left Side, Chrome, with License Lens
FTL3336LEDAL each 59.00

LED TAIL LIGHT LENSES



1955-56



1948-54

- 1948-56, Panel,
FTL4101LEDeach 26.00
- 1948-54, Right Side, no License Lens
FTL3336LEDReach 27.00
- 1948-54, Left Side, with License Lens
FTL3336LEDLeach 36.00
- 1955-56, Left Side, with License Lens
FTL53566LEDBL each 49.00
- 1955-56, Right Side, no License Lens
FTL53566LEDBR each 35.00



STOP LIGHT SWITCH

- 1948-56
11A-13480 each 6.00





40-13450-G



11A-13450-G

TAIL LAMP LENS

1948-54, F-1, Round, Glass	
40-13450-G	each 8.00
1948-54, F-1, Round, glass with Blue Dot installed	
40-13450-BD	each 16.00
1948-56, Panel Truck, Glass	
11A-13450-G	each 8.00
1948-56, Panel Truck, glass with Blue Dot installed	
11A-13450-BD	each 16.00

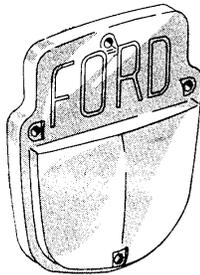

TAIL LAMP LENS

1953-56, F-1, Shield Style, plastic with Ford block letters	
FAA-13450-B	each 15.00

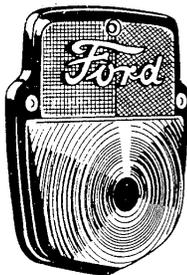

TAIL LAMP LENS

1953-56, F-1, Shield Style, plastic with chrome Ford script	
B5C-13450-FS	each 15.00
1953-56, As Above with Blue Dot	
B5C-13450-BD	each 20.00



TAIL LAMP SOCKET AND PIG TAIL WIRE

1948-52, F-1	
O1C-13410	each 11.00
1953-56, F-1	
BAAA-13410	each 6.00



B5C-13447

TAIL LAMP LICENSE LENS GASKET

1948-54, F-1, Round Style Tail Lamp	
40-13447	each 2.00
1955-56, F-1, Shield Style Tail Lamp	
B5C-13447	each 2.50

40-13461



B5C-13461

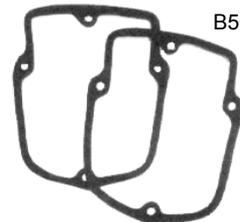

TAIL LAMP LENS TO HOUSING GASKET

1948-56, Panel	
11A-13461	pair 3.00
1948-54, F-1, For Round Style Tail Lamp	
40-13461	pair 3.00
1955-56, F-1, For Shield Style Tail Lamp	
B5C-13461	pair 6.00



BLUE DOTS

Chrome Rim with glass Blue Dot Lens	
B-13450-GBD	1 Rim and 1 Dot 5.00





CHROME FORD SCRIPT

For you to install on any Tail Lens

91A-16606 each 15.00



LICENSE PLATE BRACKET

1948-56, Rear License Plate Bracket, Black
A-13406-A each 8.00

1948-56, As Above, Polished Stainless Steel
A-13406-SS each 16.00

1948-52, Front, Unpolished Stainless
7C-5034-SS each 15.00



B-13467

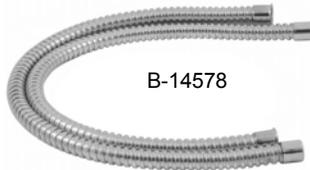

B-14578

TAIL LAMP WIRE SHIELD

Fits backside of Tail Light to protect wires. Die stamped metal

B-13467 Black each 7.50

B-13467-SS Polished Steel each 10.00

Chrome Conduit for Above

B-14578 pair 10.00



LICENSE PLATE FRAMES

1948-56, Please state year desired

13409-S pair 25.00

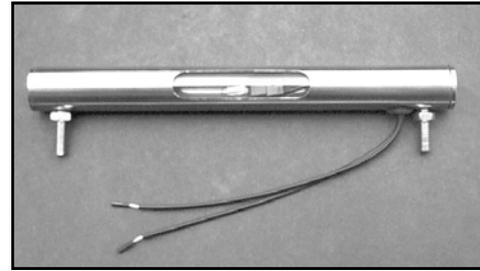

LICENSE PLATE LIGHT

1948-56, License Light, Polished Stainless

HR-13560-SS each 25.00

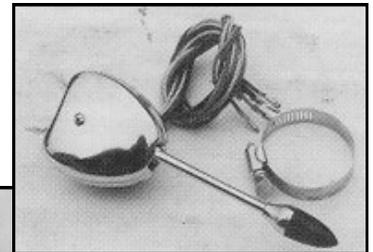

A-13340-TS

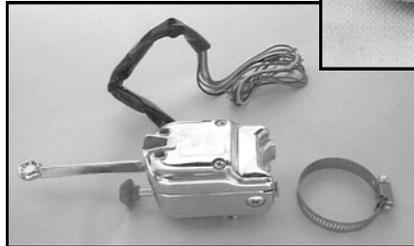

A-13340-HD

UNIVERSAL TURN SIGNAL SWITCH

All Years, Chrome, 12 volt and converts to 6 volt by changing bulb

A-13340-TS each 25.00

As above with 4-way flasher

A-13340-HD each 35.00



TURN SIGNAL FLASHER UNIT

All Years, 6 volt

A-13350-6V each 6.50

All Years, 12 volt

A-13350-12V each 5.00



LIGHT BULBS



HEADLAMP BULB

1948-55, 6 volt B5AF-13007	each	21.00
1948-56, 12 volt B6AF-13007	each	12.00

PARK LAMP LIGHT BULBS

1948-55, F-1, Without Turn Signals B-13466	each	1.00
1956, F-1, 12 volt B6A-13465-A	each	2.00

INSTRUMENT PANEL LIGHT BULBS

1948-55, F-1, 6 volt 78-13466	each	1.75
1956, F-1, 12 volt B6A-13466-A	each	2.00

HIGH BEAM INDICATOR LIGHT BULBS

1948-51, F-1, 6 volt AOAZ-13466-B	each	1.25
1952-55, F-1, 6 volt 78-13466	each	1.75
1956, F-1, 12 volt B6A-13466-B	each	2.00

GLOVE COMPARTMENT LIGHT BULBS

1948-55, F-1, 6 volt 78-13466	each	1.75
1956, F-1, 12 volt B6A-13466-A	each	2.00

TAIL LAMP LIGHT BULBS

1948-55, F-1, 6 volt 11A-13465	each	2.00
1956, F-1, 12 volt B6A-13465-A	each	2.00
1949-56, 6 Volt, Bright Bulbs, 50 Candlepower 11A-13465-6BR	each	4.00
1949-56, 12 Volt, as above 11A-13465-12BR.....	each	4.00



QUARTZ HALOGEN TAIL LIGHT BULB

1948-56, 12 volt, Offset Studs 40-13465-H12	each	6.00
--	------	------



1C-13783

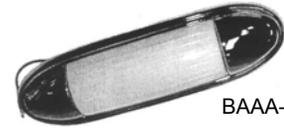

BAAA-13771-SR

DOME LAMP ASSEMBLY

1948-52, Originally for 1951-52 Deluxe Cab—fits all 1948-52 Pickups 1C-13783	each	40.00
1953-56 Pickup, less switch, Chrome, original style. FAA-13786	each	40.00
1953-56 Pickup, Hot Rod Style, without hole for original switch BAAA-13771-SR	each	45.00

DOME LAMP LENS

1951-52, Plastic 81T-13783	each	10.00
1953-56 Pickup 8M-13783	each	7.00



BAAA-13769



8M-13713



40-13740

DOME LAMP SWITCH

1953-56, With Chrome plated knob BAAA-13769	each	14.00
--	------	-------

DOME LAMP SWITCH FOR DOOR POST

1948-56 8M-13713	each	6.00
---------------------------	------	------

DOME LAMP LENS GASKET

1951-52 1C-13876	each	3.00
---------------------------	------	------

DOME LAMP WIRE PIGTAIL

1953-56 FAC-13796-B	each	5.00
------------------------------	------	------

DASH DIMMER SWITCH

1948-52 40-13740	each	13.00
---------------------------	------	-------





HORN RELAY

1948-55, 6 volt		
7RA-13853	each	16.00
1956, 12 volt		
B6A-13853	each	16.00



CIGAR LIGHTER ELEMENT & WELL

1948-56, 6 volt		
11A-15055-A	each	24.00
1956, 12 volt		
B6C-15055-A	each	16.00



1C-15052-A 7C-15052 BAAA-15052

CIGAR LIGHTER KNOBS

1948-50, Black with Red Dot		
7C-15052	each	8.00
1951-52, Black with Red Dot		
1C-15052-A	each	8.00
1953-56, Exactly as original		
BAAA-15052	each	8.00

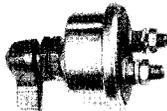

BATTERY DISCONNECT SWITCH

Fits all years, Helps prevent the chance of fire or theft		
A-14300-D	each	25.00



STARTER CABLE BRACKET & GROMMET

1948-56		
48-14550-S	pair	20.00

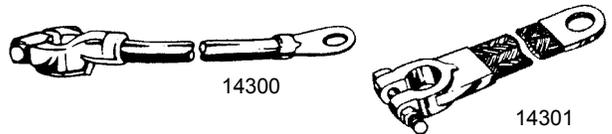

BATTERY CABLES

1948-52, Battery to Solenoid Cable, 17.50" long		
8A-14300	each	21.00
1948-52, Battery Post to Engine Block Cable		
8A-14301	each	19.00

SOLENOID TO STARTER CABLE

1948-56, 48.5" long		
8A-14431	each	22.00



VOLTAGE REDUCER

Reduces 12 volt to 6 volt		
U-10800	each	14.00



VOLTAGE REDUCER

You don't need to change or modify your stock gauges or senders. Install the electronic Voltage Reducer on the back of each gauge. Allows you to use your 6 volt gauges and the rest of the car on 12 volt by reducing the voltage to each gauge. Need one for each gauge.

SR-10606	each	15.00
----------------	------	-------



VOLTAGE REDUCER

1949-55, You don't need to change or modify your stock gauges or senders. Install the electronic Voltage Reducer on the back of the Instrument Cluster. Works on all gauges. Allows you to use your 6 volt gauges and the rest of the car on 12 volt by reducing the voltage to all gauges. Need 1 per car.

D-10800	each	35.00
---------------	------	-------

WIRING

We have many other wires available for 48-56 Trucks.
Also complete wiring kits . . . Call for quote.

Original cloth insulation, color coded
as original with correct terminal ends.
The BEST.

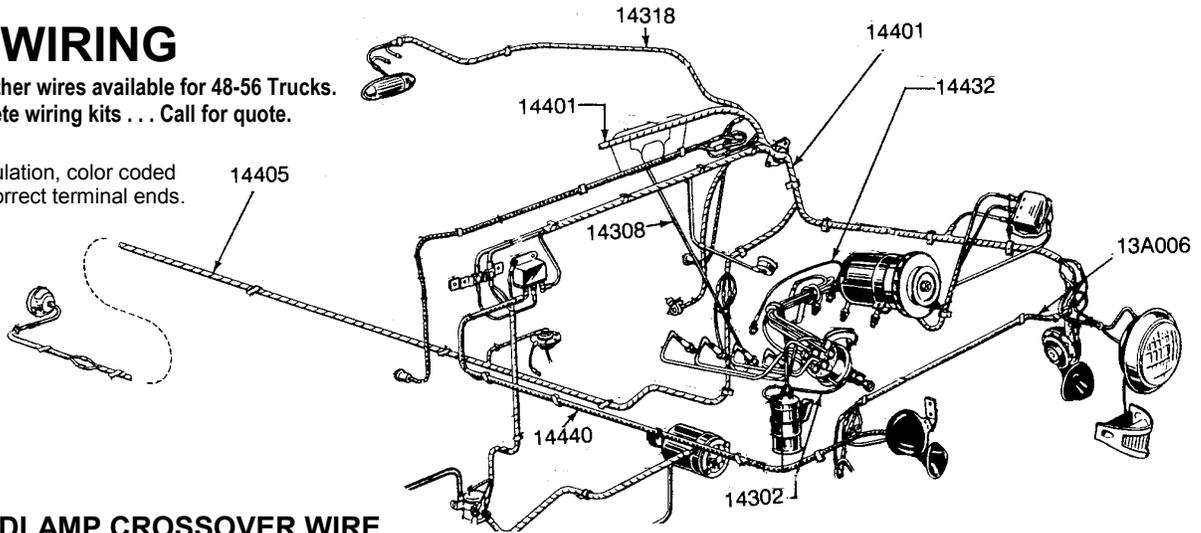

HEADLAMP CROSSOVER WIRE

1948-50		
7HC-11653 each	28.00
1951-52		
1C-11653 each	28.00
1953-55, With turn signal and horn wire		
B4TZ-13A006-A each	38.00
1956, With turn signal switch wire		
B6C-11653-A each	37.00

COWL WIRE LOOM

1948-50, F-1, F-2, 6 cyl., main vehicle Wiring Harness, wires everything under dash through firewall to engine		
8HC-14401 each	333.00
1948-50, F-1, F-2, F-3, V-8		
8RC-14401 each	348.00
1951, F-1, F-2, F-3, V-8		
1RC-14401 each	346.00
1951, F-1, F-2, F-3, 6 cyl.		
1HC-14401 each	403.00
1952, F-1, F-2, F-3, V-8		
2RC-14401 each	348.00
1953, F-1, F-2, F-3, V-8		
FAK-14401 each	331.00
1954, F-1, F-2, F-3, V-8		
FDE-14401 each	325.00
1955, F-100		
B5C-14401 each	367.00
1956, F-1, F-2, F-3, V-8		
B6C-14401 each	261.00

HEADLAMP SOCKET AND WIRE

1948-51		
11A-13076-A each	24.00
1952-55		
B5T-13076-A each	25.00
1956		
B6C-13076-A each	35.00

DOME LIGHT WIRE FEED

1953-55		
B5C-14318 each	37.00
1956		
B6C-14318 each	58.00

OIL SENDER TO COWL WIRE

1948-53		
8RC-14322 each	6.00

TAIL LAMP WIRING

1948-52, F-1, Front of vehicle to Tail Lamp		
8C-14405 each	72.00
1948-52, F-2		
7RD-14405 each	83.00
1953-55, F-1		
BAAA-14405each	83.00
1956, F-1		
B6C-14405 each	59.00

FUEL TANK WIRE

1948-52		
7RC-14406-A each	13.00

WIRING CONT.

TAIL LIGHT CROSSOVER WIRE

1948-52, 43"		
7RC-14424 each	24.00
1953-56		
B5C-14424-A each	21.00

HEAD LAMP SOCKET AND WIRE

1948-55		
11A-13076 each	24.00

COIL TO DISTRIBUTOR WIRE

1948-52, 11" long		
7RA-14302 each	5.00

TEMPERATURE SENDER WIRE

1948-53, F-1, 12" long		
7RA-14432 each	7.00

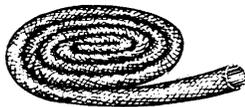

WOVEN WIRING LOOM

Protects wires, holds several in one loom, tough stuff		
B-14407-K 30 ft. roll	15.00

B-14486-S		B-14486-S	
-----------	---	-----------	---

WIRING CONNECTORS

All Years, Single Wiring Connector		
B-14487 pkg. of 10	8.00

All Years, Double Wiring Connector, need 6		
59A-14487 each	2.50

MALE WIRE CONNECTORS

1948-56 All, set of 10		
B-14486-S set of 10	4.00



WIRING CLAMP ON FRAME

B-14585-S pkg. of 10	6.00
-----------	------------------	------



JEWEL TURN INDICATOR LIGHT

1948-52, F-1, Jewel Turn Indicator Light on Dash		
O1C-13583 each	10.00

GROMMETS



MAIN WIRING LOOM GROMMET

1948-56		
1A-14603-B each	4.00

MAIN WIRING LOOM RETAINER

1948-56		
8A-14608 each	10.00

HEADLIGHT WIRE GROMMET

1948-52, Goes on left side of radiator		
8C-13078-C each	4.00

HEADLAMP BUCKET WIRING GROMMET

1948-56		
51A-13077 each	2.00

CHOKE, THROTTLE AND SPEEDOMETER CABLE GROMMET

1948-52		
7C-17265 each	4.00

CHOKE AND THROTTLE CABLE GROMMET

1948-50 and 1953-56		
B-14605 each	2.00

ELECTRIC WIPER MOTOR CABLE GROMMET

1956		
8A-14605 each	2.00

WIPER HOSE GROMMET

1953-56		
BAAA-17545 each	3.00

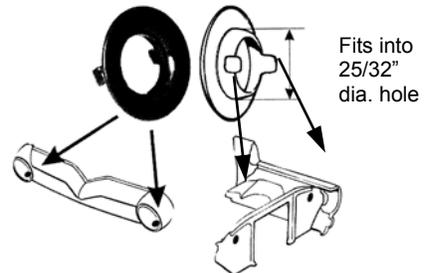

WIRE GROMMET

1948-56, Vinyl coated metal, small 11/16"		
352873-S each	4.00
1948-56, Vinyl coated metal, large 25/32"		
352873-L each	4.00

1948-52

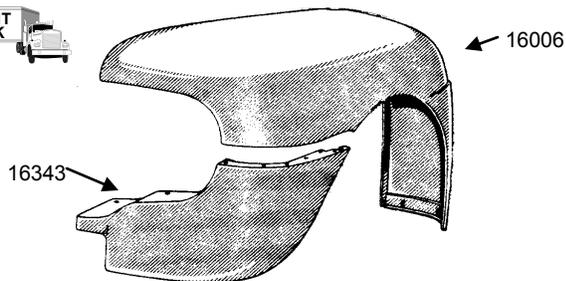

1948-52 FRONT FENDERS

1948-50, F-1, Right Hand, Fiberglass		
7C-16005-FG	each	275.00
1948-50, F-1, Left Hand, Fiberglass		
7C-16006-FG	each	275.00
1951-52, F-1, Right Hand, Fiberglass		
1C-16005-FG	each	275.00
1951-52, F-1, Left Hand, Fiberglass		
1C-16006-FG	each	275.00
1948-50, F-1, Right Hand, Steel		
7C-16005-ST	each	695.00
1948-50, F-1, Left Hand, Steel		
7C-16006-ST	each	695.00
1951-52, F-1, Right Hand, Steel		
1C-16005-ST	each	695.00
1951-52, F-1, Left Hand, Steel		
1C-16006-ST	each	695.00

LOWER FRONT FENDER EXTENSIONS

1948-50, F-1, Right Hand, Fiberglass		
7C-16342-FG	each	85.00
1948-50, F-1, Left Hand, Fiberglass		
7C-16343-FG	each	85.00
1948-50, F-1, Right Hand, Steel		
7C-16342-ST	each	200.00
1948-50, F-1, Left Hand, Steel		
7C-16343-ST	each	200.00
1951-52, F-1, Right Hand, Fiberglass		
1C-16342-FG	each	75.00
1951-52, F-1, Left Hand, Fiberglass		
1C-16343-FG	each	75.00
1951-52, F-1, Right Hand, Steel		
1C-16342-ST	each	200.00
1951-52, F-1, Left Hand, Steel		
1C-16343-ST	each	200.00



1948-50 shown

INNER STEEL FRONT FENDER

1948-50, F1, Right Hand		
7C-16082	each	200.00
1948-50, F1, Left Hand		
7C-16083	each	200.00
1951-52, F1, Right Hand		
1C-16082	each	200.00
1951, F1, Left Hand		
1C-16083	each	200.00
1952, F1, Left Hand		
2C-16083	each	200.00



INNER FENDER APRON BUMPERS

1948-52, Inner Fender Apron to Frame Bumper		
7C-16754-B	pair	4.00

FRONT INNER SPLASH APRON TO FENDER BOLTS

1948-52		
91A-16084	set of 10	10.00
1948-52, As Above, Stainless Steel		
91A-16084-SS	set of 10	20.00

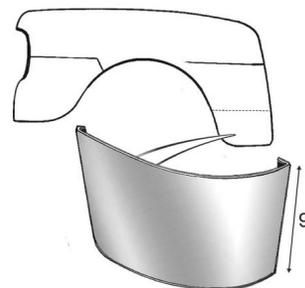

LOWER REAR OF FRONT FENDER REPAIR

1948-52, F-1, Steel, 8" high, specify left or right		
EMS-28	per side	98.00



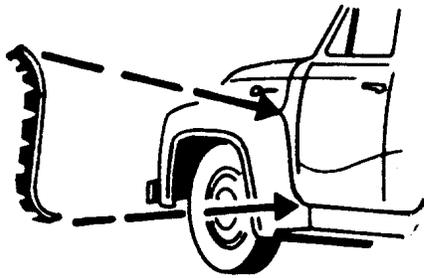

COWL TO FENDER SEAL

1948-52, Fits back of Front Fender to Cowl
 7C-16068 pair 15.00

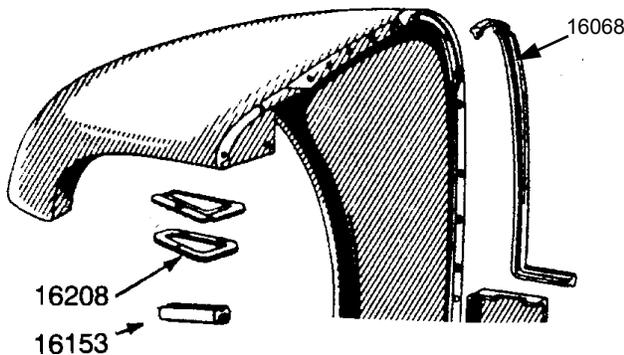

TOP OF FRONT FENDER BRACE TO FENDER SUPPORT RUBBER

1948-52
 7RC-16153-A pair 8.00

FRONT FENDER OPENING FLANGE GASKET

1948-52
 1C-16208 pair 10.00

FRONT FENDER SKIRT FLANGE TO RADIATOR GRILLE GASKET

1948-50
 7C-16086 pair 10.00

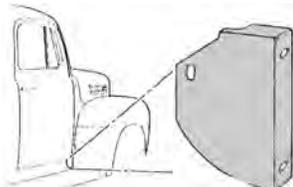

FRONT FENDER EXTENSION

1948-52, F-1, Rear Front Fender Extension. Fills gap between fender and running board
 7C-16040/41-S pair 20.00

1948-52



7C-16312



STEEL REAR FENDERS

1948-Early '50, New Reproduction
 7C-16312/3-ST pair 1300.00
 1948-Early 50, F-1, Right Hand
 7C-16312-ST each 650.00
 1948-Early 50, F-1, Left Hand
 7C-16313-ST each 650.00
 Late 1950-52, New Reproduction
 1C-16312/3-ST pair 1300.00
 Late 1950-52, F-1, Right Hand
 1C-16312-ST each 650.00
 Late 1950-52, F-1, Left Hand
 1C-16313-ST each 650.00

FIBERGLASS REAR FENDERS

1948-Early 50, F-1, Right Hand
 7C-16312-FG each 250.00
 1948-Early 50, F-1, Left Hand
 7C-16313-FG each 250.00
 Late 1950-52, F-1, Right Hand
 1C-16312-FG each 250.00
 Late 1950-52, F-1, Left Hand
 1C-16313-FG each 250.00

REAR FENDER TO BED SIDE BOLTS

1948-56, F-1, Takes 24, as original, 5/16" x 24, 5/8"
 7C-355471-S set of 24 20.00
 1948-56, Bolt, nut and washer kit, Stainless, unpolished
 7C-355471-SS set of 24 30.00
 1948-56, As Above, Polished Stainless
 7C-355471-SSP set of 24 40.00

16340



REAR FENDER BRACE

1948-Early 50, F1
 7C-16340 pair 32.00
 Late 1950-52, F-1
 1C-16340 pair 32.00

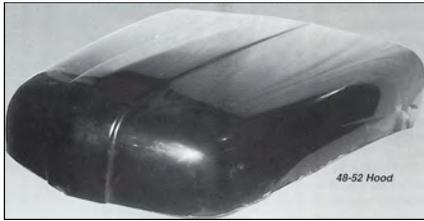

HOOD

1948-52, Fiberglass, smooth
7C-16612-FG each 550.00



2C-16612-FG

1948-50, Hood, Steel As Original
7C-16612-ST each 995.00
1951, As Above
1C-16612-ST each 995.00
1952, As Above
2C-16612-FG each 995.00

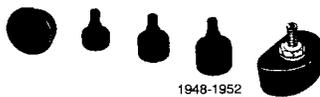

1948-1952

HOOD BUMPER KIT

1948-52, Various rubber bumpers for the hood
7C-16761-S kit 10.00

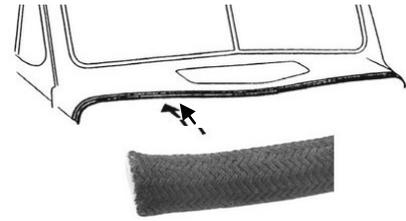

COWL LACING KIT

1948-56, Fits on Cowl at rear of Hood, as original
21C-16740-S kit 15.00
1942-56, Fits on Cowl at rear of Hood, Rubber
B7C-16740 kit 10.00



7C-16802/3-B



7C-16812-SS

HOOD ARM & SPRING SUPPORTS

1948-52, Complete with springs, Right Hand
7C-16802-B each 85.00
1948-52, As Above, Left Hand
7C-16803-B each 85.00
1948-52, Hood Springs, Plain
7C-16812 set of 4 56.00
1948-52, Hood Springs, stainless
7C-16812-SS set of 4 80.00
1948-52, Hood Springs, polished stainless
7C-16812-SSP set of 4 100.00



HOOD HINGES

1948-52, Outer Hood Hinge Side Plate, Left Hand
7C-16797 each 50.00
1948-52, As Above, Right Hand
7C-16796 each 50.00

HOOD HINGE BOLTS

1948-52 4 Bolts & Washers, Stainless Steel
7C-16610-SS kit 2.00

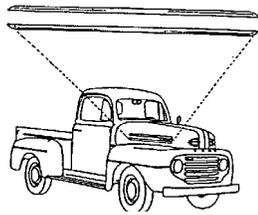

HOOD SIDE MOLDING SET

1948-50, Stainless Steel
 7C-16720 set of 4 100.00



HOOD SIDE EMBLEM

1948-50, Stainless Steel
 7C-16850-PR pair 75.00



7C-16720-CL



7C-16957-CL

HOOD TRIM CLIPS

1948-50, Hood Side Trim Clips, takes 20
 7C-16720-CL each 1.00
 1948-50 and 1951-52 Standard Cab, Hood Side
 Emblem Clips, takes 4
 7C-16850-CL each 1.00
 1948-50, Hood Front Trim Clips, takes 6
 7C-16957-CL each 1.00



SIDE OF CAB EMBLEM—F-1

1948-50, F-1, Die Cast, Chrome Plated
 8C-16605 each 25.00

1948-52

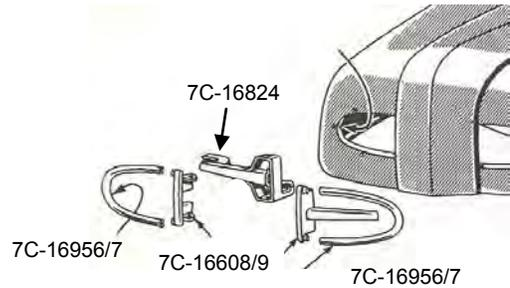

FRONT OF HOOD TRIM MOLDINGS

1948-50, Stainless Steel
 7C-16956/7 pair 45.00

DUMMY HOOD HANDLE

1948-50, Chrome, consists of a LH dummy handle with
 vertical trim and the RH vertical trim
 7C-16608/9 set 75.00

HOOD LATCH HANDLE

1948-50, Hood Latch Handle, Chrome, with mounting
 pin, spring, washers and cotter pin
 7C-16824 set 75.00



7C-16824-kit

HOOD HANDLE KIT

1948-50, Includes 16608/9 & 16824
 7C-16824-KIT kit 150.00



HOOD SIDE ENDS

1951 Deluxe Cab, Die Cast and Chrome Plated
 1C-16732-B pair 120.00



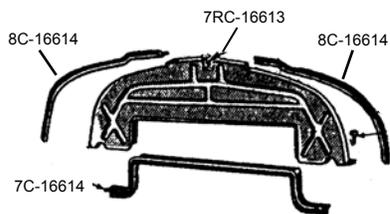

HOOD AIR DEFLECTOR AND SEALS

1948-52, Air Deflector to Radiator Seal		
7C-16614	each	6.00
1948-52, Hood to Air Deflector Seal		
8C-16614	pair	6.00
1948-52, Hood Air Deflector		
7RC-16613	each	60.00



HOOD LOCKING PANEL

1951-52, Stamped Steel		
1C-16848	each	60.00

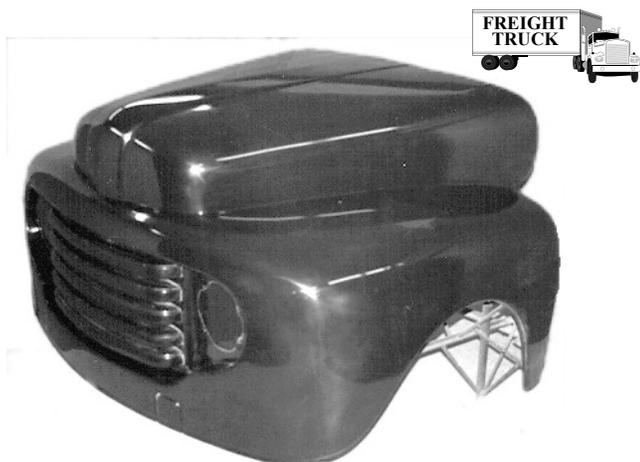

TILT FRONT END ASSEMBLY

1948-50, One piece fiberglass Front End. Crating charge extra, must be shipped freight truck		
8C-16000	each	1485.00
	Crating Charge	200.00

Hinge Kit for Front End above		
8C-16001-K	each	100.00

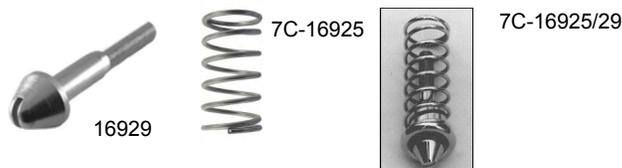

HOOD LATCH, BOLT, SPRING, CUP

1948-50, Guide Pin, F1-F6, Zinc Plated		
7C-16929	each	20.00
1951-52, As Above		
1C-16929	each	20.00
1948-56, Hood Locking Spring only, F1-F6		
7C-16925	each	7.50
1948-52, Bolt, Spring and Cup, Polished Stainless, 3 piece set		
7C-16925/29	set	89.00

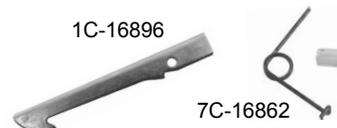

HOOD SAFETY CATCH

1951-52, F1-F6, Hood Safety Catch		
1C-16896	each	15.00
1948-50, F1-F6, Hood Safety Catch Spring		
7C-16862	each	6.50



1951-52, Hood Safety Catch Bracket & Spring Kit, F1, includes bracket, spring, pin, washer & cotter pin.		
1C-16980-KIT	kit	20.00



HOOD LATCH RETURN SPRING

1948-50		
7C-16921	each	10.00
1951-52,		
1C-16921	each	5.00



1953-56

1953-56 FRONT FENDERS

1953-56, F-1, Pickup, Right Hand, Fiberglass BAAA-16005-FG	each	275.00
1953-56, F-1, Pickup, Right Hand, Steel BAAA-16005-A	each	350.00
1953-56, F-1, Pickup, Left Hand, Fiberglass BAAA-16006-FG	each	275.00
1953-56, F-1, Pickup, Left Hand, Steel BAAA-16006-A	each	350.00



FRONT FENDER BRACE

1953-56, Right & Left Hand, plain steel BAAA-16094-PR	pair	25.00
1953-56, Right & Left Hand, Stainless Steel BAAA-16094-PRSS	pair	50.00



BAAA-16748-SS

FENDER ALIGNMENT RODS

1953-56, Polished Stainless BAAA-16748-SS	pair	80.00
--	------	-------



FENDER ALIGNMENT ROD BRACKET

1953-56, Polished Stainless BAAA-16726/27-SS	pair	99.00
---	------	-------



INNER STEEL FRONT FENDER

1953-56, F100-350, Right Hand BAAD-16054-A	each	199.00
1953-56, F100-350, Left Hand BAAD-16055-A	each	199.00



SMOOTH STEEL INNER FENDER

1953-56, F100-350, 18 gauge steel BAAD-16054/5-SM	pair	219.00
--	------	--------

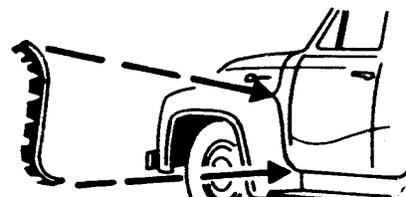

COWL TO FENDER SEAL

1953-56, Fits back of Front Fender to Cowl BAAA-16126	pair	15.00
--	------	-------

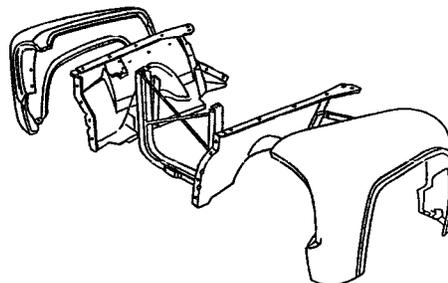

F-100 STAINLESS FRONT END BOLT KIT

1953-56, Complete stainless Bolt Kit for front fenders, inner fender panels, grille valance pan, air deflectors, hood latch pan and rods. Includes all necessary bolts, nuts, flat and lock washers. BAAA-16000-MBSS	kit	55.00
---	-----	-------



1953-56

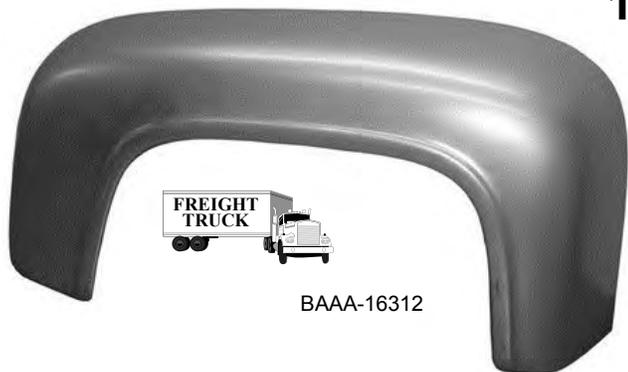

BAAA-16312

STEEL REAR FENDERS

1953-56, F-1, Right Hand, correct steel fenders for flare side bed, Original Ford Dies, USA Made

BAAA-16312-A each 350.00

1953-56, Left Hand, As Above

BAAA-16313-A each 350.00

FIBERGLASS REAR FENDERS

1953-56, F-1, Right Hand

BAAA-16312-FG each 240.00

1953-56, F-1, Left Hand

BAAA-16313-FG each 240.00

REAR FENDER TO BED SIDE BOLTS

1948-56, F-1, Takes 24, as original, 5/16" x 24, 5/8"

7C-355471-S set of 24 20.00

1948-56, Bolt, nut and washer kit, Stainless, unpolished

7C-355471-SS set of 24 30.00

1948-56, As Above, Polished Stainless

7C-355471-SSP set of 24 40.00



There's a good chance we have your parts in stock



FAT REAR FENDERS

1953-56, Fiberglass, Fat Rear Fenders are wider than stock by 3"

BAAA-16312/3-F pair 520.00

16340



REAR FENDER BRACE

1953-56, F-100

BAAA-16340-A each 10.00

1953-56, F-100, with Fat (3" wider) Rear Fenders

PRF-16340-A pair 40.00

B-16070-I



48-16070

BLACK FENDER WELT

B-16070-B, Vinyl 25 ft. roll 12.00

48-16070, Rubber 8 ft. roll 15.00



ANTI-SQUEAK WEBBING

1948-56, F-1, Fits other years also, 1" wide x 50' long

B-17772-C roll 29.00

FREE SHIPPING

Pre-paid orders over \$1,000 are shipped free by UPS ground within the continental US. Free shipping does not apply to back orders, truck freight, UPS oversize (exceeding 48") or overweight (exceeding 70 lbs.).





HOOD

1953-56, Fiberglass, smooth		
B6C-16612-FG	each	625.00
1953-56, Steel		
B6C-16612-A	each	795.00



BAAA-16637-A

BAAA-16638-S

FRONT HOOD EMBLEM

1953-56, Crest Lightening Emblem		
BAAA-16637-A	each	45.00

HOOD EMBLEM PAD

1953-56		
BAAA-16638-S	each	3.00

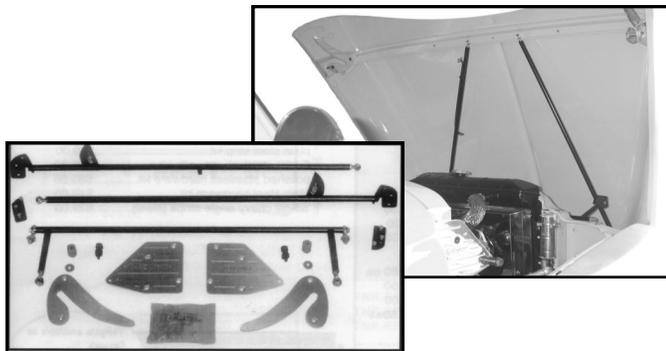

TILT HOOD KIT

1953-56, F-100, Featuring Billet roller mounts and tracks. We use rod ends and bearings for the pivots and adjustments. The hood braces are adjustable and the prop rod is carried on the hood brace and is attached to the core support, easy to install.

FTHK	kit	390.00
------------	-----	--------

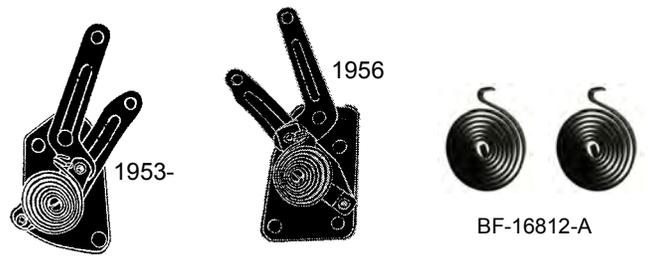

HOOD HINGES

1953-55, Right Hand, complete with springs		
BAAA-16796	each	65.00
1953-55, Left Hand, complete with springs		
BAAA-16797	each	65.00
1956, Right Hand, complete with springs		
B6C-16796	each	65.00
1956, Left Hand, complete with springs		
B6C-16797	each	65.00

HOOD SPRINGS

1953-56, F-1, F-2, F-3, Hood Hinge Springs		
BF-16812-A	pair	40.00



HOOD HINGE SHOULDER BOLTS

1953-55		
8A-16610	each	3.00
1956		
B6C-16610	each	3.00



HOOD LOCKING PANEL

1953-56		
B5C-16717-A	each	175.00



HOOD STABILIZER RODS

1953-56, Polished Stainless		
BAAA-16680-SS	pair	75.00

1953-56

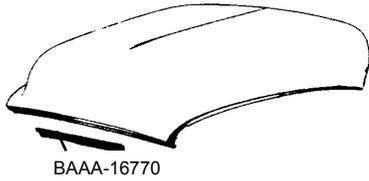

HOOD SEALS

1953-56, Hood Front to Top of Radiator Seal
 BAAA-16770 each 8.00

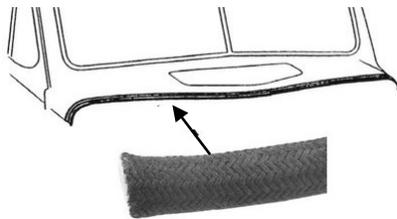

COWL LACING KIT

1948-56, Fits on Cowl at rear of Hood, as original
 21C-16740-S kit 15.00
 1948-56, Fits on Cowl at rear of Hood, Rubber
 B7C-16740 kit 10.00



HOOD BUMPER KIT

1953-56, Includes all necessary hood bumpers
 BAAA-16761-S kit 9.00

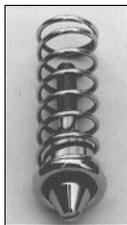

BAAA-16925/29

HOOD LATCH BOLT, SPRING AND CUP

1953-56, Polished Stainless, 3 piece set
 BAAA-16925/29 set 93.00

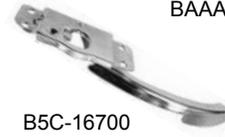

B5C-16700

BAAA-16892-SS



HOOD LATCHES AND PARTS

1953-56 Hood Latch
 B5C-16700 each 35.00
 1953-56, As Above, Stainless Steel
 B5C-16700-SS each 47.00
 1953-56, Latch Return Spring
 BAAA-16921-A each 2.00
 1948-56. Hood Locking Spring only, F1-F6
 7C-16925 each 7.50
 1953-56, Hood Safety Catch Assembly, Stainless Steel
 BAAA-16892-SS each 35.00

7C-16925



HOOD SIDE EMBLEMS



1953-54, Includes boomerang, F-100 emblem & hardware
 BAAA-16732/3-AK set 230.00
 1953-54, Boomerang only
 BAAA-16732/3-AKB pair 200.00



1953-54, F-1, F-100, Chrome
 BAAA-16721 pair 50.00



1955, F-1, Die Cast, Chrome
 B5C-16721-PR pair 75.00



1956, F-1, Right and Left Hand, Chrome, unpainted
 B6C-16721-PR pair 99.00
 1956, F-1, Right and Left Hand, Chrome, painted Red
 B6C-16720-PR pair 99.00

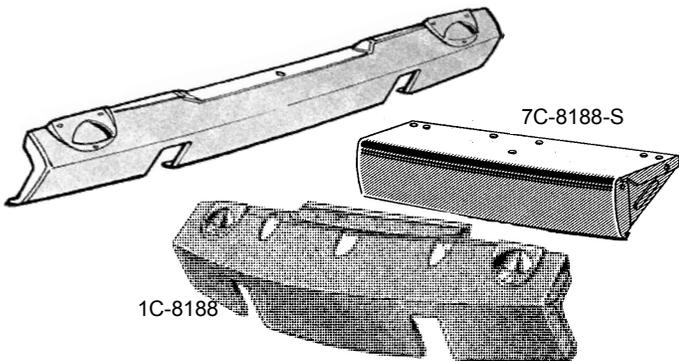

LOWER GRILLE VALANCE

1948-50, Steel		
7C-8188-S	each	175.00
1948-50, Fiberglass		
7C-8188-F	each	75.00
1951-52, Fiberglass		
1C-8188	each	149.00
1951-52, Lower Grille Panel, Steel		
1C-8188-ST	each	225.00
1953, Steel		
B3C-8188-A	each	225.00
1953, Steel, No Bumper Cutouts		
B3C-8188-RLPN	each	225.00
1954, Steel		
B4C-8188-A	each	225.00
1954, Steel, No Bumper Cutouts		
B4C-8188-RLPN	each	225.00
1955-56, Steel		
B6C-8188-A	each	199.00
1955-56, Steel, No Bumper Cutouts		
B5C-8188-RLPN	each	225.00
1955-56, Fiberglass		
B5C-8188-F	each	149.00



LOWER RADIATOR GRILLE SPLASH PAN TO RADIATOR SEAL

1953-56, 23-1/2"		
B3T-8348-A	each	7.00

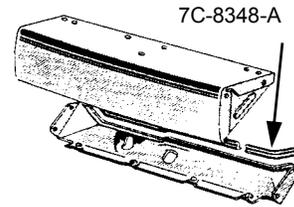

LOWER RADIATOR GRILLE SPLASH PAN TO RADIATOR SEAL

1948-52, 29"		
7C-8348-A	each	4.00
1953-56, 23-1/2"		
B3T-8348-A	each	7.00



UPPER AIR DEFLECTOR TO TOP OF RADIATOR SEAL

1953-56, 27-1/4"		
B3T-8349	each	7.00

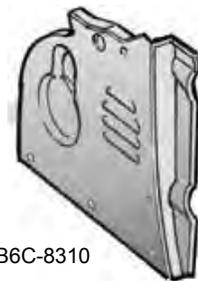

B6C-8310

1C-8310/1

HEADLIGHT SUPPORT PANEL

1951-52, Headlight Support Panels, Die Stamped		
1C-8310/1	pair	95.00
1953-55, Right Hand, Steel		
BAAA-8310-S	each	79.00
1953-55, Left Hand, Steel		
BAAA-8311-S	each	79.00
1956, Right Hand, Steel		
B6C-8310-S	each	79.00
1956, Left Hand, Steel		
B6C-8311-S	each	79.00



1953-56

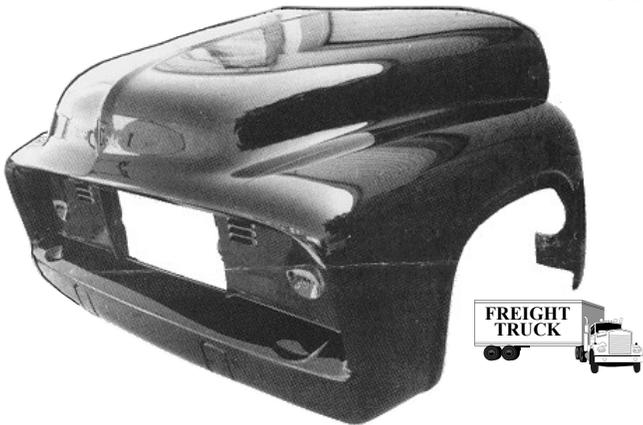

F-100 TILT FRONT END ASSEMBLY

1953-56, As Above
 BAAA-16000 each 1255.00
 Crating Charge 200.00

Hinge Kit for Front End above
 BAAA--16001-K each 55.00



1953-56 FRONT FENDERS

1953-56, F-1, Pickup, Right Hand, Fiberglass
 BAAA-16005-FG each 275.00
 1953-56, F-1, Pickup, Right Hand, Steel
 BAAA-16005-A each 350.00
 1953-56, F-1, Pickup, Left Hand, Fiberglass
 BAAA-16006-FG each 275.00
 1953-56, F-1, Pickup, Left Hand, Steel
 BAAA-16006-A each 350.00



INNER STEEL FRONT FENDER

1953-56, F100-350, Right Hand
 BAAD-16054-A each 199.00
 1953-56, F100-350, Left Hand
 BAAD-16055-A each 199.00



FAT REAR FENDERS

1953-56, Fiberglass, Fat Rear Fenders are wider than stock by 3"
 BAAA-16312/3-F pair 520.00

8C-16400-AS



A-16400-S



RUNNING BOARD STEP PLATE

1948-56, Ford Crest Lightening Emblem, painted
 8C-16400-AS pair 60.00
 1948-52, Ford Oval
 A-16400-S pair 60.00
MOUNTING KIT FOR ABOVE
 A-16400-MBS set 2.50



1948-52 RUNNING BOARDS

1948-52, F-1, Stamped Steel, exactly as original		
8C-16450-S	pair	575.00
1948-52, F-1, As Above, except in Fiberglass		
8C-16450-FGS	pair	300.00

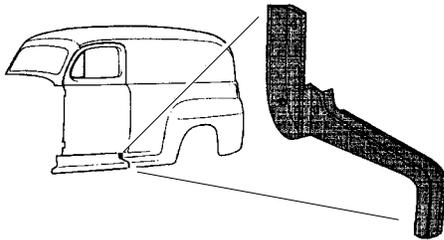

**RUNNING BOARD TO REAR QUARTER
PANEL RUBBER**

1948-52, Panel		
7C-8227838-PR	pair	57.50

**BACK OF FRONT FENDER TO RUNNING
BOARD RUBBER SPACER**

1953-56, 2 of each in kit, with special bolt, nut and lock washer		
BAAA-16460-S	kit	3.00

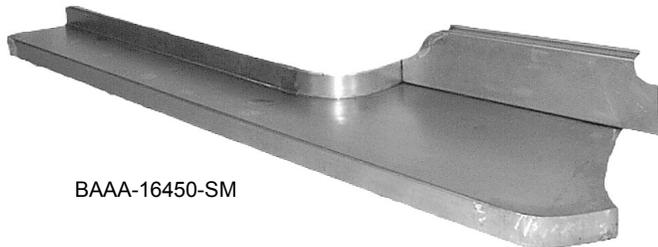

BAAA-16450-SM

SMOOTHIE RUNNING BOARDS

1948-52, F-1, Steel Smoothie Running Boards		
8C-16450-SM	pair	575.00
1953-56, F-100, Steel Smoothie Running Boards		
BAAA-16450-SM	pair	500.00

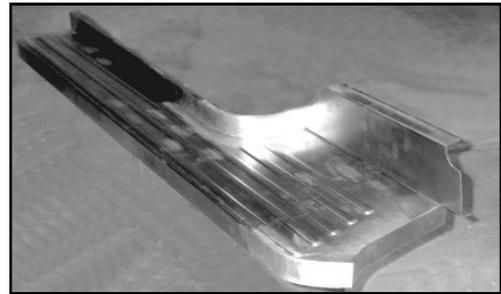

1953-56 RUNNING BOARDS

1953-56, F-100, Stamped Steel, USA		
BAAA-16450/1-B	pair	500.00
1953-56, F-100, Fiberglass Running Boards		
BAAA-16450-FG	pair	310.00

RUNNING BOARD BOLT KIT

1948-52, F-1, 78 pieces		
7C-16455-S	kit	14.00
1953-56, F-1, 56 pieces		
BAAA-16455-S	kit	17.00
1948-52, Stainless Steel, does both boards		
6-0331	kit	19.50
1953-56, Stainless Steel, does both sides, includes bracket bolts, Hex and Hex Nuts		
6-0237	kit	35.00

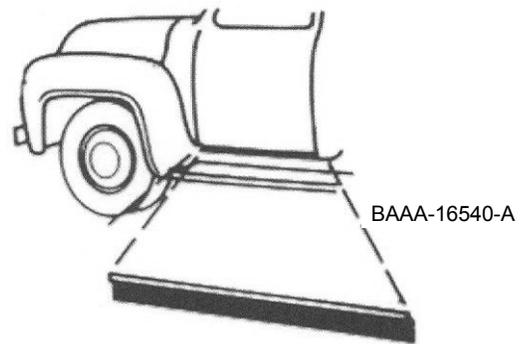

RUNNING BOARD TO BODY SEAL

1953-55, Fits bottom of cab to Running Board		
BAAA-16540-A.....	pair	20.00
1953-56, Panel		
BAAA-16540-C	pair	25.00
1956		
B6C-16540-S	pair	15.00



FORD PICKUP INSTRUMENT BEZEL

1956, F-1, Chrome
56F-9271 each 65.00



FORD PICKUP SPEEDOMETER

1956, F-1
56F-9260 each 159.00



FORD PICKUP FUEL GAUGE

1956, F-1
56F-9262 each 79.00



FORD PICKUP TEMPERATURE GAUGE

1956, F-1
56F-9263 each 79.00



SPEEDOMETER GEAR

1953-56, 20 teeth, blue plastic
B5A-17322-A each 12.00
1953-56, 21 teeth, green plastic
B5A-17322-B each 12.00
1953-56, 19 teeth, brown plastic
B5A-17322-C each 12.00
1953-56, 22 teeth, brown plastic
B5A-17322-D each 12.00



SPEEDOMETER ADAPTER

Adapts GM/Early Ford Thread In Style Cable or Pulse Sensor to Ford C4, C6, and AOD Style Press in Transmission

8C-17260-ADT each 25.00



CODD-17271-B



CIDZ-17292-A

Gear for Adapter above

CODD-17271-B each 10.00

Clip for above

CIDZ-17292-A each 3.00

8C-17260-A



A9A-17260-A

SPEEDOMETER CABLE AND HOUSING

1948-56, F-1, 4 speed and 1948-52, F-1, 3 speed, also fits to GM transmission

8C-17260-A each 20.00

1953-56, F-1, 3 speed, automatic and overdrive, also fits C-4 and C-6 transmissions

A9A-17260-A each 20.00



SPEEDOMETER HOUSING GROMMET

1948-52, F-1, Where it goes through the firewall

7C-17265 each 4.00



SPEEDOMETER TO DASH SEAL

1956, F-1

B6C-17310 each 6.00



WINDSHIELD WIPER PARTS



8C-17470



B6C-17470-A

ELECTRIC WIPER MOTOR CONTROL

1951-52, On-Off Switch		
8C-17470	each	20.00
1953-56, 12 volt		
B6C-17470-A	each	40.00

ELECTRIC WIPER SWITCH NUT

1951-52, Chrome		
7C-17512-B	each	5.50

WIPER SWITCH TO DASH NUT

1953-56		
B7C-17512-A	each	8.50

ELECTRIC WIPER MOTOR CABLE GROMMET

1956		
8A-14605-A	each	2.00

WIPER HOSE GROMMET

1953-56		
BAAA-17545	each	3.00



ELECTRIC WIPER MOTOR & BRACKETS

1948-52, 12 volt, 2 speed, complete with all mounting brackets, pivots, bezels, gaskets, wiring and switch, less arms, blades, and knob.		
8C-17508-12	kit	275.00



BAAA-17508

ELECTRIC WIPER MOTOR

1948-50, 12 volt, 2 speed, complete with wiring, switch and mounting brackets, less knob		
7C-17508	each	175.00
1948-50, As Above, 6 volt		
7C-17508-6V	each	175.00
1951-52, 12 volt, 2 speed, with wiring and switch, replaces Vacuum Motor only, less knob		
1C-17508	each	175.00
1951-52, As Above, 6 volt		
1C-17508-6V	each	175.00
1953-55, 12 volt, 2 speed, complete with wiring, switch and mounting brackets, less knob		
BAAA-17508	each	150.00
1956, As Above		
B6C-17508	each	150.00

WIPER ARM TO MOTOR GROMMET

1948-55		
51A-17562	each	2.00



1C-17513-A

2C-17513-A

BAAA-17513

WINDSHIELD SWITCH KNOB AND NUT

1948-50		
1C-17513-A	each	6.50
1951-52		
2C-17513-A	each	7.00
1953-56, Wiper Knob		
BAAA-17513	each	7.00
1951-52, Electric Wiper Switch Nut, Chrome		
7C-17512-B	each	5.50
1953-56, Electric Wiper Switch to Dash Nut		
B7C-17512-A	each	8.50





356094-S



7C-17515



BAAA-17515-A

WIPER PIVOT SHAFT BEZEL

1948-52		
7C-17515 each	12.00
1953-56		
BAAA-17515-A each	9.00

WIPER PIVOT SHAFT NUT CHROME

1948-55		
356094-S each	6.00
1956		
B6C-356095 each	6.00

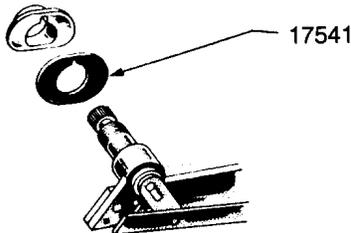

WIPER PIVOT TO BODY GASKET

1948-52		
7C-17541 pair	3.00
1953-56		
BAAA-17541-A pair	3.00



WINDSHIELD WIPER PIVOT REPAIR KIT

1949-51, Knurl Nut Repair Kit		
8A-17566-RKpair	20.00

O6H-17531



WIPER ARM CLIP

1948-56, Goes under dash to motor		
O6H-17531 each	2.00

WIPER HOSE GROMMET

1953-56		
BAAA-17545 each	3.00



WIPER BLADES

1948-52, Original style, Stainless, 10"		
8C-17528 each	16.00
1953-56, Original style		
BAAA-17528 each	16.00



WIPER ARMS

1948-52, Original style, spoon type, fits left or right		
8C-17527 each	16.00
1953-55 and 1956 Left side, Original style, spoon type		
BAAA-17527 each	16.00
1956, Right side, As Above		
B6C-17526 each	16.00



BAAA-17566

B6C-17566

WIPER PIVOT

1951-52, Right Side, Electric Wiper only		
7C-17566-A each	30.00
1951-52, As Above, Left Side		
7C-17567-A each	30.00
1953-55, Fits left or right		
BAAA-17566 each	30.00
1956, As Above		
B6C-17566 each	30.00



WIPER LINKAGE ASSEMBLY

1953-55, Includes pivots, linkage, bezels and nuts		
BAAA-17500 each	160.00
1956, Arm only, need two, fits left or right		
B6C-17500 each	25.00



MIRRORS



On part # 68-17741 you may need to grind some metal off the door hinge in order to use the mirror arm. Grind off just enough for the holes to line up. This applies to 1951-52

DOOR HINGE MIRROR

- 1948-52, Fits right hand or left hand, chrome plated, comes with special pin, 4" head
 68-17741 each 35.00
- 1948-52, As Above with 5" head
 68-17741-5H each 45.00



ROUND MIRROR HEAD ONLY

- 1948-52, Chrome, 4"
 68-17741-MH each 18.00
- 1948-52, Painted Black, 5" diameter
 D1C-17723 each 15.00



RETRO STYLE MIRROR

- All years, Die Cast and Chrome Plated
 SR-18402/3-S pair 80.00

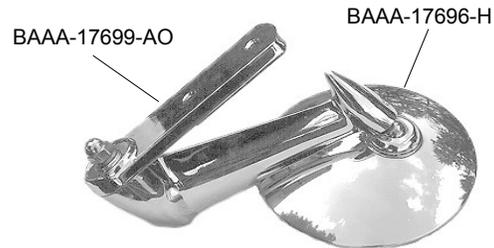

Complete Mirror
 BAAA-17696

OUTSIDE REAR VIEW MIRROR

- 1953-66, Pickup, fits left or right, chrome plated, has all attaching parts including grommet
 BAAA-17696 each 50.00

OUTSIDE REAR VIEW MIRROR ARM

- 1953-66, F-100, Six hole, chrome plated
 BAAA-17699-AO each 20.00

OUTSIDE REAR VIEW MIRROR HEAD

- 1953-66, Ford Script, Triple Chrome Plated
 BAAA-17696-H each 25.00

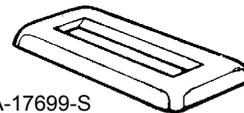

MIRROR POST GROMMET

- 1953-56, Seals around mirror post to door
 BAAA-17699-S each 3.00

DOOR MIRROR HOLE PLUG

- 1953-56, This rubber plug fits into unused door mirror hole slot if you do not run this style mirror.
 BAAA-17699-P each 3.00



OUTSIDE REAR VIEW MIRROR

- 1948-52, Painted Black as original, Right Side
 8C-18402-A each 75.00
- 1948-52, Painted Black as original, Left Side
 8C-18403-A each 75.00





UNIVERSAL DOOR EDGE MIRROR

Left or Right Hand, Chrome, straight arm, 4" head
 A-17741-U each 20.00
 As Above with Convex Glass
 CNX-17741-U each 38.00



3 or 4" PEEP MIRROR

Right or Left Hand, 4" head
 B-18414 each 20.00
 As Above with Convex Glass
 CNX-18414-L/R pair 75.00
 Left or Right Hand, 3" head
 HR-18414 each 20.00



There's a good chance we have your parts in stock

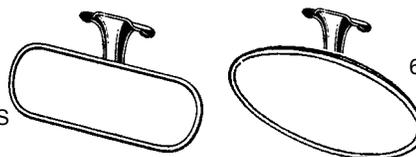

6A-17700-SS

6A-17700-SR

INSIDE REAR VIEW MIRROR

1948-52, Polished Stainless Steel
 6A-17700-SS each 45.00
 1948-52, As Above, Oval Head
 6A-17700-SR each 45.00



INSIDE REAR VIEW MIRROR

1953-56, Rectangular base
 BAAA-17700-B each 45.00
 1956, Triangular base
 B6C-17700-B each 45.00

INSIDE MIRROR BRACKET SCREWS

1948-56, Stainless
 BAAA-17700-MB set of 3 1.00

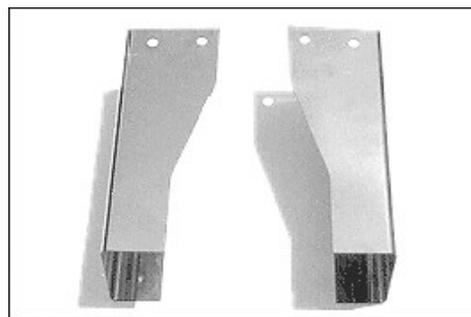

FRAME HORN COVERS

1953-56, Front Frame Horn Covers, polished stainless.
 A finishing addition to a stainless front bumper
 BAAA-17752-SS pair 35.00

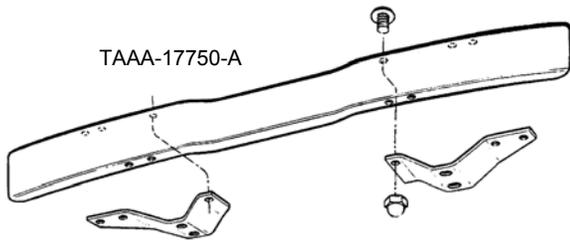

PLAIN FRONT BUMPER

1948-52, F-1, F-100, Plain smooth style with brackets 7RC-17750-A	each	150.00
1953-56, As Above TAAA-17750-A	each	150.00

STAINLESS STEEL FRONT BUMPER

1948-52, F-1, F-100, This is the 1948-50 smooth style, includes polished stainless lower brackets and bolts 7RC-17750-SS	each	335.00
1953-56, F-1, F-100, As Above TAAA-17750-SS	each	325.00

CHROME FRONT BUMPER

1948-52, F-1, F-100, Front, Chrome, less brackets, Smooth style 7RC-17750-CH	each	229.00
1951-52, F-1, Front, Chrome, less brackets, Ribbed style 1C-17750-CH	each	269.00
1953-56, As Above TAAA-17750-CH	each	229.00

FRONT BUMPER BRACKETS

1948-52, Plain 7C-17754-P	set	40.00
1948-52, Stainless Steel 7C-17754-SS	set	60.00
1953-56, Plain TAAA-17754-P	set	40.00
1953-56, Stainless Steel TAAA-17754-SS	set	60.00
1953-56, Chrome TAAA-17754-CH	set	85.00



PLAIN REAR BUMPER

1948-56, F-1, F-100, Rear, Plain BBAA-17906-A	each	110.00
--	------	--------

STAINLESS STEEL REAR BUMPER

1948-56, Rear, F-1, F-100 BBAA-17906-SS	each	325.00
--	------	--------

CHROME REAR BUMPER

1948-56, F-1, F-100, Rear, Chrome, Smooth Style BBAA-17906-CH.....	each	229.00
1951-52 F-1, Rear, Chrome, Ribbed Style 1C-17906-CH	each	249.00

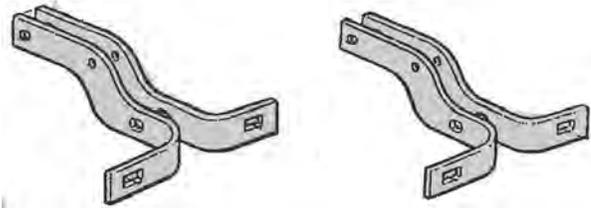

STEEL REAR BUMPER BRACKETS

1948-56, F-1, Set of four B5C-17787/88-S	set	90.00
1948-56, F-1, Chrome, set of four		

"SHORTY" STEEL REAR BUMPER BRACKETS

1948-56, F-1, Set of four, brings bumper closer to body. SB-17787/88-S	set	90.00
---	-----	-------



STAINLESS REAR BUMPER BOLTS

1948-56, F-1, Polished Stainless Bolts BB-17758	set of 4	19.00
1948-56, F-1, With Stainless Covered Heads BB-17758-A	set of 4	14.00



SHOCK ABSORBERS

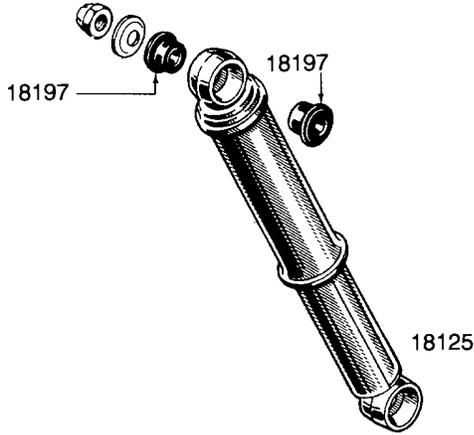

GAS FILLED SHOCK ABSORBERS

1948-52, F-1, F-2, F-3, Front		
8A-18125	each	36.00
1948-55, F-1, F-2, F-3, Rear		
8C-18125	each	36.00
1953-55, F-1, F-2, F-3, Front		
8C-18125	each	36.00
1956, F-1, Front		
8A-18124	each	36.00
1956, F-1, Rear		
B6C-18125	each	40.00

**The Bitterness of Poor Quality
Remains Long After
The Sweetness of Low Price
Is Forgotten**

STORE HOURS:
Mon.-Fri. 8:00-5:00
Sat. 8:30-11:30

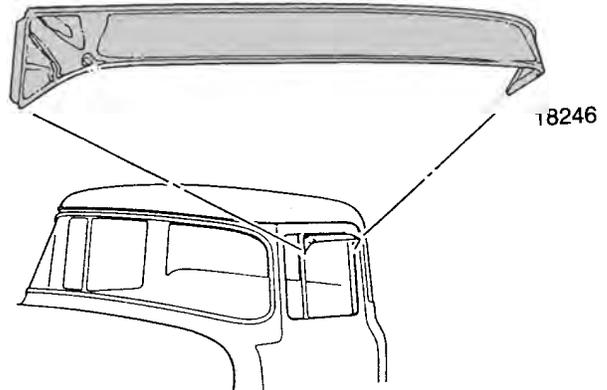

SIDE WINDOW VENT SHADES

1948-52		
7C-18246	pair	50.00
1953-55		
BAAA-18246-S	pair	50.00

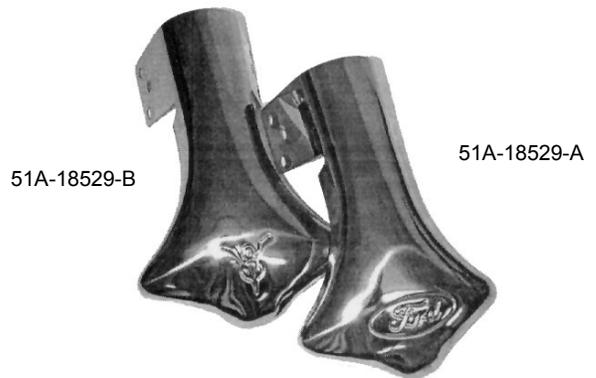

**POLISHED STAINLESS STEEL
EXHAUST DEFLECTORS**

Ford Script		
51A-18259-A	each	18.00
V-8 Exhaust Deflector		
51A-18259-B	each	18.00

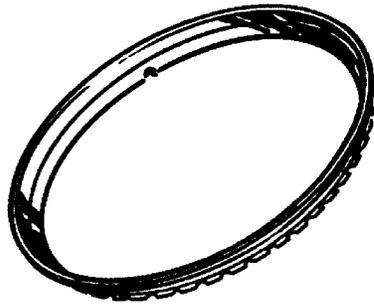

BEAUTY RINGS

15 inch, 4 rib pattern O1A-18303-15	each	29.00
16 inch, 4 rib pattern O1A-18303-16	each	29.00
14 inch, smooth face 6A-18303-14	each	29.00
15 inch, smooth face 6A-18303-15	each	29.00
16 inch, smooth face 6A-18303-16	each	29.00
15 inch, smooth convex 8A-18303-15	each	29.00

ANTENNAS



ACCESSORY RADIO ANTENNA

Mounts on side of Cowl B-18813-U	each	29.00
---	------	-------

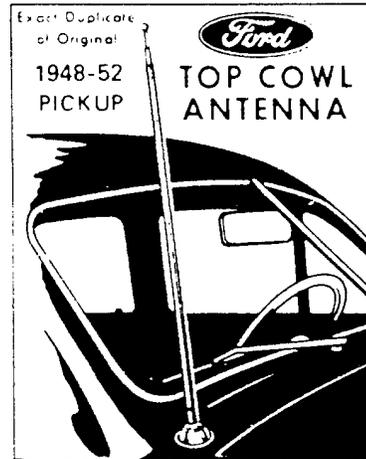

18813

1948-52, Cowl Mount 6A-18813	each	85.00
---------------------------------------	------	-------

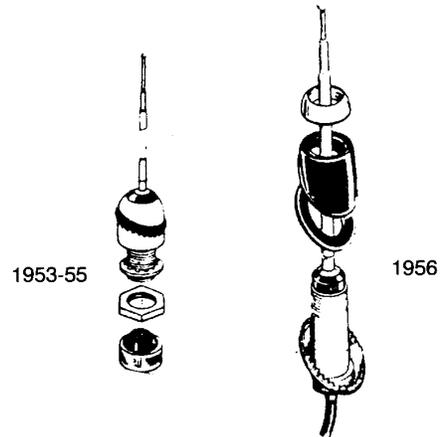

1953-55, Cowl Mount BAAA-18813-A	each	85.00
1956, Cowl Mount B6C-18813	each	85.00

ANTENNA MAST

1948-56 6A-18815-S	each	20.00
-----------------------------	------	-------

HEATER PARTS

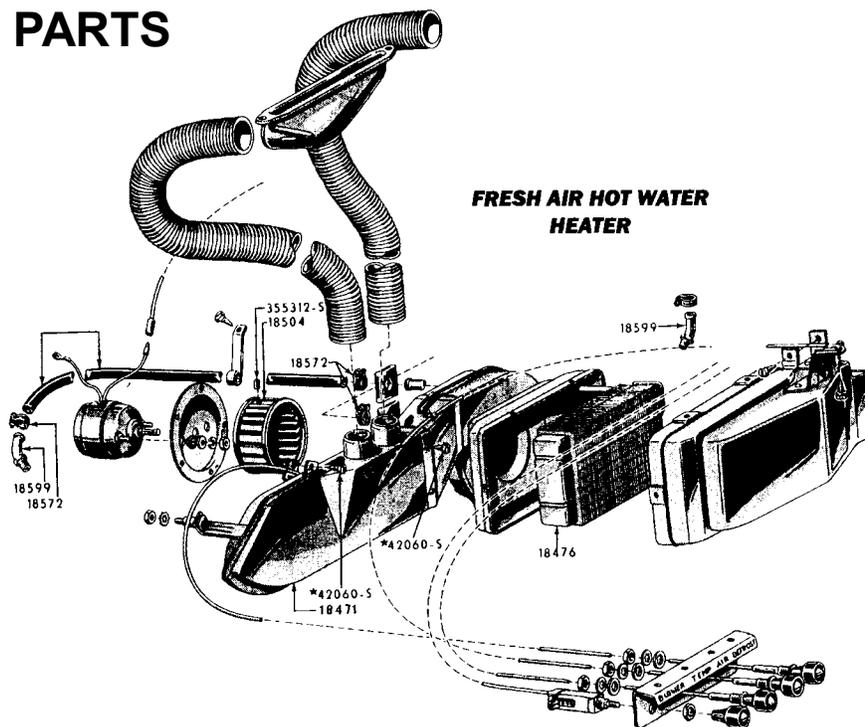

HOT WATER HEATER HOSE

1948-56, F-1, F-2, 5/8" I.D.		
91A-18472-H	per foot	1.50
1948-56, F-1, F-2, 3/4" I.D.		
C9PZ-18472-H	per foot	1.50

HEATER HOSE CLAMP

1948-56, As Original		
BPA-18572-A	each	1.95



HOT WATER HEATER VALVE

1948-56, Screws into engine head		
91A-15142	each	24.00

RECIRCULATING HEATER CABLE SETS

1953-56, Complete with Knobs		
BAAA-18518-R	each	45.00
1956, As Above		
B6C-18518-R	each	45.00

FRESH AIR HEATER CABLE SET

1953-55, Complete with Knobs		
BAAA-18518-F	each	70.00
1956, As Above		
B6C-18518-F	each	70.00



HEATER DEFROSTER NOZZLE GASKET

1948-52, Sponge Rubber, Die Cut, Black		
1C-18547-A	each	15.00

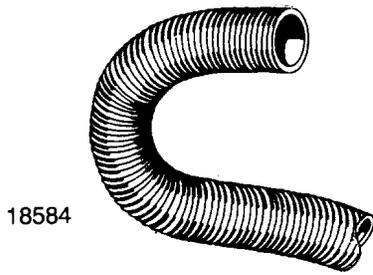

DEFROSTER HOSE

Used as Fresh Air Intake and Air Conditioning Duct Hose on some applications

1948-56, F-1, F-2, all, 1-3/4" I.D. x 6'		
FAA-18584	6 feet	32.00
2" I.D. x 6'		
FAA-18584-2	6 feet	32.00
2-1/2" I.D. x 6'		
FAA-18584-2-1/2"	6 feet	32.00

RECIRCULATING HEATER SEAL KIT

1953-56, Consists of 2 core to housing seals, 1 motor to firewall seal

BAAA-18565-S	kit	15.00
--------------	-----	-------

HEATER HOSE CLAMP

For 5/8" I.D. Hose

BPA-18572-A	each	1.00
-------------	------	------



Call ahead to have your order delivered **FREE** to any of the major swap meets we attend this year. See page 132 for show schedule.

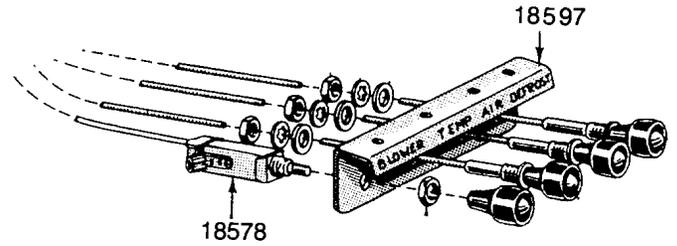

HEATER SWITCH

1948-50		
8C-18578-A	Out of production	
1951-55		
1C-18578	Out of production	
1956		
1A-18578-A	Out of production	

HEATER DEFROSTER BRACKETS

1953-56, Recirculating Air, polished stainless steel, with 2 holes

BAAA-18597-RH	each	35.00
---------------	------	-------

1953-56, Fresh Air, with 4 holes

BAAA-18597-FH	each	35.00
---------------	------	-------

HEATER TUBE TO FIREWALL SEAL

1948-56, Requires 2

8C-18595	each	2.00
----------	------	------

FREE SHIPPING

Pre-paid orders over \$1,000 are shipped free by UPS ground within the continental US. Free shipping does not apply to back orders, truck freight, UPS oversize (exceeding 48") or overweight (exceeding 70 lbs.).





7C-18650



8M-18650

PATENT DATA PLATE

1948-52, Ford, Has blank area for serial number

7C-18650	each	10.00
----------------	------	-------

1948-52, Ford, Stamped with your number

7C-18650-ST	each	25.00
-------------------	------	-------

Mercury, has blank area for serial number

8M-18650	each	10.00
----------------	------	-------

Mercury, Stamped with your number

8M-18650-ST	each	25.00
-------------------	------	-------

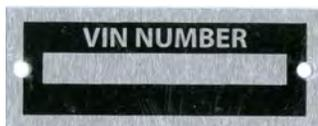

UNIVERSAL VIN PLATE

1948-56		
U-18650	each	10.00
1948-56, Stamped with your number		
U-18650-ST	each	25.00



DATA PLATES

1953-56		
BAAA-18650	each	20.00
1953-56, Stamped, numbers will be stamped from the front instead of from behind as original.		
BAAA-18650-ST	each	100.00

DASH INSULATORS



**UNDER DASH
A B S FIREWALL COVERS**

1948-52, New tough A B S Plastic Firewall Covers with insulation attached. Molded to fit the original firewall with holes pre-cut.

7C-8101670-ABS	each	219.00
1953-55, As Above		
BAAA-8101670-ABS	each	219.00
1956, As Above		
B6C-8101670-ABS	each	219.00

**SPECIAL CLIP TO FASTEN FIREWALL
COVER TO FIREWALL**

1948-52, Takes 13		
48-7001670-C	each	3.00
1953-56, Takes 10		
48-7001670-C	each	3.00

OVERDRIVE CABLE GROMMET

1951-56, F-1		
1A-7001694	each	4.50



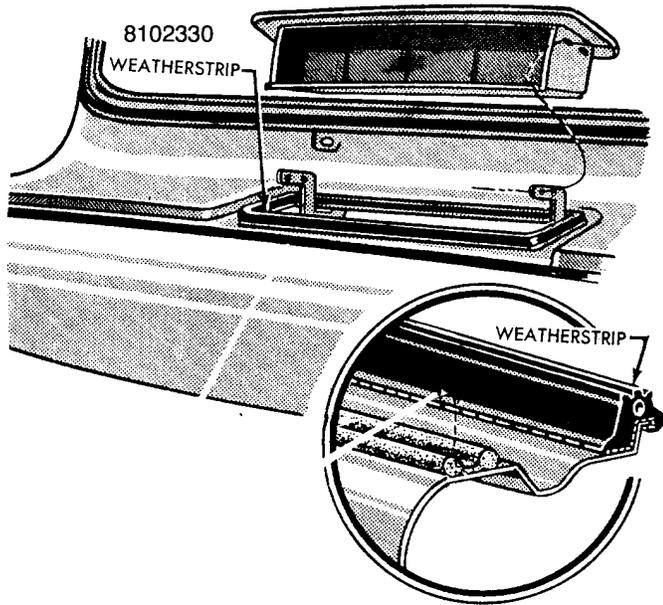

COWL VENT GASKET

1948-52		
7C-8102330-A each	10.00
1953-56		
BAAA-8102330-A each	10.00

COWL VENT KNOB

1953-56		
BAAA-8102145 each	6.50



COWL PATCH PANELS

1953-56		
BAAA-8102054 pair	100.00



**INTERIOR SUN VISOR
LESS ARM AND BRACKET**

1948-52, Black		
7C-8104104-BL each	25.00
1948-52, Brown		
7C-8104104-BR each	25.00
1948-52, Grey		
7C-8104104-GR each	25.00
1953-55, Grey		
BAAA-8104104-GR each	25.00
1953-55, Black		
BAAA-8104104-BL each	25.00
1956, Black		
B6C-8104104-BL each	25.00
1956, Grey		
B6C-8104104-AA each	25.00

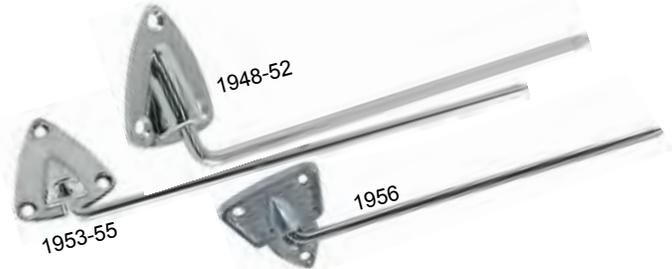

SUN VISOR BRACKET & ARM

1948-52, Plain		
7C-8104144-PP each	17.50
1948-52, Chrome		
7C-8104144-CC each	30.00
1953-55, Plain		
BAAA-8104144-PP each	17.50
1953-55, Chrome		
BAAA-8104144-CC each	30.00
1956, Plain		
B6C-8104144-AP each	17.50
1956, Chrome		
B6C-8104144-C each	30.00

INTERIOR SUN VISOR BRACKET SCREWS

1948-56, Stainless		
BAAA-17700-MB set of 3	1.00

WINDSHIELD RUBBER

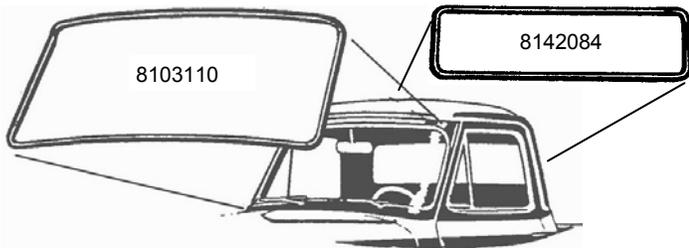

WINDSHIELD RUBBER

1948-52, Without groove for outer molding 7C-8103110	each	40.00
1951-52, Deluxe, where stainless moulding covers windshield rubber 1C-8103110	each	40.00
1953-55 BAAA-8103110-A	each	40.00
1956, For use without outer windshield molding B6C-8103110-A	each	40.00
1956, For use with outer windshield molding B6C-8103110-B	each	40.00

BACK WINDOW RUBBER

1948-50 7C-8142084-A	each	22.50
1951-52 1C-8142084	each	25.00
1953-56, Without wrap around back glass BAAA-8142084-A	each	25.00
1956, With wrap around back glass B6C-8142084-A	each	40.00

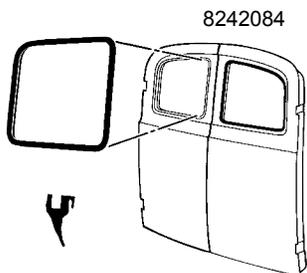

PANEL TRUCK BACK WINDOW RUBBER SEAL

1948-52, Panel, a pair does both doors 7C-8242084-P	pair	60.00
1953-56, Panel, As Above BAAA-8242084-P	pair	60.00



BIG REAR WINDOW CONVERSION PANEL

1953-56 B6C-704280	each	599.00
-----------------------------	------	--------

BIG REAR WINDOW GLASS

1956 B6C-704281	each	299.00
--------------------------	------	--------

BIG REAR WINDOW RUBBER SEAL

1956, with groove for Stainless B6C-8142084-A	each	40.00
1956, without groove for Stainless Molding B6C-8142084-B	each	40.00

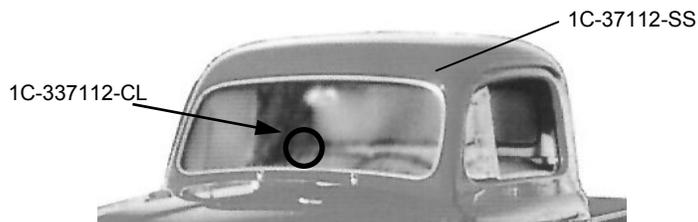

WINDSHIELD TRIM

1948-52, Stainless Steel, with clip 1C-37112-SS	each	125.00
--	------	--------

WINDSHIELD TRIM SEAM CLIP

1951-52, Deluxe Cab, stainless 1C-37112-CL	each	12.00
---	------	-------

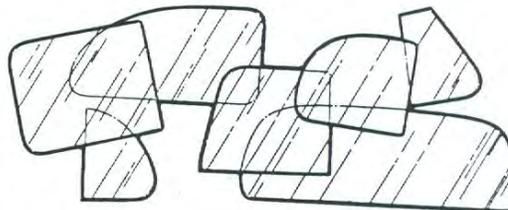

GLASS SETS

Complete Pickup Glass Sets or individual pieces available in Clear, Green, or Smoke Gray. Includes Windshield, Vent, Door and Back Window. Normal shipping in 2-4 business days.

SEE PAGE 129 FOR CURRENT PRICING

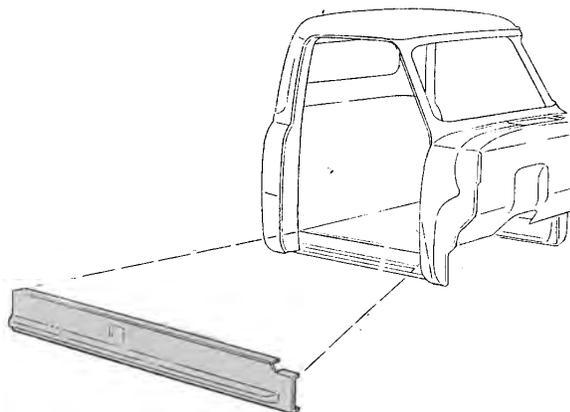

ROCKER PANELS

1953-56, Left Side		
BAAA-8110110-L	each	35.00
1953-56, Right Side		

DECALS

1948-53, Oil Filter Decal, V-8c		
DF-64	each	4.00
1956, Valve Cover Decals, V-8		
DF-70	pair	10.00
1954-56, Oil Filter Decal		
DF-82	each	5.50
1955, Voltage Regulator Decal		
DF-84	each	5.00
1952-54, Voltage Regulator Decal		
DF-109	each	4.00
1948-53, Air Cleaner Decal, Oil Bath		
DF-143	each	3.50
1952-53, Oil Filter Decal Set		
DF-375	set	10.00
1954, Valve Cover Decal, V-8 Power King 130		
DF-642	pair	12.00
1955, Valve Cover Decal, V-8 Power King		
DF-892	pair	12.00
1952-53, Valve Cover Decal, Cost Clipper Six		
DF-1083	each	6.50
1956, Generator Warning Tag		
DF-1125	each	4.00
1949-55, Generator Warning Tag		
DF-1134	each	4.00



GEAR SHIFT BOOT

1948-52, For floor shift, Black		
99A-7242-B	each	16.00



ACCELERATOR PEDAL ROD SEAL

1948-52		
7C-8112177	each	25.00



EMERGENCY BRAKE HANDLE BOOT

1948-52, Pickup, Black		
EB-7000-B	each	5.00

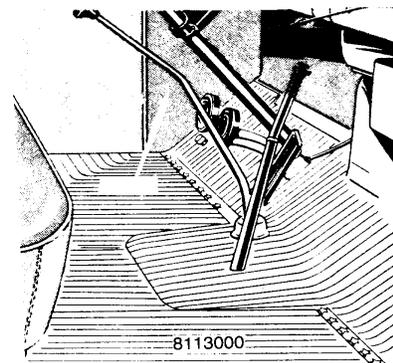

FLOOR MATS

1948-52		
7C-8113000	each	130.00
1948-52 Untrimmed		
7C-8113000-UN	each	120.00
1953-56		
BAAA-8113000	each	95.00



DOOR JAM BUMPERS

1948-52, Takes 2 per door
 B-46440 each 1.50

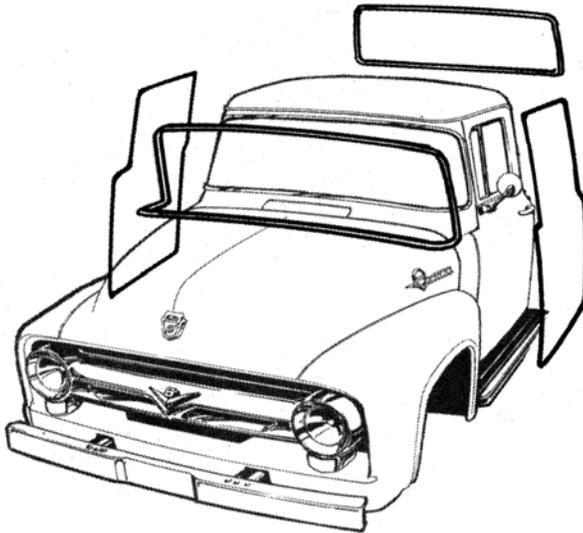

CAB WEATHERSTRIP KITS

Kits include Windshield, Rear Glass and Doors

1948-50, All, without groove for chrome
 7C-WSK kit 100.00

1951-52, All, without groove for chrome
 1C-WSK-A kit 100.00

1951-52, All, with groove for chrome
 1C-WSK-B kit 100.00

1953-55, All, without groove for chrome
 BAAA-WSK kit 100.00

1956, All, without groove for chrome, small back window
 B6C-WSK-A kit 100.00

1956, All, with groove for chrome, small back window
 B6C-WSK-B kit 100.00

1956, All, With groove for chrome, big back window
 B6C-WSK-L kit 115.00

DOOR SEAL SETS

NOTE: Our Door Seals are exact duplicates of the originals. No details are left out. The kit consists of: Front, Top, Back and Bottom of Door Seals. The 1948-52 kit consists of special moulded pieces for the front of door and for lower back side of door. All are bonded into one piece. The 1953-56 kits have the special moulded lower front and rear corners of each door. The 1956 kit also has the special "S" section for area where the door shuts against the windshield frame.

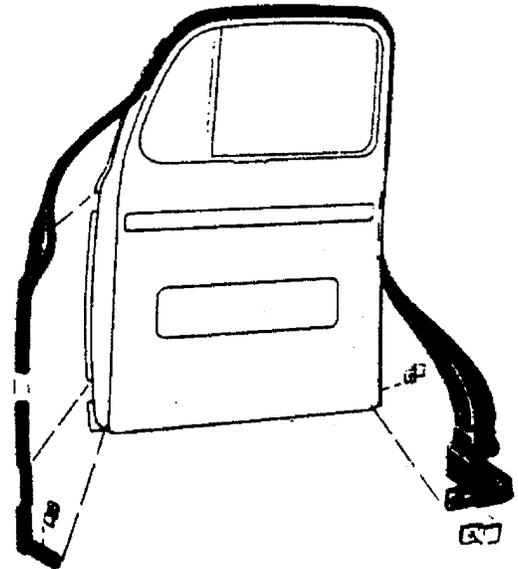

DOOR SEAL KITS

1948-52, For vboth doors, includes Bottom of Door Seals #46-7043725-S
 8C-8120530 kit 60.00

DOOR SEAL CLIPS

1948-52, Includes Clips and Screws, set of 12, does both doors
 8C-8120530-CLIPS kit 6.00

BOTTOM OF DOOR SEAL

1948-52, For both doors, included in kit above
 46-7043725-S pair 8.00

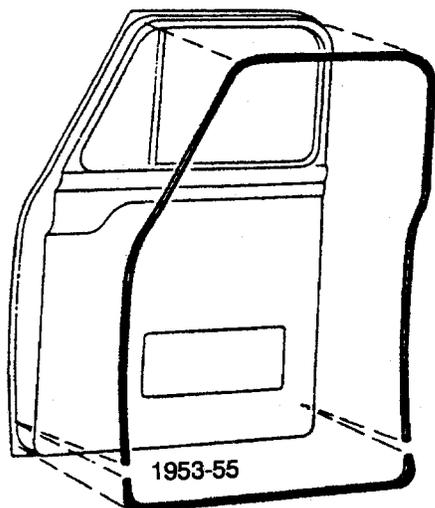

DOOR SEAL SETS

1953-55, For both doors		
BAAA-8120530	kit	60.00
1956, For both doors		
B6C-8120530	kit	70.00

PANEL REAR DOOR SEAL SETS

1948-52, Complete with special molded corners, as original, for both doors		
7C-8243722-PR	set	85.00
1953-56, As Above		
BAAA-8243722/3	set	75.00



DOOR WEATHERSTRIP ADHESIVE

All Years		
915	each	12.00

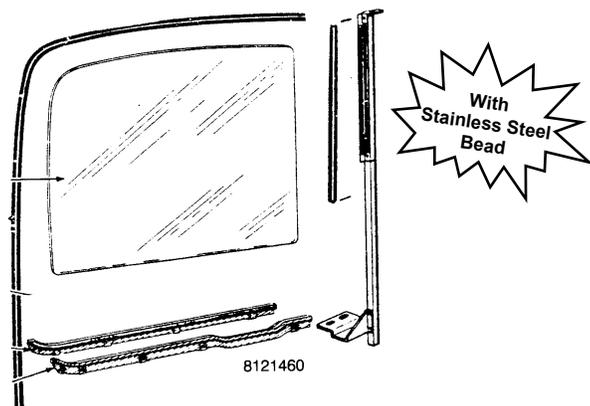

COMPLETE WINDOW ANTI-RATTLER KIT

This is the deluxe kit, has all the felt for above, around, on the side, the U-shape felt, the clips and ready for fast installation. Includes 2 back edge of vent window seals, 2 door glass runs, 4 pieces of window anti-rattler felt and 2 division bar assemblies.

1948-52, With stainless bead, kit does both doors		
7C-8121460-CA	kit	225.00
1948-52, As Above with black bead		
7C-8121460-BB	kit	199.00
1953-55, Kit does both doors		
BAAA-8121460-CA	kit	199.00
1956, Kit does both doors		
B6C-8121460-CA	kit	199.00

CUSTOM GLASS ANTI-RATTLER KIT

Use this kit if you have eliminated your Vent Window

1948-52, With Black BSead, kit does both doors		
7C-8121460-NV	kit	199.00
1953-55, Kit does both doors, Stainless Bead		
BAAA-8121460-NV	kit	199.00
1956, Kit does both doors, Stainless Bead		
B6C-8121460-NV	kit	199.00



WINDOW FELT FASTENING KIT

1948-52, Holds Felt to Body		
48-703536-A	pkg. of 10	6.00

INDIVIDUAL ANTI-RATTLER PARTS

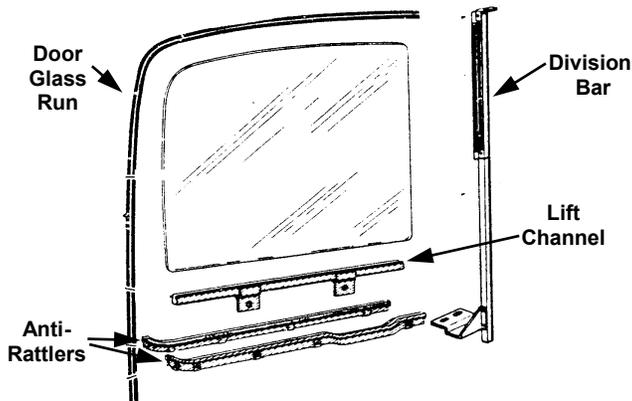

DOOR GLASS RUN

1948-52, Door Glass Run, comes complete with clips installed

7C-8121555	each	35.00
1953-55, As Above, Stainless Edge		
B4C-8121554	each	39.00
1956, As Above, Stainless Edge		
B6C-8121508-A	each	30.00

GLASS ANTI-RATTLERS

1948-52, For both doors		
7C-8121452/3	4 piece set	49.00
1953-55, For one door		
BAAA-8121452/3	pair	30.00
1956, For one door		
B6C-8121452/3	pair	30.00

DIVISION BAR

Complete with all brackets installed ready for installation. Visible area is polished stainless.

1948-52, Right Hand		
7C-8122296-CA	each	60.00
1948-52, Left Hand		
7C-8122297-CA	each	60.00
1953-55, Right Hand		
BAAA-8122296-CA	each	60.00
1953-55, Left Hand		
BAAA-8122297-CA	each	60.00
1956, Right Hand		
B6C-8122296-CA	each	60.00
1956, Left Hand		
B6C-8122297-CA	each	60.00

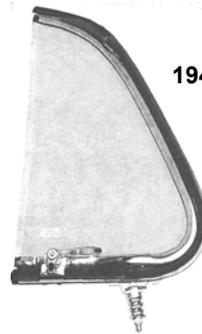

1948-52



1953-55

The Vent Assemblies below are complete, ready to install. Included are inner and outer frames, pivots handles, glass, rubber.

48-50 VENT WINDOW ASSEMBLIES

1948-50 Pickup, Left Hand, Clear Glass		
48F-7021440-LC	each	289.00
1948-50 Pickup, Right Hand, Clear Glass		
48F-7021440-RC	each	289.00
1948-50 Pickup, Left Hand, Tinted Green Glass		
48F-7021440-LT	each	289.00
1948-50 Pickup, Right Hand, Tinted Green Glass		
48F-7021440-RT	each	289.00

51-52 VENT WINDOW ASSEMBLIES

1951-52 Pickup, Left Hand, Clear Glass		
51F-7021440-LC	each	289.00
1951-52 Pickup, Right Hand, Clear Glass		
51F-7021440-RC	each	289.00
1951-52 Pickup, Left Hand, Tinted Green Glass		
51F-7021440-LT	each	289.00
1951-52 Pickup, Right Hand, Tinted Green Glass		
51F-7021440-RT	each	289.00

53-55 VENT WINDOW ASSEMBLIES

1953-55 Pickup, Left Hand, Clear Glass		
53F-7021440-LC	each	289.00
1953-55 Pickup, Right Hand, Clear Glass		
53F-7021440-RC	each	289.00
1953-55 Pickup, Left Hand, Tinted Green Glass		
53F-7021440-LT	each	289.00
1953-55 Pickup, Right Hand, Tinted Green Glass		
53F-7021440-RT	each	289.00



1956 VENT WINDOW ASSEMBLIES

1956 Pickup, Left Hand, Clear Glass		
56F-7021440-LC	each	289.00
1956 Pickup, Right Hand, Clear Glass		
56F-7021440-RC	each	289.00
1956 Pickup, Left Hand, Tinted Green Glass		
56F-7021440-LT	each	289.00
1956 Pickup, Right Hand, Tinted Green Glass		
56F-7021440-RT	each	289.00

VENT WINDOW HANDLES



1948-50



1951-52

1948-50, Right Hand		
78-7022916	each	25.00
1948-50, Left Hand		
78-7022917	each	25.00
1951-52, Right Hand		
8M-7022916	each	25.00
1951-52, Left Hand		
8M-7022917	each	25.00



1953-55



1956

1953-55, Right Hand		
BAAA-7022916	each	25.00
1953-55, Left Hand		
BAAA-7022917	each	25.00
1956, Right Hand, includes button kit		
A9AZ-7022916-A	each	25.00
1956, Left Hand, includes button kit		
A9AZ-7022917-A	each	25.00

VENT WINDOW PARTS

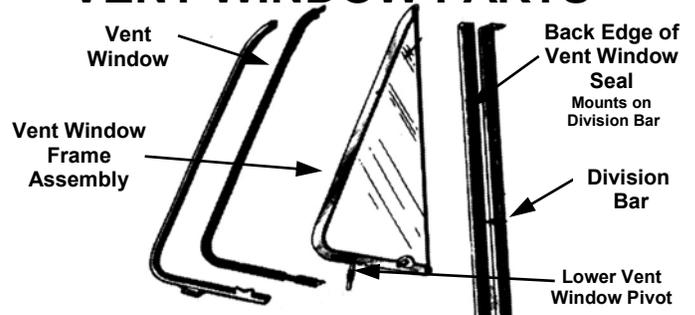

VENT WINDOW RUBBER

1948-52		
7C-8121448/9	pair	65.00
1953-55		
BAAA-8121448/9	pair	65.00
1956		
B6C-8121448/9	pair	65.00

**BACK EDGE OF VENT WINDOW SEAL
(MOUNTS ON DIVISION BAR)**

1948-52, Original style rubber moulded over metal		
7C-8121450-RM	pair	17.50
1953-55, As Above		
BAAA-8121450-RM	pair	17.50
1956, As Above		
B6C-8121450-RM	pair	17.50

VENT WINDOW FRAME ASSEMBLY

1948-52, Left & Right Side, plain steel, less pivots		
7C-8121406/7	pair	110.00
1948-50, Right Side, polished stainless, includes pivots		
7C-8121408-B	each	115.00
1948-50, Left Side, polished stainless, includes pivots		
7C-8121409-B	each	115.00
1951-52, Right Side, polished stainless, includes pivots		
1C-8121408-B	each	115.00
1951-52, Left Side, polished stainless, includes pivots		
1C-8121409-B	each	115.00
1953-55, Left Side, stainless steel with pivots		
BAAA-8121407-B	each	110.00
1953-55, Right Side, stainless steel with pivots		
BAAA-8121406-B	each	110.00

LOWER VENT WINDOW FRAME PIVOT

1953-55, Left Side		
BAAA-8121408-L	each	42.50
1953-55, Right Side		
BAAA-8121409-R	each	42.50

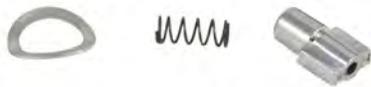

VENT WINDOW HANDLE BUTTON KIT

1951-56, For one handle
 8A-7022920-S kit 6.00



VENT WINDOW BRACKET & HANDLE SHAFT

1948-50
 7C-7022938 each 15.00

1951-55
 O1A-7022938 each 15.00

1956, Right Hand
 8A-7022938-B each 15.00

1956, Left Hand
 8A-7022939-B each 15.00

DOOR WINDOW LIFT CHANNELS

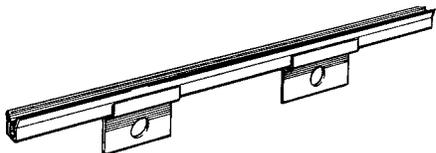

1948-52, Steel Channel that glass sets in, Right or Left
 7C-8121458 each 22.00

1953-55, Right or Left Side
 B5C-8121458-A each 22.00

1956, Right Side
 B6C-8121458-A each 22.00

1956, Left Side
 B6C-8121459-A each 22.00



BA-7023240-A



BA-7023241-A

WINDOW REGULATOR ARM ROLLER

1953-56, F-1, Takes 2 per door
 BA-7023240-A each 6.00

WINDOW REGULATOR ARM TO CHANNEL CLIP

1948-52, Pickup
 BA-7023241-A each 1.00

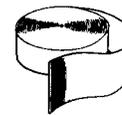

GLASS SETTING TAPE

20' roll x 1" wide, 1/32" thick
 B-37001-A roll 12.00

20' roll x 1" wide, 1/16" thick
 B-37001-B roll 15.00



WINDOW REGULATOR ASSEMBLY

1948-52, Right Side
 7C-8123200-A each 75.00

1948-52, Left Side
 7C-8123201-A each 75.00

1953-55, Right Side
 BAAA-8123200-A each 75.00

1953-55, Left Side
 BAAA-8123201-A each 75.00

1956, Right Side
 B6C-8123200-B each 75.00

1956, Left Side
 B6C-8123201-B each 75.00

BAAA-8123205-S

B6C-8123205-S



WINDOW REGULATOR SHAFT REPAIR KIT

1953-55, To be used when shaft is stripped where window crank handle installs
 BAAA-8123205-S each 15.00

1956, As Above
 B6C-8123205-S each 15.00



DOOR STRIKER PLATE

1948-52, Mounts on door post		
81A-702340	each	10.00
1948-52, As Above, Polished Stainless Steel		
81A-702340-SS	each	12.00
1953-55, Right Hand, Chrome Plated		
BAAA-8122008-A	each	20.00
1953-55, Left Hand, Chrome Plated		
BAAA-8122009-A	each	20.00
1956, Right Hand, Chrome Plated		
B6C-8122008-A	each	20.00
1956, Left Hand, Chrome Plated		
B6C-8122009-A	each	20.00



STRIKER PLATE SHIMS

1953-56		
B6C-8122058-A	each	3.00

STRIKER PLATE BOLTS

1953-56, Phillips Head Bolts		
353382-S	each	1.00

FREE SHIPPING

Pre-paid orders over \$1,000 are shipped free by UPS ground within the continental US. Free shipping does not apply to back orders, truck freight, UPS oversize (exceeding 48") or overweight (exceeding 70 lbs.).



DOOR HINGE ASSEMBLY

1948-52 Upper Left		
7C-8122801	each	55.00
1948-52 Upper Right		
7C-8122800	each	55.00
1948-52 Lower Left		
7C-8122811	each	55.00
1948-52 Lower Right		
7C-8122810	each	55.00
1953-56, F100-350, Upper or Lower, Right Side		
BAAA-8122800-A	each	65.00
1953-55, F100-350, Upper or Lower, Left Side		
BAAA-8122801-A	each	65.00

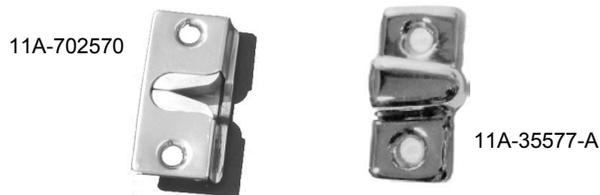

FEMALE DOVETAIL ASSEMBLY

1948-52		
11A-702570	pair	20.00

MALE DOVETAIL

1948-52, Stainless		
11A-35577-A	each	7.00



FEMALE DOVETAIL REPAIR KIT

1948-52, All, Does one door		
11A-702574-RK	kit	7.00

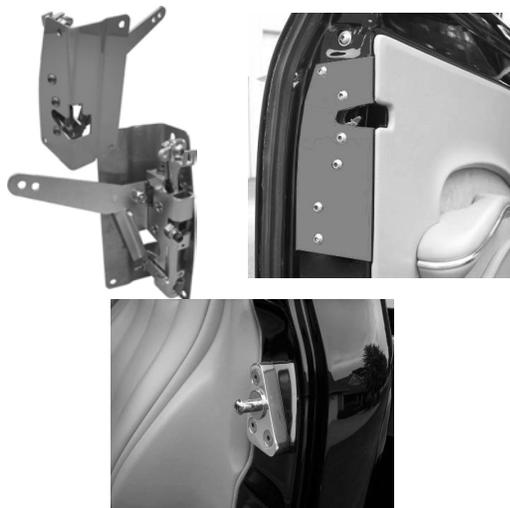

BEAR CLAW LATCH KIT

Direct bolt on Latch Kit. Utilizes original Inside and Outside Door Handles and Lock Assemblies. Includes Latches, Strikers and Hardware.

1948-52, Plain Steel 7C-8121813-ALT-P	kit	349.00
1953-56, Plain Steel BAAA-8121813-ALT-P	kit	250.00



DOOR LATCH ASSEMBLY

1948-50, 1951-52 Standard Cab, Left Side 7C-8121819-A	each	135.00
1948-52, Right Side 7C-8121818-A	each	135.00
1953-55, F100-350, Left Side BAAA-8121813-A	each	80.00
1953-55, F100-350, Right Side BAAA-8121812-A	each	80.00
1956, F100-350, Left Side B6C-8121813-B	each	80.00
1956, F100-350, Right Side B6C-8121812-B	each	80.00

OUTSIDE DOOR HANDLES



OUTSIDE DOOR HANDLE

1948-52, Right Hand, Chrome Plated 7C-8122400-A	each	40.00
1948-52, Left Hand, Chrome Plated 7C-8122401-A	each	40.00
1948-52, As Above, sold in pairs only 7C-8122400/1-PR	pair	80.00
1948-52, Outside Door Handle Pad 7C-8122428	pair	4.00

PANEL TRUCK REAR DOOR HANDLE

1948-56 Panel, rear door outside handle for panel truck 7C-8226600-A	each	50.00
1948-56 Panel, Rear Door Pad BAAA-8222428-B	each	6.00



OUTSIDE DOOR HANDLES

1953-56, Includes Button B5C-8122400/1	pair	75.00
---	------	-------

OUTSIDE DOOR HANDLE PADS

1948-52 7C-8122428	pair	4.00
1948-56 Panel, Rear Door Pad BAAA-8222428-B	each	7.00
1953-56 BAAA-8122428	4 pc. set	6.00

INSIDE DOOR HANDLES & WINDOW CRANKS

1948-52



1948-52, Door Handle
7C-8122614 each 12.00

1948-52, Window Crank
7C-8123342 each 15.00

1953-56

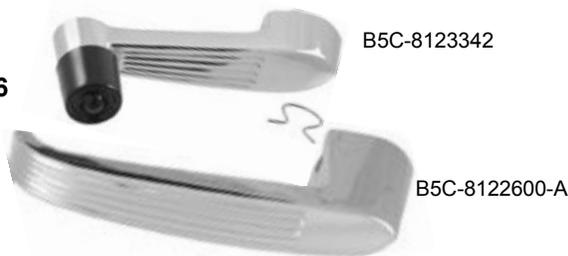

1953-55, Door Handle
B5C-8122600-A each 14.00

1953-55, Window Crank
B5C-8123342 each 15.00

1956

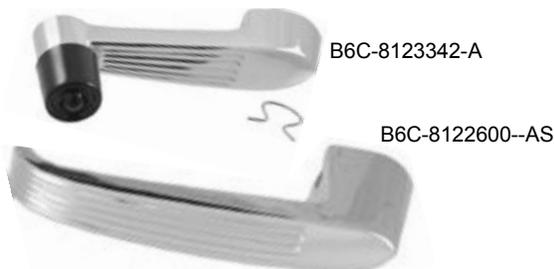

1956, Door Handle
B6C-8122600-AS each 14.00

1956, Window Crank
B6C-8123342-A each 15.00

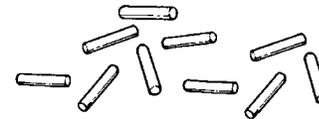

DOOR HANDLE AND WINDOW CRANK FASTENING PINS

1948-52, Steel Pins
01A-46250-P pkg. of 4 1.00



INSIDE DOOR HANDLE RETAINER CLIP

1953-55, Spring Steel
8A-7022601-A each .50



INSIDE ESCUTCHEON PLATES

1948-52 Door Handle and Window Crank
7C-8122618 each 10.00

1951-52 As Above, Deluxe Cab Only
1C-8122618 each 10.00

1953-55
BAAA-8122618



1956
B6C-8122618



INSIDE WINDOW CRANK AND DOOR HANDLE ESCUTCHEON PLATES

1953-55
BAAA-8122618 each 8.00

1956
B6C-8122618 each 10.00



DOOR HANDLE SHAFT REPAIR PARTS

1953-56, Used when shaft is stripped where door handle installs
BAAA-8121818-RK kit 17.50

1953-56, Door Handle Shaft Assembly, Without Arm
BAAA-8121818-R each 40.00

1953-56, Door Handle Shaft Assembly, With Arm
BAAA-8121818-ARM each 45.00



B-702828-S

DOOR CHECK ARM KIT

- 1948-52, Metal Arm with Rubber Bumper, As Original, 7C-702828-PR pair 15.00
- 1948-52, As Above, Replacement type B-702828-S pair 7.50
- 1948-52, Stainless Steel Arm with Rubber Bumper B-702828-SST pair 30.00
- 1948-52, Rubber Bumper only B-46590-A pair 3.00

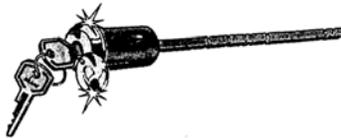

DOOR LOCK ASSEMBLY

- 1948-52, With correct flipper door 21A-702302 each 35.00



51A-7121984

DOOR LOCK CYLINDER WITH KEYS

- 1948-52 51A-7121984 each 18.00
- 1948-52, With matching keys 51A-7121984-PR pair 30.00

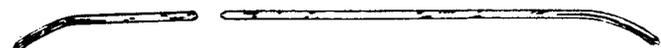
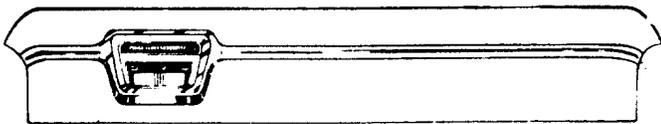

STAINLESS STEEL DASH TRIM

- 1953-55, Custom Cab, 2 pieces for dash, 2 pieces for door, complete with installation clips BAAA-8120960-S set 69.00



IGNITION AND DOOR LOCK CYLINDER AND KEY SET

- 1953-56, Includes ignition and two door lock cylinders with matching keys BAAA-7022050-B set 50.00



87A-7021984-PR



B7C-8122023-A



B4C-8121971-A

DOOR LOCKS WITH KEYS

- 1953-56 B7A-7021984-PR pair 40.00

DOOR LOCK LINK

- 1953-56 B4C-8121971-A each 10.00

DOOR LOCK CYLINDER RETAINER CLIP

- 1953-56 B7C-8122023-A each 5.00

DOOR LOCK OPERATING LEVER RETAINING SPRING

- 1953-56 B7A-7022075-A each 2.50

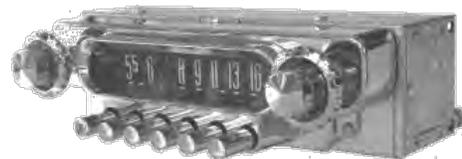

NEW REPRO RADIO

- 1951-52 Pickup and also fits 1949-50 Passenger. 12 volt, AM/FM. Fits dash without modifications, correct knobs and pushbuttons, looks original on outside, but modern on the inside. 1C-8104370-R12 each 687.00





GLOVE BOXES

1948-52		
7C-8106010 each	25.00
1953-55		
BAAA-8106010 each	25.00
1956		
B6C-8106010 each	25.00

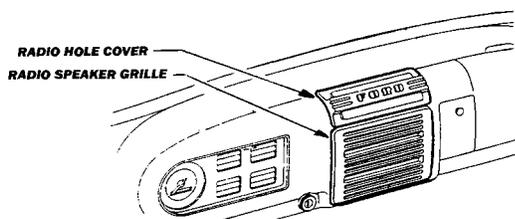

RADIO SPEAKER GRILLE

1948-50, Beige color plastic complete with installation screws		
7C-8104352 each	20.00
1948-50, As Above, Chrome Plated		
7C-8104352-C each	30.00

RADIO HOLE COVER

1948-50, Beige color plastic, complete with mounting hardware.		
7C-8104371 each	15.00
1948-50, As Above, Chrome Plated		
7C-8104371-C each	30.00

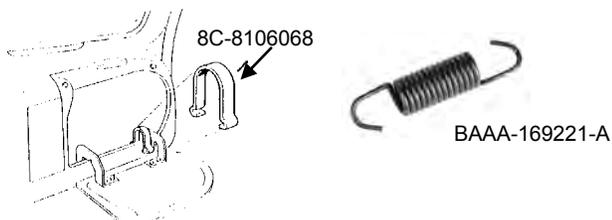

GLOVE BOX DOOR SPRING

1948-52, Glove Box Door Spring		
8C-8106068 each	5.00
1953-56, Glove Box Door Spring		
BAAA-16921-A each	2.00

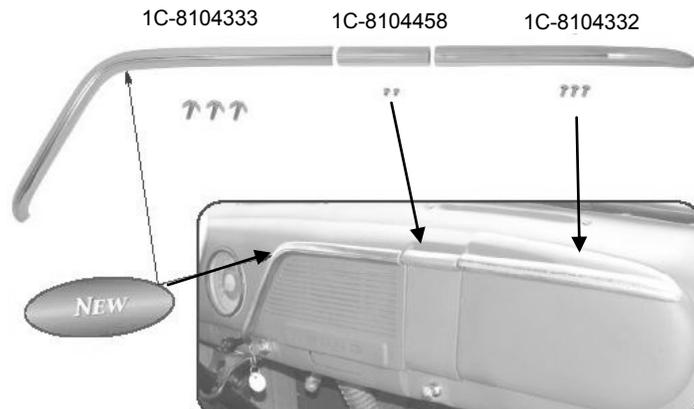

GLOVE BOX DOOR TRIM

1951-52, Chrome		
1C-8104332 each	55.00

ASH TRAY TRIM

1951-52, Chrome		
1C-8104458 each	30.00

SPEAKER TRIM

1951-52, Stainless Steel		
1C-8104333 each	89.00

SPEAKER GRILLE

1951-52, Chrome		
1C-8104405-C each	65.00
1951-52, Black		
1C-8104405-P each	59.00



RADIO HOLE COVER

1951-52, Steel as original, painted Silver with Black letters		
1C-8104371 each	39.00



GLOVE BOX DOOR BUMPERS

1948-52		
1A-7006066 pair	3.00
1953-56		
OA-16378 pair	3.00





1948-52 ROOF HEADLINER KIT

- 1948-52, Pickup, Brown, roof, kick panels, beside back window, below back window
7C-8151968-BR kit 199.00
- 1948-52, Pickup, Black
7C-8151968-BL kit 199.00
- 1948-52, Pickup, Gray
7C-8151968-GR kit 199.00

1953-56 ROOF HEADLINER KIT

- 1953-55, Pickup, Black, Large top center and side strips
B5C-8151968-BL kit 90.00
- 1953-55, Pickup, , Gray
B5C-8151968-AA kit 90.00
- 1953-55, Panel Truck, Gray
B5C-8251968-P kit 120.00
- 1956, Pickup with small back window , Gray
B6C-8151968 kit 90.00
- 1956, As Above, Black
B6C-8151968-BL kit 120.00
- 1956, Panel Truck, Gray
B6C-8251968-P kit 120.00
- 1956, Pickup with large back window, Gray
B6C-8251968-BW kit 120.00

REAR WINDOW TRIM STRIP

- 1953-56 All, 1-1/4" x 45", except '56 big back window, goes under rear window, Gray
BAAA-8140374 each 15.00
- 1953-55, As Above, Black
BAAA-8140374-BL each 15.00

ROOF HEADLINER RUBBER SEAL

- 1953-56, 176" long, holds Headliner in
BAAA-8150956 each 18.50

ROOF HEADLINER CLIP

- 1953-56, Retainer Clip to hold Headliner in, 16 pc. set
BAAA-8150960 set 8.00

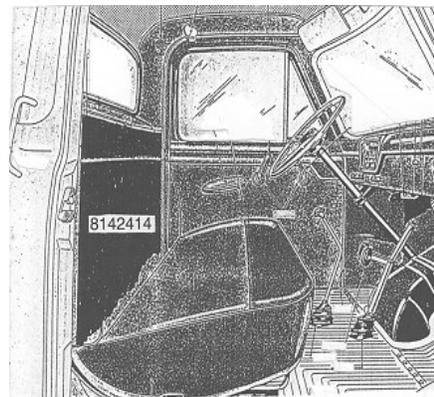

CAB TRIM PANEL (BEHIND SEAT),

- 1953-55, Below back window behind seat, Gray
BAAA-8142414 pair 75.00
- 1953-55 Custom Cab, black, goes under rear window
BAAA-8142414-BL each 75.00



SEAT COVERS

- Pre-sewn Seat Cover Kit, includes: fitted cover, installation hardware
- 1948-52, Black, includes Padding
UCC-4852-BLK kit 199.00
- 1948-52, Gray, As Above
UCC-4852-GRY kit 199.00
- 1948-52, Brown As Above
UCC-4852-BRN kit 199.00
- 1953-55, Call for color
UCC-5355-COLOR kit 199.00
- 1956, Call for color
UCC-1956-COLOR kit 199.00



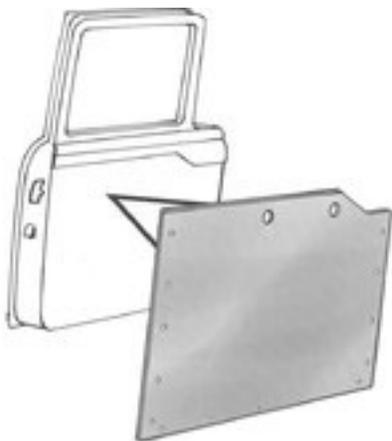

INTERIOR DOOR PANELS

1951-52, Brown, Deluxe Cab		
1C-8123890-BR	pair	25.00
1951-52, Black, Deluxe Cab		
1C-8123890-BL	pair	25.00
1951-52, Gray, Deluxe Cab		
1C-8123890-GR	pair	25.00
1953-55, Pickup, Gray		
BAAA-8123890	pair	50.00
1953-55, Pickup, Black		
BAAA-8123890-BL	pair	50.00
1956, Pickup, Gray		
B6C-8123890	pair	50.00
1956, Pickup, Black		
B6C-8123890-BL	pair	50.00

DOOR PANEL CLIPS

1953-56, For both doors, fastens door panels to doors		
BAAA-8120018	set	10.00



DOOR ARM REST

1948-50, Pickup, has moulded rubber as original. Ready for your upholstery. Kit is for both sides of pickup

8C-8124141-S	pair	60.00
1951-56, Pickup		
BAAA-8124141-S	pair	50.00

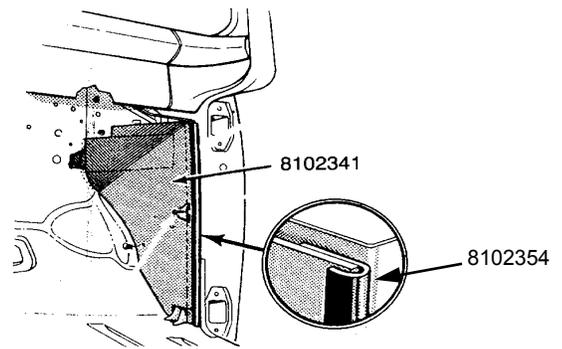

COWL KICK PANELS

1948-52, Brown, fits on each side of truck under dash next to your feet

7C-8102341-BR	pair	25.00
1948-52, Black		
7C-8102341-BL	pair	25.00
1948-52, Grey		
7C-8102341-GR	pair	25.00
1953-55, Grey		
BAAA-8102341-GR	pair	25.00
1956, Grey		
B6C-8102341-GR	pair	25.00

KICK PANEL RETAINERS

1953-55, Polished stainless		
BAAA-8102354-SS	pair	30.00
1956, Polished stainless		
B6C-8102354-SS	pair	30.00

SPECIAL CLIP TO INSTALL KICK PANELS

1948-52, Set of 6		
7C-8102342	set of 6	3.00

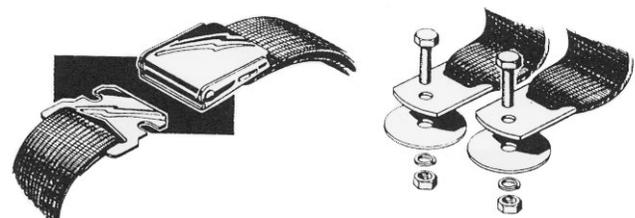

SEAT BELTS

1948-56, Black with chrome buckle, Universal, 75"		
7C-8123100	each	29.00

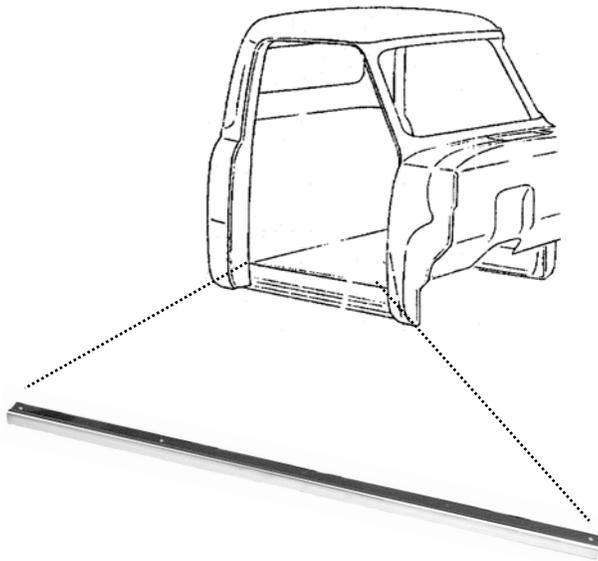

STAINLESS STEEL ROCKER SILLS

1948-56, Polished Stainless Steel. Covers Rocker Sill to give a nice finished look when the door is open
 BAAA-8110111-SS pair 30.00

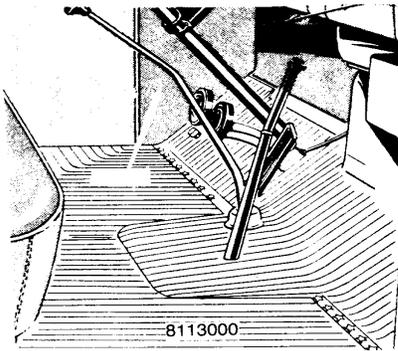

RUBBER FLOOR MATS

1948-52, Black As Original
 7C-8113000 each 130.00
 1948-52 Untrimmed, No holes
 7C-8113000-UN each 120.00
 1953-56, Black
 BAAA-8113000 each 95.00

REGULAR CAB CARPET

1948-52, Vinyl, 80/20
 7C-8113001-CP each 225.00
 1953-56, As Above
 BAAA-8113001-CP each 225.00



OVERDRIVE SCRIPT

1953-56, F-1
 BF-7042528-A each 35.00



CUSTOM CAB DOOR EMBLEM

1955-56
 B5C-8125622-A pair 35.00



DOOR HINGE PINS

1948-52
 1167-B each 1.50
 1948-52, Stainless Steel
 1167-BSS each 3.00
 1948-52, Stainless Steel, **Oversize (.344)**
 B-1167-OSS each 7.00



DOOR HINGE SCREWS

1948-52, Phillips Head, Stainless, with washers
 7C-1166-SS pkg. of 3 3.00

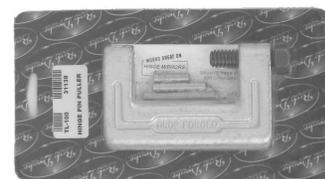

HINGE PIN REMOVER

All Years
 TL-100 each 25.00

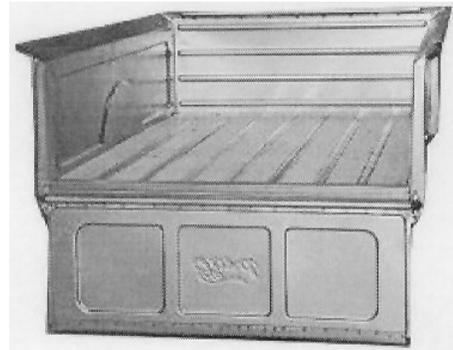

PERIMETER BED

Includes bed sides, front bed panel, rear crossmember.
 Late 1950-52
 1C-830000-PER kit 700.00
 1953-56
 BAAA-830000-PER kit 700.00

COMPLETE BED

1948-Early 1950, Less Tailgate
 8C-830000-UN kit 1945.00
 1948-Early 1950, As Above, Stainless Steel upgrade
 8C-830000-SS kit 2145.00



COMPLETE BED

Late 1950-52, Less Tailgate
 1C-830000-UN kit 1195.00
 Late 1950-52, As Above, Stainless Steel upgrade
 1C-830000-SS kit 1345.00

COMPLETE BED

1953-56, Less Tailgate
 BAAA-830000-UN kit 1195.00
 1953-56, As Above, Stainless Steel upgrade
 BAAA-830000-SS kit 1345.00

TAILGATES

1948-50 Tailgate—21C-8340700 (*Script*) 295.00
 1950-52 Tailgate—1C-8340700 (*Script*) 295.00
 1948-56 Tailgate—B7C-8340700-SM (*Smooth*) 219.00
 1953-56 Tailgate—B7C-8340700-A (*Block Letters*) 375.00

COMPLETE UNASSEMBLED PICKUP BEDS

Due to Ford Licensing requirements Tailgates must be purchased separately

Early Ford's beds are the best money can buy. Laser cut for precision accuracy. Kit includes every part of the bed in kit form, less fenders. Includes: bed sides, front bed panel, red oak bed wood, bed strips, rear cap strip, hidden tailgate latches, tailgate hinges, cross members, complete bolt kit with fender bolts. Stainless Steel upgrade includes: polished stainless bed strips and bolts, polished stainless fender bolts and polished stainless tailgate hinges. Call for freight quote. Approximate shipping weight 500 lbs. Crating charge 1948-Early 1950 **150.00**, Late 1950-56 **100.00**.

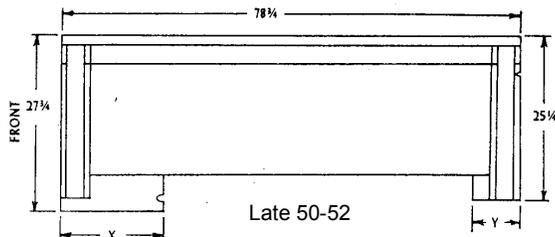
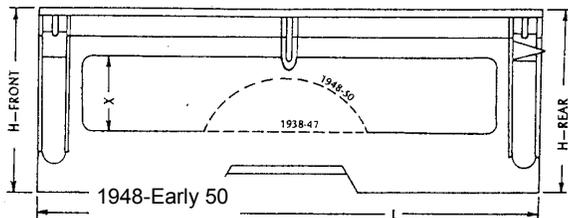

PICKUP BED STEEL SIDE PANELS

1948-Early 50, F-1, Right Hand		
8C-830500	each	425.00
1948-Early 50, F-1, Left Hand		
8C-830501	each	425.00
Late 1950-52, F-1, Right Hand		
1C-830500	each	275.00
Late 1950-52, F-1, Left Hand		
1C-830501	each	275.00
1953-56, F-1, Right Hand, 6 ft. Flare Side Bed		
BAAA-8327840-A	each	275.00
1953-56, F-1, Left Hand, 6 ft. Flare Side Bed		
BAAA-8327841-A	each	275.00
As Above, Right Hand, no fender holes		
BAAA-8327840-SM	each	275.00
As Above, Left Hand, no fender holes		
BAAA-8327841-SM	each	275.00

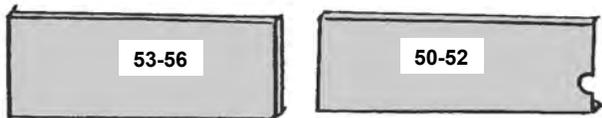

PICKUP BED FILLER PANELS

1953-56, Front Filler Panel		
BAAA-8307842-S	pair	32.00
1950-52, Front Filler Panel		
8C-8307842-S	pair	32.00
1953-56, Rear Filler Panel		
BAAA-8307844-S	pair	22.00
1950-52, Rear Filler Panel		
8C-8307844-S	pair	22.00

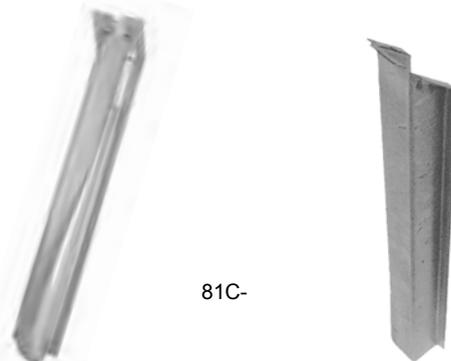

PICKUP BED STAKE POCKET

1948-Early 50, F-1		
81C-830522	each	35.00
Late 1950-56, F-1, Front and rear are the same		
8C-830532	each	30.00



PICKUP BED REAR STAKE POCKET BRACE

1948-Early 50, F-1		
81C-830533	pair	40.00



PICKUP BED SIDE SUPPORTS

1948-Early 50, F-1		
77-830538	each	20.00



PICKUP BED RIVET KIT

1948-Early 50, F-1, This is all the Rivets necessary for you to completely restore your pickup bed		
18-65005-K	kit	25.00

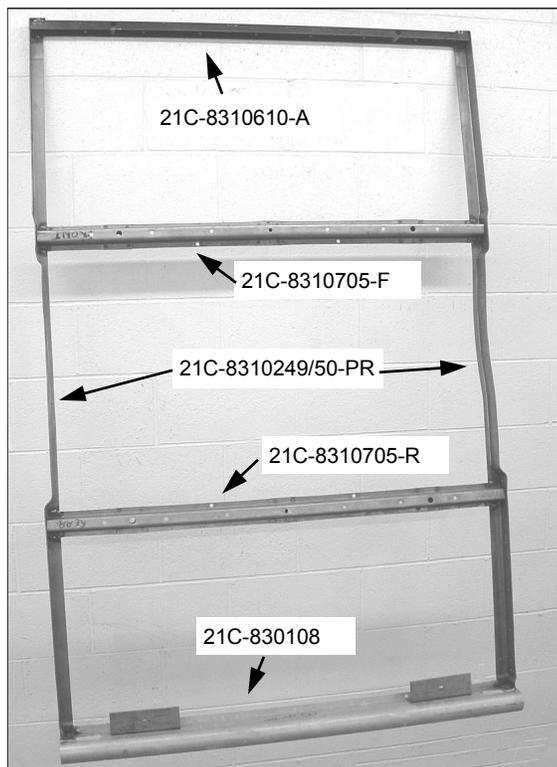

PICKUP BED SIDE SUBRAILS

1948-Early 50, F-1
 21C-8310249/50-PR pair 180.00

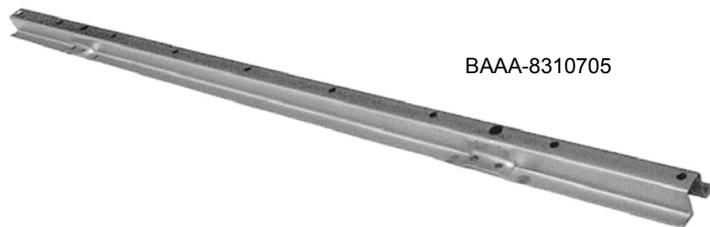

BAAA-8310705

PICKUP BED CENTER CROSSMEMBER

1942-Early 50, F-1, Front Center
 21C-8310705-F each 50.00
 1948-Early 50, F-1, Rear Center
 21C-8310705-R each 50.00
 Late 1950-56, F-1
 BAAA-8310705 each 40.00



BAAA-8310610-A

PICKUP BED FRONT CROSSMEMBER

1942-Early 50, F-1
 21C-8310610-A each 35.00
 Late 1950-52, F-1
 1C-8310610-A each 40.00
 1953-56, F-1
 BAAA-8310610-A each 40.00



BAAA-830108

PICKUP BED REAR CROSSMEMBER

1948-Early 50, F-1
 21C-830108 each 70.00

PICKUP BED REAR CROSSMEMBER

Late 1950-56, F-1
 BAAA-830108-A each 70.00

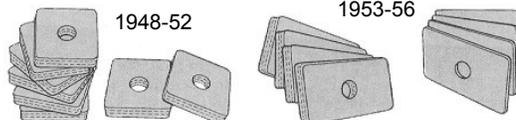

PICKUP BED TO FRAME PADS

1948-52, F-1, Set of 8
 7C-8344155-S set 7.00
 1953-56, F-1, Set of 8
 BAAA-8344155-S set 7.00



1948-50

PICKUP BED FRONT STEEL PANEL

1948-Early 50, F-1
21C-8300124 each 150.00

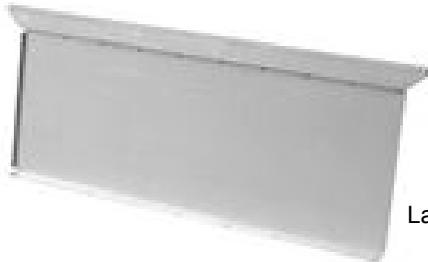

Late 50-56

PICKUP BED FRONT STEEL PANEL

Late 1950-56, F-100, with stock top ends, as original
BAAA-8300124 each 150.00
Late 1950-56, F-100, with pointed top ends
BAAA-8300124-PE each 150.00



65011

TAILGATE HINGES

1948-56, F-1, For Flare Side
81C-65011 pair 15.00
1941-56, As Above, Polished Stainless Steel
81C-65011-SS pair 35.00



F O R D TAILGATE DECALS

1953-56, Step-Side Style, White
DF-689 set 15.00
1953-56, Step-Side Style, Black
DF-690 set 15.00



1950-52

METAL TAILGATE DIE STAMPED

1948-Early 50, F-1
21C-8340700 each 295.00
1946-50 Mercury Tailgate
51M-8340700 each 425.00
Late 1950-52, F-1
1C-8340700 each 295.00



1953-56

1953-56, F-100, For Flare Side Bed
B7C-8340700-A each 375.00
1953-56, As Above, no ears for Tailgate Chains
B7C-8340700-NH..... each 375.00
1953-56, F-250, For Flare Side Bed
B7D-8340700-A each 400.00



MERCURY M-1 TAILGATE

1953-56, No top ears for chains
B7M-8340700-A each 425.00



SMOOTHIE TAILGATE

1948-56, F-1, For Flare Side Bed
B7C-8340700-SM each 225.00

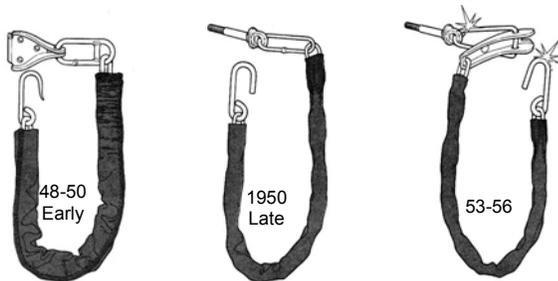

TAILGATE CHAINS AND BRACKETS

1938-50 Early, F-1, Vinyl covers, less bracket		
81C-8344456-A	pair	60.00
1938-50 Early, F-1, As Above, Stainless Steel		
81C-8344456-SS	pair	80.00
Late 1950-52, F-1, rubber covers included		
1C-8344456-A	pair	60.00
Late 1950-52, As Above, Stainless Steel, clear covers		
1C-8344456-SS	pair	80.00
1953-56, F-1, Rubber covers included		
BAAA-8344456-A	pair	80.00
1953-56, As Above, Stainless Steel		
BAAA-8344456-SS	pair	120.00



TAILGATE CHAIN

1948-52, F-1, 13 links		
81C-65008-S	pair	10.00

TAILGATE CHAIN RUBBER COVERS

1948-56, F-1		
7C-8344450-B	pair	10.00

TAILGATE CHAIN RUBBER BUMPERS

1953-56, F-1, F-100, These are the special rubber bumpers that fit in the bracket		
BAAA-8344458-S	pair	5.00

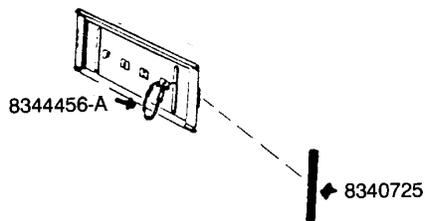

SIDE OF TAILGATE TO BED BUMPER

1953-56, F-1, Goes in Tailgate side		
BAAA-8340725-A	pair	4.00



TAILGATE CHAIN BRACKET

1948-Early 50, F-1		
81C-65006	each	10.00

TAILGATE CHAIN TOP LINK

1948-Early 50, F-1		
81C-65010-S	each	12.00
Late 1950-52, F-1		
1C-65010-S	each	6.00



TAILGATE HOOK

1948-52, F-1		
81C-65007	each	8.00

TAILGATE HOOK RETAINER SPRING

1948-Early 50, F-1		
46-65007-R	each	4.00



TAILGATE CHAIN EYE BOLT

Late 1950-56, F-1		
8C-8344456-B	each	7.50



HIDDEN TAILGATE LATCHES

1948-56, These stainless latches mount on the inside to allow removal of chains and hooks from Tailgate.		
7C-8344457-SS	pair	30.00

TAILGATE STRAPS

1948-56, Nylon straps with stainless buckles, includes all stainless steel hardware kit for installation, 21 inch.		
7C-8344457/58-ST	pair	52.00

TAILGATE LATCH and STRAP KIT

1948-56, Includes Stainless Latches and Nylon strap combined.		
7C-8344457-KIT	KIT	79.00

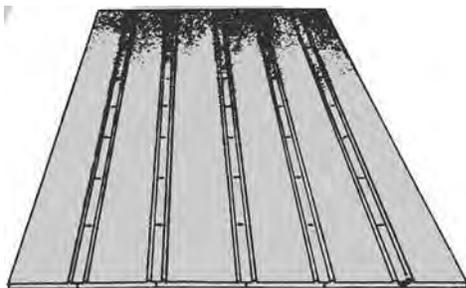

COMPLETE PICKUP BED FLOOR KIT

F1, F100, This complete Floor Kit includes our Oak Floor, Bed Strips, Rear Cap Strip, and Bed Strip Bolt Set.

1948-Early 50, Includes Plain Steel Strips and Cad plated bolts
 21C-8312606-K Kit 375.00

1948-Early 50, As Above, with Polished Stainless Steel Strips and Bolts
 21C-8312606-SSK Kit 499.00

Late 1950-56, Includes Plain Steel Strips and Cad plated bolts
 1C-8312607-PK Kit 375.00

Late 1950-56, As Above, with Polished Stainless Steel Strips and Bolts
 1C-8312607-SSK Kit 499.00



**Amish
 Made**

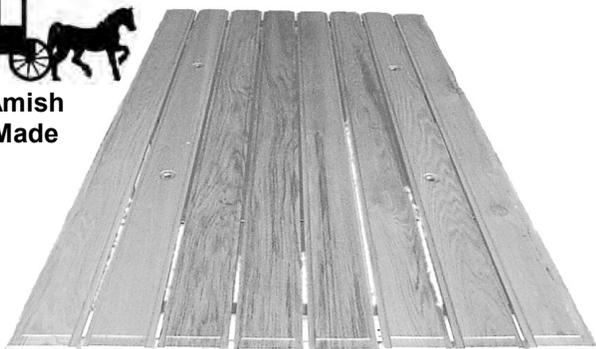

**PICKUP BED FLOOR WOOD
 8 piece set**

Our Bed Wood is made with the finest Red Oak available. All grooves, routing and under-cutting has been done. Available with or without mounting holes.

Late 1950-56, F1, F100
 1C-8312606 **8 piece set** 275.00

1948-Early 50
 21C-8312606 **6 piece set** 290.00



CUSTOM WOOD BED FLOOR

Late 1950-56, F-1, F-100, All grooves, routing and under-cutting has been done. Only available without mounting holes.

1C-8312606--POPLAR	set of 8	160.00
1C-8312606-CURLY MAPLE	set of 8	410.00
1C-8312606-1/4 SAWN OAK	set of 8	375.00
1C-8312606-WALNUT.....	set of 8	445.00
1C-8312606-CHERRY.....	set of 8	325.00
1C-8312606-ZEBRA	set of 8	995.00
1C-8312606-PURPLE HEART	set of 8	595.00
1C-8312606-YELLOW PINE	set of 8	199.00

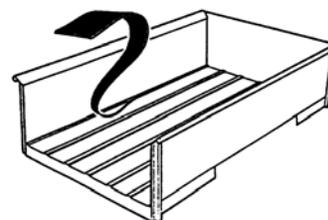

BED SIDE TO WOOD FLOOR SEAL

1948-56, F-1, Rubber
 7C-8344150-S pair 15.00



Call ahead to have your order delivered FREE to any of the major swap meets we attend this year. See page 132 for show schedule.



PICKUP BED STRIPS

1942-Early 50, F-1, Plain Steel, with holes	
21C-8312605-A	each 10.00
1942-Early 50, F-1, Polished Stainless, with holes	
21C-8312605-HSS	each 18.00
Late 1950-56, F-1, Plain Steel, with holes	
1C-8312605-A	each 10.00
Late 1950-56, F-1, Polished Stainless, with holes	
1C-8312605-HSS	each 18.00
Late 1950-56, F-1, Plain Steel	
7C-8312605-A	set of 7 65.00
Late 1950-56, F-1, As Above, Polished Stainless Steel	
7C-8312605-HSS	set of 7 120.00

10 FOOT BED STRIPS

Universal 10 foot bed strips, no holes	
U-8312605-P (Plain Steel)	each 17.00
U-8312605-SS (Polished Stainless)	each 23.00



WOOD SILL COVER FINISH STRIP

This covers the end of wood bed strips at back of bed below tailgate

1948-Early 50, F-1, Polished Stainless Steel	
7C-8312609-SS	each 29.00
Late 1950-56, F-1, Plain Steel	
BAAA-8312609-P	each 15.00
Late 1950-56, F-1, Polished Stainless Steel	
BAAA-8312609-SS	each 29.00



BED STRIP BOLT KITS

1950-56, F-1, Carriage bolt, plain finish, zinc nut and lock washer, kit contains 67 of each plus 21 large flat washers.

7C-8112610-P	kit 40.00
--------------------	-----------

1950-56, F-1, Carriage bolt, polished stainless bolt, zinc plated nuts and lock washers, 67 of each plus 21 large flat washers.

7C-8112610-SS	kit 100.00
---------------------	------------



PICKUP BED HOLD DOWN KITS

Late 50-52 Bed Hold Down Kit, 6 Countersunk Bolts and Washers

8C-1104	kit 30.00
---------------	-----------

Late 50-52, As Above, Stainless Steel, Phillips Head

T-1104	kit 52.00
--------------	-----------

1953-56 Bed Hold Down Kit, 4 Countersunk Bolts and Washers

BAAA-1102	kit 26.00
-----------------	-----------

1953-56, As Above, Stainless Steel, Phillips Head

T-1102	kit 50.00
--------------	-----------



78-1/4\"/>

“WOW” STRIPS AND BOLTS

1948-56, Polished Stainless Steel, sliding “T” bolt type of fastener on the bottom of the strip

7C-8312605-WOW	set of 7 346.00
----------------------	-----------------





STAINLESS BED TO FRAME BOLT KIT

- 1948-52, Polished Stainless Steel, includes bolts, washers, lock washers, nuts
 T-1104 kit 52.00
- 1953-56, Polished Stainless Steel, includes bolts, washers, lock washers, nuts
 T-1102 kit 50.00

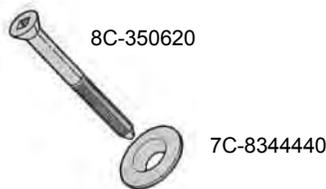

COUNTER SUNK WASHER

- 1948-56, F-1, F-100, cold rolled steel, this is the special washer that goes on top of the wood slat that the bed to frame bolt goes through. 1948-52 takes 6, 1953-56 takes 4
 7C-8344440 each 2.00
- 1948-56, F-1, As Above, Stainless Steel
 7C-8344440-SS each 3.00
- 1948-56, F-1, Bed to Frame Bolt, 1948-52 takes 6, 1953-56 takes 4
 8C-350620 each 3.50



FRONT X-MEMBER BOLT

- 1953-56, F-1, Takes 2 per bed
 8C-350623 each 3.50

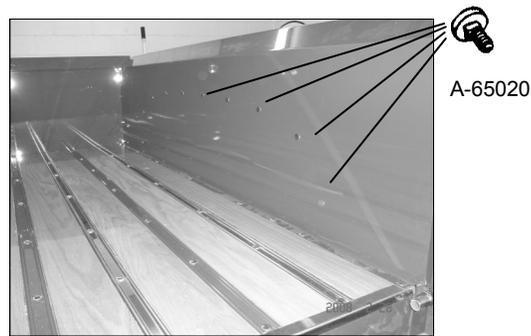

FENDER TO BED BOLTS

- 1948-56
 A-65020 each 1.00

REAR FENDER TO BED SIDE BOLTS

- 1948-56, Takes 24, 5/16" x 24, 5/8"
 7C-355471-S set of 24 20.00
- 1948-56, Bolt, nut and washer kit, Stainless, unpolished
 7C-355471-SS set of 24 30.00
- 1948-56, As Above, Polished Stainless
 7C-355471-SSP set of 24 40.00



PICKUP BED RIVET KIT

- 1948-Early 50, F-1, This is all the Rivets necessary for you to completely restore your pickup bed
 18-65005-K kit 25.00

FREE SHIPPING

Pre-paid orders over \$1,000 are shipped free by UPS ground within the continental US. Free shipping does not apply to back orders, truck freight, UPS oversize (exceeding 48") or overweight (exceeding 70 lbs.).

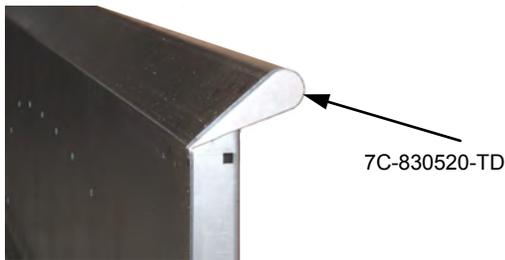

TEARDROPS

1948-56, Designed to cover the rear of the bed roll. Unfinished steel.

7C-830520-TD pair 12.00



HOT LITE'Z FOR PICKUP BED ROLL

1948-56, Sizes available 15/16", 1-1/8", 1-1/4", 1-3/8", 1-5/8". Specify size needed for your bed roll.

7C-830520-LT pair 110.00

1948-56, Aluminum Plugs for bed roll of truck, available in 1-3/8" only.

7C-830520-P pair 40.00

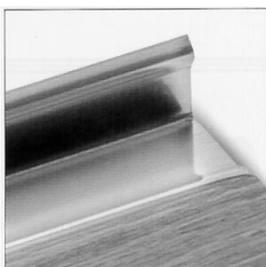

**78-1/4"
Long**

BEDSIDE ANGLE STRIPS

Late 1950-56, F1 and F100, Nice Stainless Steel Strips to finish lower bedside where it meets the bed wood. Holes are pre-punched to bolt into original bedside.

7C-8312608-SS pair 60.00

As Above, Smooth, no holes

7C-8312608-SSM pair 60.00

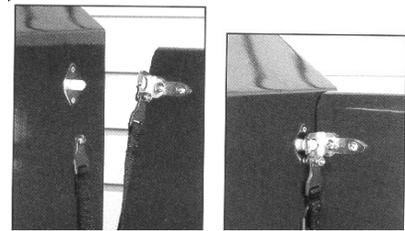

HIDDEN TAILGATE LATCHES

1948-56, Pro's Pick Hidden Tailgate Latches has small stainless steel brackets that attach to the inside of the tailgate, spring loaded catches that install in the bedside (hidden by the stake pocket posts) also made of stainless and nylon, and nylon woven check straps with stainless buckles that hold the tailgate in a horizontal position. The kit includes all fasteners, hardware and complete instructions. Fits any stock or custom tailgate.

7C-8344457-PR pair 185.00



HIDDEN TAILGATE LATCHES

1948-56, These stainless latches mount on the inside to allow removal of chains and hooks from Tailgate.

7C-8344457-SS pair 30.00

TAILGATE STRAPS

1948-56, Nylon straps with stainless buckles, includes all stainless steel hardware kit for installation, 21 inch.

7C-8344457/58-ST pair 52.00

TAILGATE LATCH and STRAP KIT

1948-56, Includes Stainless Latches and Nylon strap combined.

7C-8344457-KIT KIT 79.00

8 FOOT PICKUP BEDS



Shown 1953-56 Less Tailgate, Plain Steel,
 8FT-830000-UNBL kit 1345.00
 As Above, Stainless Steel
 8FT-830000-SSBL kit 1545.00

Shown 1951-52, Less Tailgate, Plain Steel,
 8FT-830000-UNFS kit 1345.00
 As Above, Stainless Steel
 8FT-830000-SSFS kit 1545.00

TAILGATES

1948-52 Tailgate add 295.00 (Ford Script)
 1948-56 Tailgate add 219.00 (Smooth)
 1953-56 Tailgate add 375.00 (Ford Block)

- Dimensions: 49"x 8'. Exactly like an F100 bed, only it has been extended to 8 feet long
- Extra long filler panels
- No fender holes
- Includes Tailgate Hinges, Hidden Latches, and Hardware Kit

- NOT an original reproduction 8 foot bed
- Smooth sides
- Includes F100 bed front, and cross members
- Includes Red Oak Wood
- Bed strips do not have holes

Crate Charge 150.00



8 Foot Perimeter Bed, Includes Sides, Front Panel,
 Rear Crossmember
 8FT-830000-PER kit 875.00

Individual 8 Foot Bed Parts

Pickup Bed Sides, 8 Ft
 8FT-830500-PR pair 700.00
 Pickup Bed Wood, 8 Ft
 8FT-8312606 set 335.00
 Pickup Bed Strips, 8 Ft, Plain Steel
 8FT-8312605-P each 17.00
 Pickup Bed Strips, 8 Ft, Stainless Steel
 8FT-8312605-SS each 23.00

1948-52 F-100 BODY PANELS

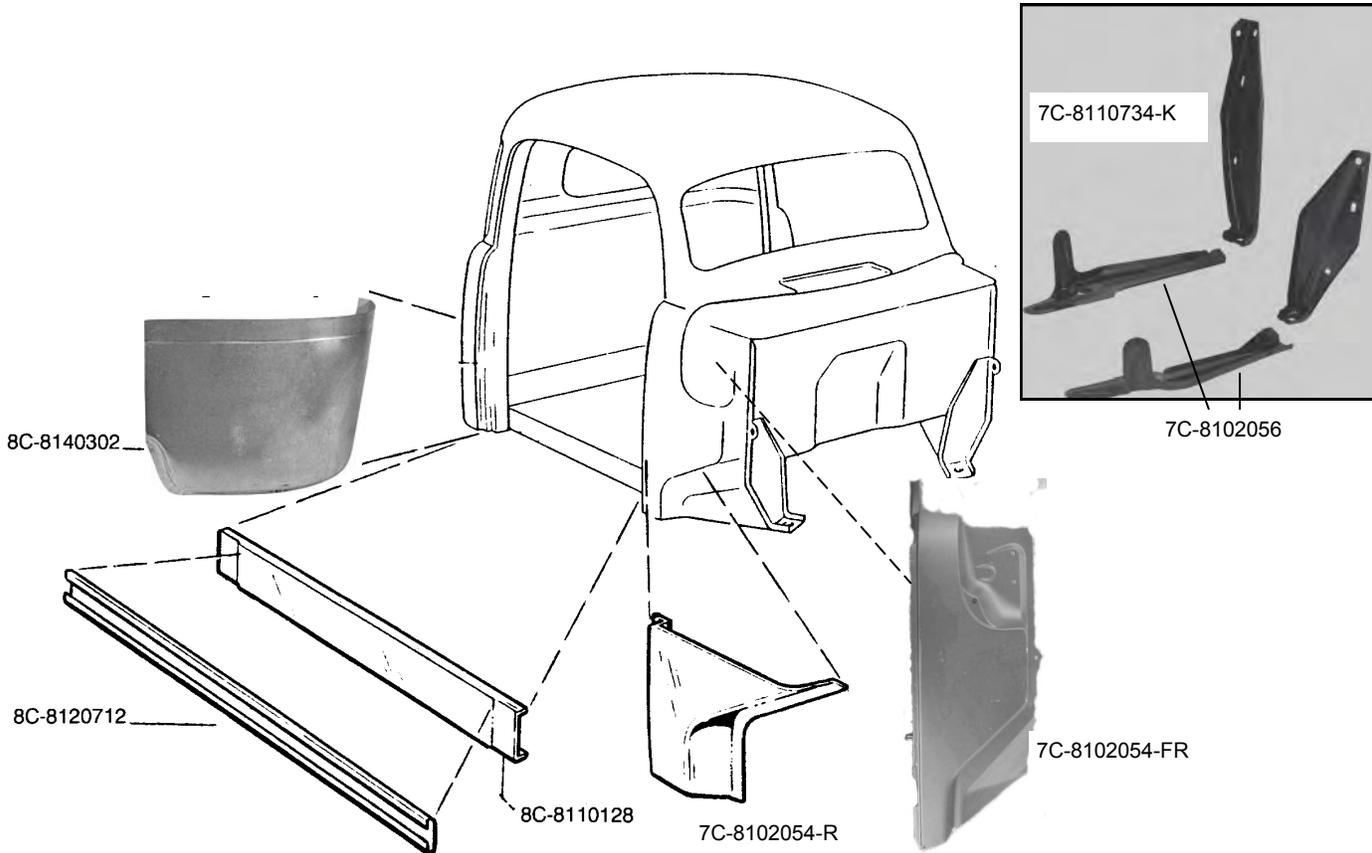

FRONT CAB CORNERS

1948-52, Front Cab Corners, approx. 18" tall

8C-8102054-R Right Side	each	85.00
8C-8102055-L Left Side	each	85.00
8C-8102054-PR	pair	165.00

FULL COWL PANELS

1948-52, Inner and Outer

7C-8102054-FR Right Side	each	145.00
7C-8102055-FL Left Side	each	145.00

REAR CAB CORNERS

1948-52, Rear Cab Corners, die stamped

8C-8140302-R Right Side	each	85.00
8C-8140303-L Left Side	each	85.00
8C-8140302-PR	pair	165.00

FIREWALL SUPPORT BRACKETS

1948-52, 4 pc. Kit, includes lower Cab Mounts

7C-8110734-K	kit	80.00
--------------------	-----	-------

CAB MOUNTS

1948-52, Lower Cab Mounts only

7C-8102056	pair	75.00
------------------	------	-------

ROCKER PANELS

1948-52, Rocker Panels

8C-8110128-S	pair	45.00
--------------------	------	-------

LOWER DOOR SEAL RETAINER

1948-52, Lower Door Seal Retainer

8C-8120712	pair	12.00
------------------	------	-------

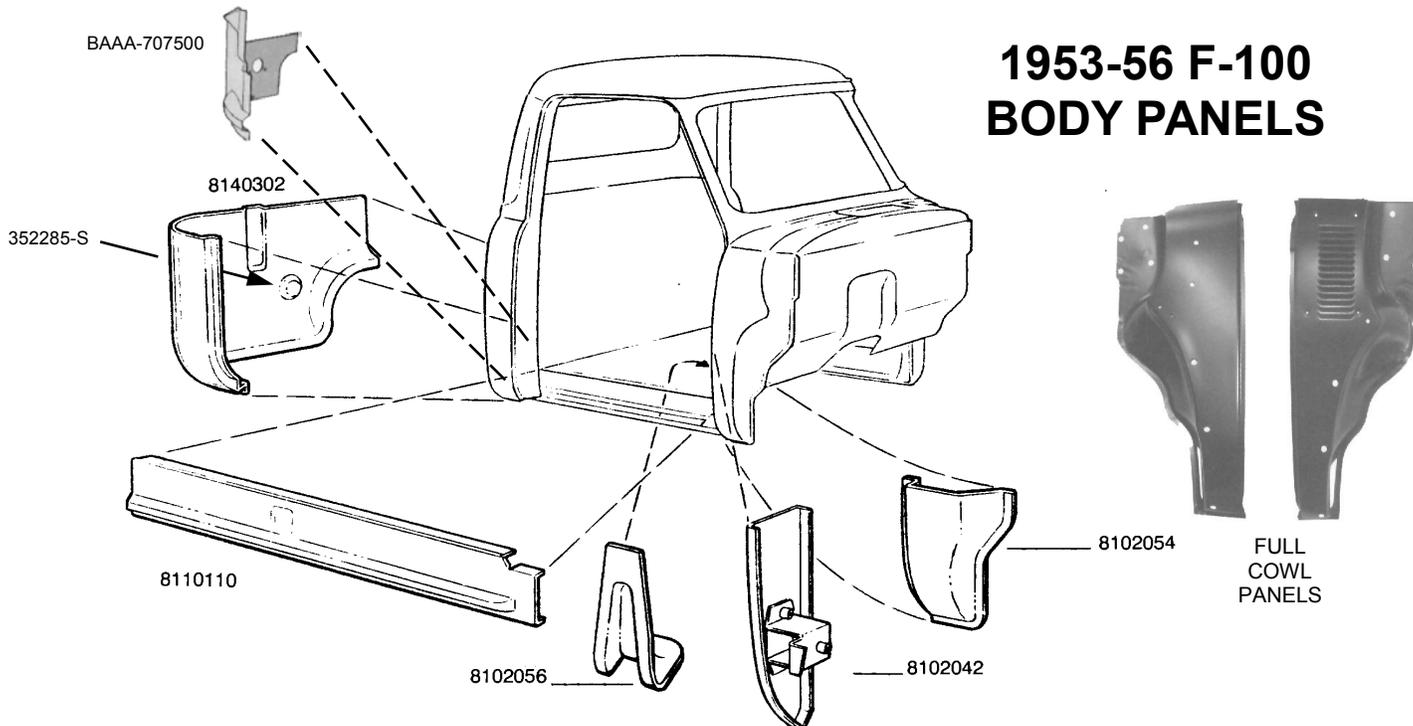

**1953-56 F-100
BODY PANELS**

REAR LOWER CAB CORNER

1953-56, Rear Lower Cab Corners

BAAA-8140302-R Right Side	each	45.00
BAAA-8140303-L Left Side	each	45.00
BAAA-8140302-PR	pair	90.00

INNER REAR CAB CORNER

1953-56, Right Side

BAAA-707500	each	60.00
-------------------	------	-------

1953-56, Left Side

BAAA-707501	each	60.00
-------------------	------	-------

ROCKER PANEL

1953-56, Die stamped with correct contour, Left Side

BAAA-8110110-L	each	35.00
----------------------	------	-------

1953-56, As Above, Right Side

BAAA-8110110-R	each	35.00
----------------------	------	-------

RUBBER PLUG FOR REAR OF CAB

1953-56, 1-1/2" hole plug		
352285-S	each	3.00

FRONT BODY MOUNT

1953-56, Front Body Mount, Right Side		
BAAA-8102056-R	each	30.00
1953-56, Front Body Mount, Left Side		
BAAA-8102057-L	each	30.00

FRONT CAB CORNER

1953-56, Front Cab Corners, 21" tall

BAAA-8102054-R Right Side	each	50.00
BAAA-8102055-L Left Side	each	50.00
BAAA-8102054-PR	pair	100.00

FULL COWL PANELS

1953-56, Front Outer Side Cowl Panel

BAAA-8102054-FR Full, Right Side ...	each	60.00
BAAA-8102055-FL Full, Left Side	each	60.00

COWL REINFORCEMENT

1953-56, Spot welds inside of Cowl to reinforce Fender

BAAA-8102054-IR Right Side	each	25.00
BAAA-8102055-IL Left Side	each	25.00

LOWER DOOR PILLAR

1953-56, Front, with lower hinge bucket installed, R.H.		
BAAA-8102042	each	50.00
1953-56, As Above, Left Hand		
BAAA-8102043	each	50.00
1953-56, Rear, Right Hand		
BAAA-8102042-RR	each	35.00
1953-56, As Above, Left Hand		
BAAA-8102043-RR	each	35.00

1948-56 BODY PANELS

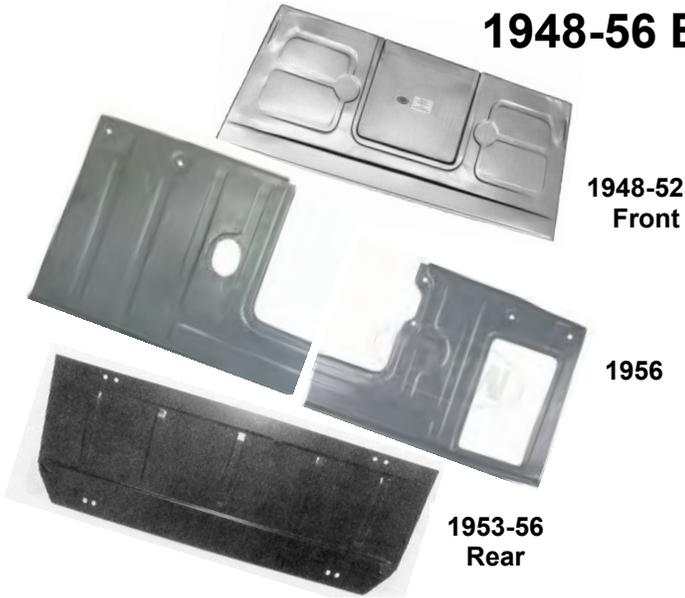

FRONT FLOOR PAN SECTION

1948-52, Front Cab Floor Pan, one piece, front section 7C-8111106-S	each	185.00
1948-52, 1/2 Floor Pan, Left Side 7C--8111106-L	each	80.00
1948-52, 1/2 Floor Pan, Right Side 7C-8111106-R	per side	80.00
1953-55, Front Cab Floor Pan, Right or Left Side BAAA-8111106-S	per side	80.00
1956, Front Cab Floor Pan, Right or Left Side B6C-8111106-S	per side	80.00

REAR FLOOR PAN SECTION

1953-56, Under Seat, Rear Cab Floor Pan, one piece BAAA-8111107	each	195.00
--	------	--------



FLOOR PAN ASSEMBLY

1948-52, F1-F7, Complete Floor Pan Assembly, with rockers, Not for cab over 7C-8111105	each	600.00
---	------	--------

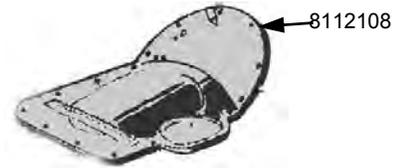

TRANSMISSION COVER

1948-52, Fiberglass 7C-8112108-F	each	60.00
1948-52, Steel, USA Made 7C-8112108-ST	each	100.00
1953-56, Fiberglass BAAA-8112108-F	each	60.00
1953-56, Steel BAAA-8112108-ST	each	59.00

TRANSMISSION COVER TO FLOOR SEAL

1948-52, Cork and Rubber, 3 pieces 7C-8112125-S	set	20.00
--	-----	-------

TOP OF TRANSMISSION TO COVER SEAL

1948-52, For floor shift only 7C-8112130	each	10.00
---	------	-------

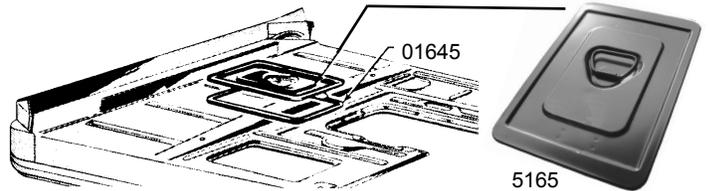

BATTERY HOLD DOWN COVER

1953-55, with handle BAAA-5165	each	49.00
1956, with handle B6C-5165	each	49.00

BATTERY HOLE COVER SEAL

1953-55 BAAA-8101645-B	each	12.00
1956 B6C-8101645-B	each	12.00



8120200

OUTER DOOR BOTTOM PATCH

1948-52, Left Side		
7C-8120200-L	each	60.00
1948-52, Right Side		
7C-8120200-R	each	60.00
1953-56, Right Side, correct contour		
BAAA-8120200-R	each	45.00
1953-56, Left Side, correct contour		
BAAA-8120201-L	each	45.00



INNER DOOR BOTTOMS

1948-52 Right Side		
7C-812024-R	each	69.00
1948-52 Left Side		
7C-812024-L	each	69.00
1953-56, Inner Door Lower Patch Panel, 7 1/2" high, Right Side		
BAAA-8120124-R	each	49.00
1953-56, As Above, Left Side		
BAAA-8120124-L	each	49.00



1956 ROOF SKIN

1956, Stamped Steel as original		
B6C-8150202-A	each	350.00

1956 ROOF DRIP RAIL SET

1956, 3 piece set, Stamped Steel as original		
B6C-8151724-SET	set	140.00

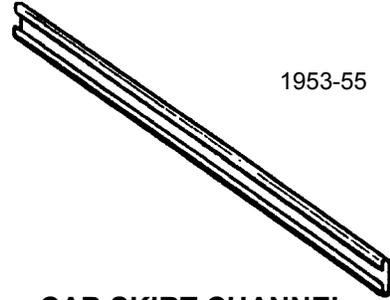

1953-55

CAB SKIRT CHANNEL

1953-55, Cab Skirt Channel, does not include rubber		
BAAA-8110112-PR	pair	17.50

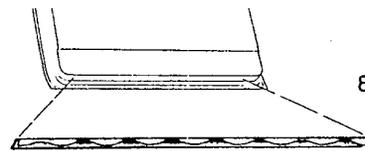

8120712

DOOR BOTTOM SEAL RETAINER

1953-56, Inner Door Bottom Seal Retainer		
BAAA-8120712	pair	8.00



DOOR

1953-55, Door shell, steel, right side		
BAAA-8120122-A	each	475.00
1953-55, Door shell, steel, left side		
BAAA-8120123-A	each	475.00
1956, Door shell, steel, right side		
B6C-8120122-A	each	coming
1956, Door shell, steel, left side		
B6C-8120123-A	each	coming

21C-8301110-P

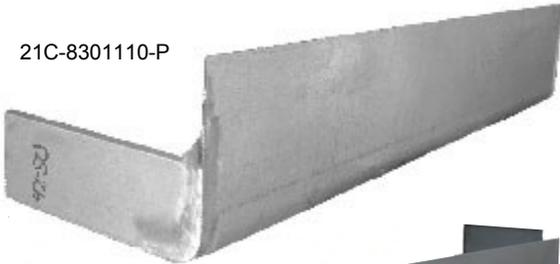

BAAA-8301110-P

ROLL PAN

1948-Early 50, Roll Pan, Plain		
21C-8301110-P	each	130.00
Late 1950-56, Roll Pan, Plain		
BAAA-8301110-P	each	130.00

21C-8301110-LR

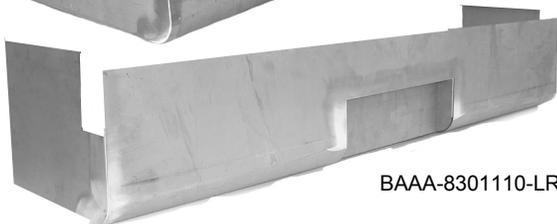
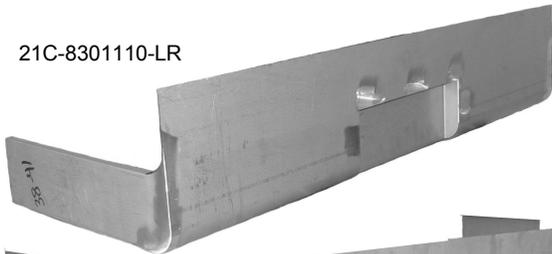

BAAA-8301110-LR

ROLL PAN WITH LICENSE PLATE RECESS

1948-Early 50, Roll Pan with license plate recess		
21C-8301110-LR	each	160.00
Late 1950-56, Roll Pan with license plate recess		
BAAA-8301110-LR	each	160.00

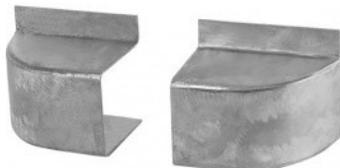

LOWER STAKE POCKET EXTENSIONS

1950-56, Lower Stake Pocket Extensions. A must when running a rear roll pan on your bed		
BAAA-8310534	pair	45.00

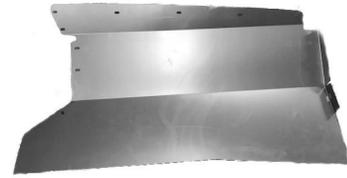

SMOOTH STEEL INNER FENDER

1953-56, F-100-350, 18 gauge steel		
BAAAD-16054/5-SM	pair	219.00



BIG REAR WINDOW CONVERSION PANEL

1953-56		
B6C-704280	each	599.00

BIG REAR WINDOW GLASS

1956		
B6C-704281	each	299.00



B6C-8140300-A

REAR CAB SECTION

1953-56, F100-F800, Small rear window		
B6C-8140300-A	each	495.00
1956, F100-F800, Big rear window		
B6C-8140300-B	each	495.00



GM ALTERNATOR MOUNTING BRACKETS

1948-53, For mounting GM Alternators on '48-53 Ford Engines, plain steel.

916-67910 each 50.00

1948-53, As Above, Chrome

916-67910-CH each 85.00

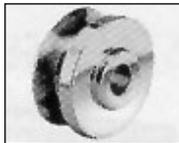

GM ALTERNATOR PULLEY

1948-53, Uses original 5/8" belt to turn water pumps and GM Alternator, plain steel.

910-16250 each 18.00

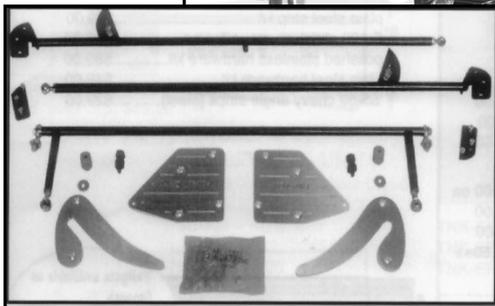

TILT HOOD KIT

1953-56, F-100, Featuring Billet roller mounts and tracks. We use rod ends and bearings for the pivots and adjustments. The hood braces are adjustable and the prop rod is carried on the hood brace and is attached to the core support, easy to install.

FTHK kit 390.00



EARLY FORD "LOGO" T-SHIRTS

Available in Black only, sizes: S, M, L, XL, 2XL, 3XL

BL-3002 each 10.00



Tan
W/Black
Bill



Blue
Denim

EARLY FORD EMBROIDERED "LOGO" HATS

Blue Denim with embroidered color Logo

EF-3000-T each 9.00

Tan Denim with embroidered color Logo

EF-3002-T each 9.00

Tan with Black Bill and embroidered color Logo

EF-3001-D each 9.00



STAINLESS STEEL BOLT KITS

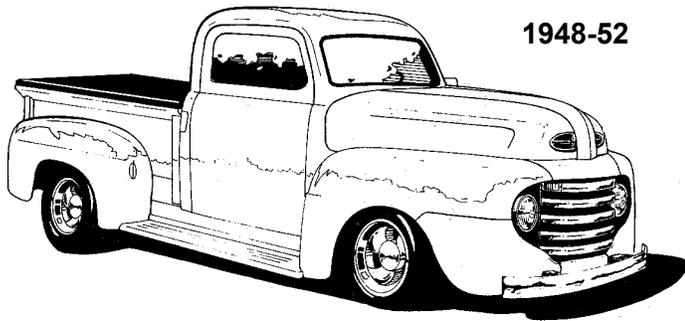

1948-52

1948-52 STAINLESS BOLT KITS

BEDLESS BODY KITS--762 PIECES

1948-50, Hex and Hex Nuts		
6-0363	kit	238.00
1948-50, Button/Socket Head		
6-0362	kit	242.00
1951-52, Hex and Hex Nuts		
6-0365	kit	228.00
1951-52, Button/Socket Head		
6-0364	kit	234.00

STEPSIDE BODY KITS--1152 PIECES

1948-50, Button/Socket Head		
6-0301	kit	390.00
1948-50, Hex and Hex Nuts		
6-0302	kit	384.00
1951-52, Button/Socket Head		
6-0359	kit	379.00
1951-52, Hex and Hex Nuts		
6-0357	kit	369.00

BODY MOUNT KITS

1948-52, Hex Head, includes bolts for front cab mounts		
6-0329	kit	30.00

REAR BUMPER KITS

1948-52, Hex/Carriage, unpolished 1/2" Carriage Bolts		
6-0345	kit	33.00

DOOR HINGES, LATCH & CATCH KITS

1948-52, Does exposed door hinge bolts, Phillips Head		
6-0333	kit	14.00

DOOR HARDWARE KIT

1948-52, Inside of door, includes latch, regulator, inspection cover. Phillips Head		
6-0361	kit	13.00

COMPLETE FRONT SHEET METAL KITS

1948-52, Hex and Carriage, Front and Inner Fenders, Header Panel and Splash Pan		
6-0304	kit	53.00

GRILLE TOP & SUPPORT & HORN BRACKET

1948-50, Hex Head		
6-0326	kit	12.00

INTERIOR KIT

1948-52, Original Style		
6-0335	kit	20.00

HOOD KITS

1948-50, Hex Head, Latch, Catch, Braces, Hinges		
6-0321	kit	14.00
1951-52, Hex Head, Latch, Catch, Braces, Hinges		
6-0324	kit	13.00

RADIATOR SUPPORT & BRACES KITS

1948-52, Hex Head		
6-0318	kit	41.00

RUNNING BOARD KIT

1948-52, Carriage Head, does both boards		
6-0331	kit	19.50

TAILGATE, TAIL LIGHTS & LICENSE PLATE

1948-56, Button and Acorns		
6-0264	kit	22.00
1948-56, Button and Hex Nuts		
6-0265	kit	16.00
1948-56, Hex and Acorns		
6-0222	kit	23.00
1948-56, Hex and Hex Nuts		
6-0220	kit	15.00

REAR FENDER TO BED SIDE BOLTS

1948-56, F-1, Takes 24, as original, 5/16" x 24, 5/8"		
7C-355471-S	set of 24	20.00
1948-56, Bolt, nut and washer kit, Stainless, unpolished		
7C-355471-SS	set of 24	30.00
1948-56, As Above, Polished Stainless		
7C-355471-SSP	set of 24	40.00

STAINLESS BED TO FRAME BOLT KIT

1948-52, Polished Stainless Steel		
T-1104	kit	52.00

1953-56 STAINLESS STEEL BOLT KITS



1953-56

BEDLESS BODY KITS--659 pieces

1953-56, Hex Heads 6-0272	kit	224.00
1953-56, Correct Heads 6-0293	kit	244.00

STEPSIDE BODY KITS--1072 pieces

1953-56, Hex Heads 6-0255	kit	349.00
1953-56, Correct Heads 6-0294	kit	387.00

REAR BUMPER KITS

1953-56, Hex/Carriage, unpolished 1/2" Carriage Bolts 6-0232	kit	23.00
---	-----	-------

COWL VENT KIT

1953-56, Original Style, passenger side 6-0262	kit	4.00
---	-----	------

DOOR HINGE KITS

1953-56, Button Head, does both doors 6-0875	kit	12.00
1953-56, Hex Head, does both doors 6-0217	kit	9.00

DOOR JAMB KITS

1953-56, Button/Flat Socket, does both doors 6-0218	kit	17.00
1953-56, Phillips Head, does both doors 6-0254	kit	15.00

FIREWALL KIT

1953-56, Self Tapping & Nuts, has 32 pieces 6-0256	kit	10.00
---	-----	-------

FRONT BED PANEL KITS

1953-56, Button Head, bolts at top 6-0266	kit	4.00
1953-56, Hex Head, bolts at top 6-0267	kit	3.00

CAB MOUNT BOLT KIT

1953-56, Not included in complete body kits. Hex Head 6-0275	kit	39.00
---	-----	-------

F-100 STAINLESS FRONT END BOLT KIT

1953-56, Complete stainless Bolt Kit for front fenders, inner fender panels, grille valance pan, air deflectors, hood latch pan and rods. Includes all necessary bolts, nuts, flat and lock washers.

BAAA-16000-MBSS	kit	55.00
-----------------------	-----	-------

FRONT FENDER BRACE KITS

1953-56, Button Head 6-0259	kit	9.00
1953-56, Hex Head 6-0205	kit	8.00

FRONT & INNER FENDER BOLT KIT

1953-56, Button Head, Front & Inner Fenders, 180 pcs. 6-0251	kit	50.00
1953-56, Hex Head, Front & Inner Fenders, 180 pcs. 6-0252	kit	39.00

HOOD BRACE KITS

1953-56, Button Head 6-0257	kit	6.00
1953-56, Hex Head 6-0209	kit	6.00

HOOD HINGES KIT

1953-56, Acorn Nuts, does both, use with stock grooved washers 6-0206	kit	5.00
--	-----	------

HOOD LATCH KITS

1953-56, Button Head, use with stock "Cookie Cutter" washers 6-0213	kit	4.00
1953-56, Hex Head, use with stock "Cookie Cutter" washers 6-0214	kit	4.00

INTERIOR KIT

1953-56, Original Style 6-0263	kit	23.00
---	-----	-------

REAR FENDER BOLT KIT

1948-56, 24 pieces, polished stainless 7C-355471-SSP	kit	40.00
---	-----	-------

RUNNING BOARD BOLT KIT

1953-56, Does both sides, includes bracket bolts, Hex and Hex Nuts 6-0237	kit	35.00
--	-----	-------

STAINLESS BED TO FRAME BOLT KIT

1953-56, Polished Stainless Steel T-1102	kit	50.00
---	-----	-------

1-800-543-5035  Springfield, OH  MidwestEarlyFord.com

MOTOR MOUNT KITS

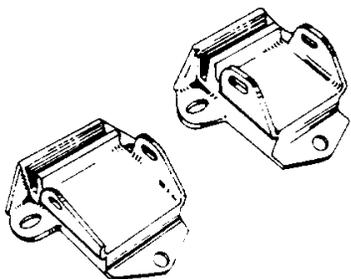

CHEVROLET FRAME MOUNT PADS

These special Frame Mount Pads are made to complete the installation of #4810.

2142 pair 35.00

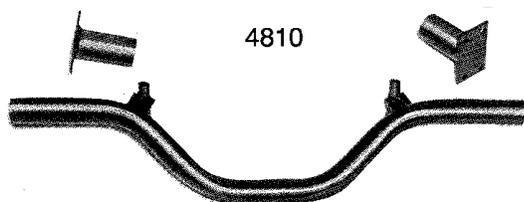

**CHEVROLET V-8
UNIVERSAL FRAME MOUNT**

One piece Mount makes possible the installation of the Chevrolet engine into earlier frames. Adjustment of frame widths of 24" to 37".

4810 kit 75.00



FORD UNIVERSAL FRAME MOUNT

One piece saddle style mount makes possible the installation of the popular small block Ford 221-351 Windsor. Also fits 1972-earlier Cleveland engines into many earlier frames. Frame widths of 24" to 37". Requires some welding.

4819 kit 72.00

NOTE: Requires our pad set #2310 to complete installation.



**FORD 351-400 CLEVELAND & M
UNIVERSAL FRAME MOUNT**

Saddle style mount enables installation of the 1973-up Ford Cleveland 351-400 engines into 1948-66 Ford Pickups and earlier Ford and Chevrolet frames. Adjusts to frame widths of 24" to 37". Some welding required.

4977 kit 72.00

NOTE: Requires use of our pad set #4981 to complete installation

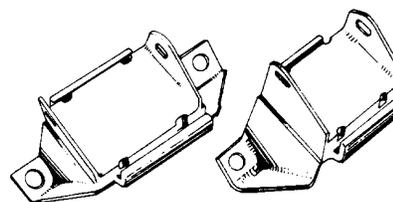

**FORD 221-351 WINDSOR FRAME
MOUNT PADS**

These special pads make available the installation of our #4819 mount.

2310 pair 48.00

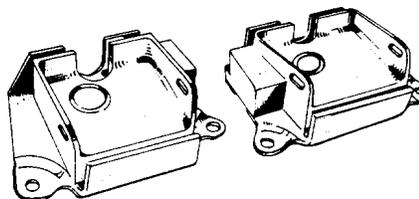

**FORD 351-400 CLEVELAND FRAME
MOUNT PADS**

These special pads made available to complete the installation of our #4977 mount.

4981 kit 58.00

MOTOR MOUNT KITS



429-460 FORD UNIVERSAL FRAME MOUNT

Mounts 429-460 Ford engines into 1948-66 Ford 2WD pickups as well as earlier Ford and Chevy frames. Adjustable to frame widths of 28" to 38" for vehicles with open frame rails. Requires the use of pads #42960 to complete installation.

9313 kit 125.00



429-460 FORD MOTOR MOUNT PADS

Fits Motor Mounts 9313 above.

42960 pair 80.00

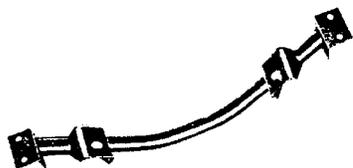

**FORD FE BLOCK
332-352-390-406-427-428
INTO 1953-64 FORD PICKUP**

One piece mount makes the popular big-block Ford engine to 1948-64 Ford Pickup swap. Includes bolt to frame crossbar, designed for frame widths of 28-3/4", hardware and complete installation information. NOTE: If pan hits mount, use passenger car 4-qt. oil pan.

4037 kit 95.00

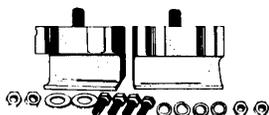

FORD MOTOR MOUNT PADS

Motor Mount Pads are made available to fit between the Big Block Ford engine when installing the #4037 Motor Mount. Sold in pairs with studs, nuts & washers.

4715 pair 50.00



CHEVROLET RUBBER/STEEL STYLE TRANSMISSION MOUNT PAD

Rubber/steel construction. Fits most standard and automatic Chevrolet transmissions except Turbo 400.

9402 kit 18.00



TRANSMISSION TUBULAR CROSSMEMBER MOUNT

This Transmission Mount adjusts to fit frame rails of 26" to 36" in width and will work with most standard and automatic transmissions. Heavy duty steel..

9424 kit 72.00



**FORD TRUCK
UNIVERSAL TRANSMISSION MOUNT**

Braces or mounts in 1948-66 Ford pickup trucks. Mounts in channel of frame or under frame to support the automatic transmission.

4136 each 59.00



TRANSMISSION MOUNTING PAD

Special mounting pad made available to go between the Ford C-4 or C-6 automatic transmission when using our #4136 transmission mount.

4716 kit 20.00

NOTE: This pad may need slight reworking on some C-6 adaptations.





WELD-IN INDEPENDENT SUSPENSION KIT

Complete kit includes Rotors, Calipers, Tubular A Arms, Shocks, Coil Springs, Spindles, hardware with manual rack. Available with power rack —add 100.00

GM bolt pattern

JW-1040 kit 1599.00

As Above, Ford bolt pattern.

JW-1042 kit 1699.00

Free Shipping does not apply to this item

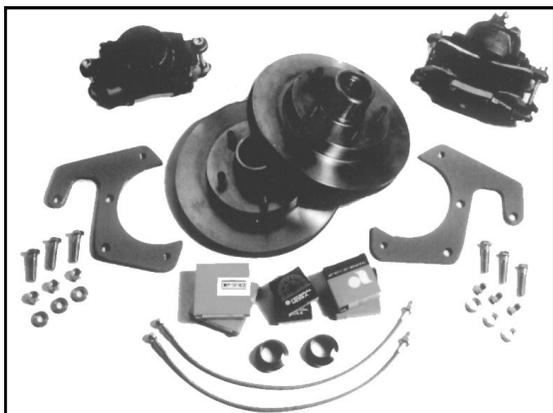

DISC BRAKE KIT

1948-56, F-100, Ford 4-1/2" Disc. Complete kit includes Rotors, Calipers, Hoses, Caliper Mounts, Bearings, Seals and Hardware

ED-456-C kit 435.00

As Above, Ford 5-1/2" Disc.

ED-536-C kit 435.00



MASTER CYLINDER ADAPTER

1948-52, This kit converts the original single reservoir Master Cylinder to a dual reservoir system , includes Adapter Plate and Master Cylinder

7C-2140-KIT kit 175.00

1948-52, As Above, Adapter Plate only

2140-ADT each 80.00

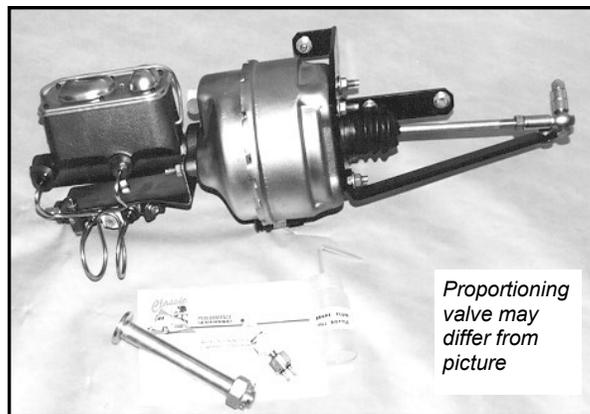

Proportioning valve may differ from picture

BRAKE BOOSTER KIT

Specify Disc front or rear. Kit includes: Booster, Booster Bracket, Master Cylinder, Proportion Valve, Stainless lines from Master to Prop Valve and all hardware. With instructions.

1948-52, Ford Trucks

D-4852BB2 kit 450.00

1953-56, Ford Trucks, Disc Front, Drum Rear

D-5356BB2 kit 450.00

Will not work with original Clutch Linkage



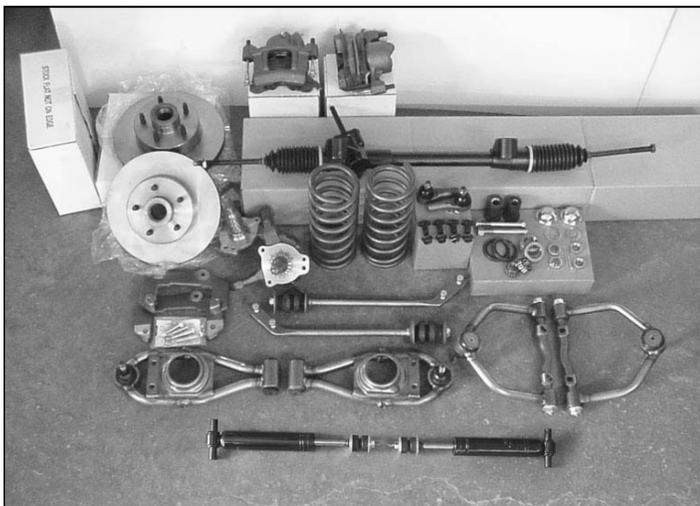

BOLT-IN INDEPENDENT SUSPENSION KIT

Complete kit includes Rotors, Calipers, Tubular A Arms, Shocks, Coil Springs, Spindles, hardware, with manual steering. Less Motor Mounts. GM bolt pattern, 4-3/4" x 5

- CE-4852-C kit 2395.00
- As Above, Ford bolt pattern, 4-1/2 x 5
- CE-4852-F kit 2395.00

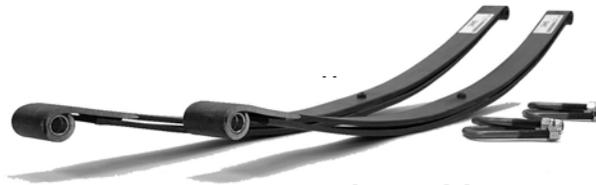

DUAL FLEX SPRINGS
Lowers approx. 3" Front

- 1948-52, F-1, Front, includes "U" bolts
7C-152-FDF pair 375.00
- 1953-56, F-1, Front, includes "U" bolts
BAAA-154-FDF pair 375.00

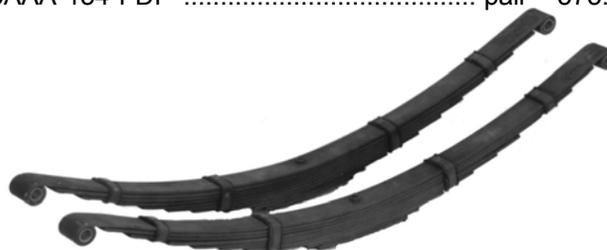

SUPER SLIDE SPRINGS
Lowers approx. 3" Rear, approx. 2" Front

- 1948-52, F-1, Front
7C-152-FSS pair 400.00
- 1953-56, F-1, Front
BAAA-154-FSS pair 400.00
- 1948-52, F-1, Rear
7C-152-RSS pair 375.00
- 1953-54, F-1, Rear
BAAA-154-RSS pair 375.00
- 1955-56, F-1, Rear
B5C-155-RSS pair 375.00

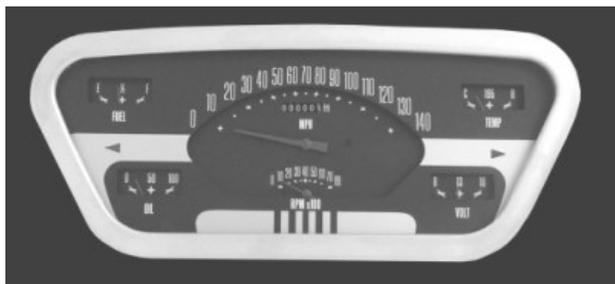

DASH INSERT WITH GAUGES

1953-55, F-100, Complete retro-fit unit with all 12 gauges, including speedometer, tachometer, water temp, oil pressure and volt gauges. LED lighting, turn indicators, with sending units, comes in Gray, White, Black and Tan, Use original fuel sending unit.

- FT53-11804 each 875.00

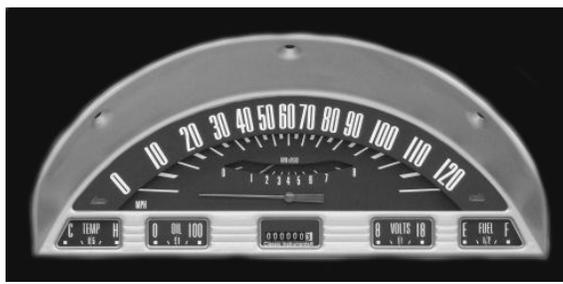

DASH INSERT WITH GAUGES

1956, F-100, Complete retro-fit unit with all 12 gauges, including speedometer, tachometer, water temp, oil pressure and volt gauges. LED lighting, turn indicators, with sending units, comes in Gray, White, Black and Tan, Use original fuel sending unit.

- FT56-11804 each 875.00



1948-50 ALUMINUM DASH INSERT
No Dash Modification Needed

1948-50, Brushed aluminum with polished edges, includes indicator lights. Gauges sold separately.
7C-11804 each 80.00



1951-52 DASH ADAPTER RINGS
No Dash Modification Needed

1951-52, Adapter Rings for 1951-52 Dash are designed to take the Classic Quad-Cluster Gauges which are sold separately. See next page
1C-11804 pair 75.00



1948-50 ALUMINUM DASH INSERT

1948-50, Quad 3-3/8", Gauges sold separately.
KUSC-120348 each 130.00



No Dash Modification Needed

1953-55 ALUMINUM DASH INSERT

1953-55, Allows you to run modern gauges sold separately, comes with indicator lights.
BAAA-11804 each 79.00



1948-50 ALUMINUM DASH INSERT

1948-50, 5 Gauges 3-3/8", or 3-1/8 Speedo opening, Gauges sold separately.
KUSC-120548 each 130.00



No Dash Modification Needed

1953-55 ALUMINUM DASH INSERT

1953-55, Allows you to run modern gauges sold separately, polished billet aluminum
KUSC-120553 each 130.00

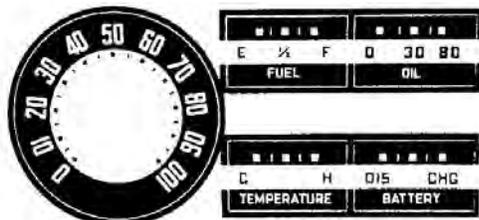

INSTRUMENT PANEL DECAL

1948-50, F-1--F-8, Speedometer & Gauges
7C-17255-DP set 40.00



1956 ALUMINUM DASH INSERT
No Dash Modification Needed

1956, Allows you to run modern gauges sold separately, comes with indicator lights.
B6C-11804 each 85.00



1951-52 Pickup Gauge Kit

From Midwest Early Ford in Springfield, Ohio



NEW VINTAGE GAUGE KIT

1951-52 Woodward Series, 12 volt, 4-3/8" hole openings, Beige w/ stainless rings, includes oil and temperature sending units.
 NV-1937-BGE 2 gauge kit **399.00**



NEW VINTAGE GAUGE KIT

1951-52 Woodward Series, 12 volt, 4-3/8" hole openings, Black with stainless rings, includes oil and temperature sending units.
 NV-1937-BLK 2 gauge kit **399.00**

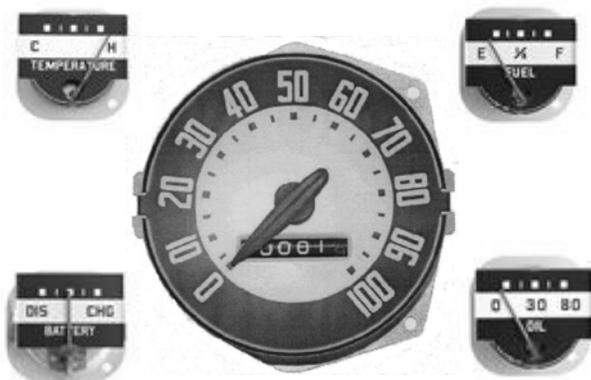

REPLACEMENT SPEEDOMETER

1948-50 With Backing Plate
 7RC-17255-A each 150.00
 7RC-9280 1948-50, Fuel Gauge each 85.00
 7RC-9273 1948-50, Oil Pressure Gauge each 85.00
 7RC-10883 1948-50, Temp. Gauge each 85.00
 8C-10850 1948-50, Ammeter Gauge each 85.00



REPLACEMENT SPEEDOMETER

1951-52 Speedometer Cluster
 1C-17255-A each 150.00
 1C-9280-A 1951-52, Fuel Gauge each 85.00
 1C-9273-A 1951-52 Oil Pressure Gauge each 85.00
 1C-10883-A 1951-52 Temp. Gauge each 85.00
 1C-10850-A 1951-52 Ammeter Gauge . each 85.00

NEW VINTAGE



NEW VINTAGE GAUGE KIT

1951-52 Woodward Series, 4-3/8" hole openings, Beige with stainless rings, includes oil and temperature sending units.

NV-1937-QT-BGE **2 gauge kit 549.00**

1951-52 As Above, Black with stainless rings

NV-1937-QT-BLK **2 gauge kit 549.00**

1951-52 As Above, White with stainless rings

NV-1937-QT-WTE **2 gauge kit 549.00**



NEW VINTAGE GAUGE KIT

1951-52 Woodward Series, 4-3/8" hole openings, Beige with stainless rings, includes oil and temperature sending units, with Tach.

NV-1937-ST-BGE **2 gauge kit 549.00**

1951-52 As Above, Black with stainless rings

NV-1937-ST-BLK **2 gauge kit 549.00**

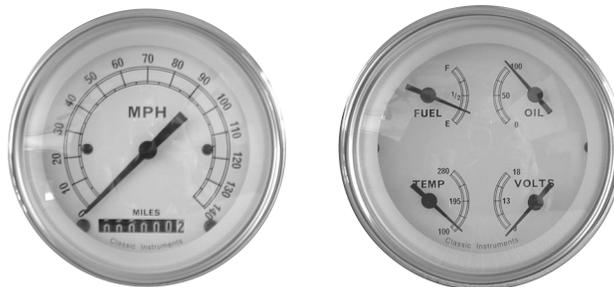

CLASSIC SERIES

Chrome Bezel, white face, black needle. The kit includes the Speedometer Gauge and matching **Quad Cluster**.

CW-5576-CLC kit 375.00

VINTAGE SERIES

Polished Brass Bezel, tan faced with red needle. The kit includes the Speedometer Gauge and matching **Quad Cluster**, 3-3/8" diameter

VT-5576-CLC kit 375.00

TRADITIONAL SERIES

Chrome Bezel, black face, white needle. The kit includes the Speedometer Gauge and matching **Quad Cluster**.

TR-5576-CLC kit 375.00

Classic Tach—state style when ordering 120.00

NEW ITEM

Available with Autometer or Classic Instruments

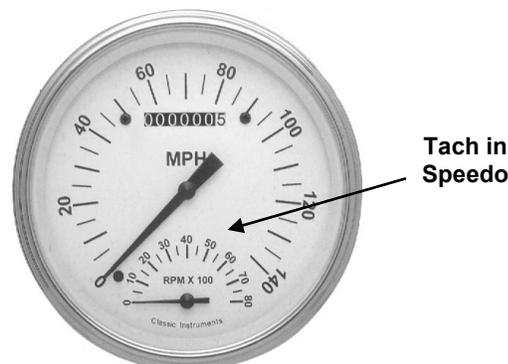

Many More Gauges Available
Call with you needs!
Autometer—VDO—Classic Instruments



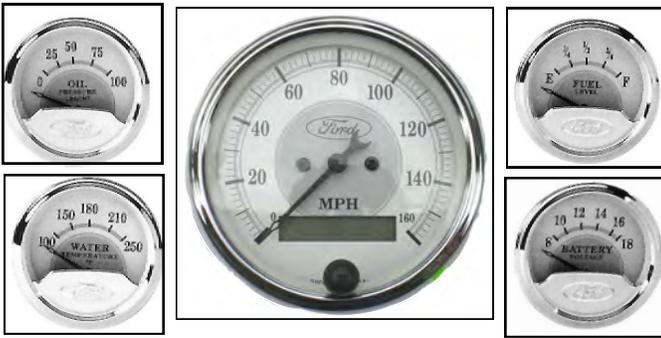

FORD MOTORSPORT GAUGE KIT

Complete 5 Gauge Kit comes with all necessary senders. Chrome/White Face. Less Tachometer. 3- 1/8 Diameter Speedo.

- M-19017-A961 kit **425.00**
- Ford Motorsport Tach 120.00

SPEEDO ADT RING

Must be used when installing Ford Motorsport Gauges in some Dash Inserts. Reduces Speedo hole from 3-3/8" to 3-1/8"

- 11804-ADT each **18.00**



GAS TANK ADAPTER RING

Must use when installing fuel sending unit into original gas tank. sending unit into original gas tank.

- O1A-9275-ADT kit **30.00**

11804-ADT

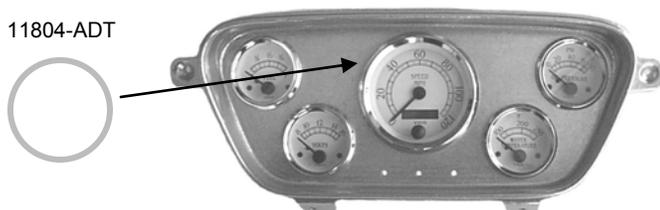

SPEEDO ADAPTER RING

Reduces 3-3/8" Speedo opening to accept 3-1/8" Speedo, plastic

- 11804-ADT Out of production



3-1/8" Mechanical Speedo



3-1/8" Electronic Speedo



5 GAUGE KITS WITH SENDERS

- White face with Chrome bezels. Mechanical Speedo
AM-1601 5 Gauge Kit **299.00**
- White face with Chrome bezels. Electronic Speedo
AM-1602 5 Gauge Kit **399.00**
- Tan face with Gold bezels. Mechanical Speedo
AM-1501 5 Gauge Kit **299.00**
- Tan face with Gold bezels. Electronic Speedo
AM-1502 5 Gauge Kit **399.00**
- Tan face with Chrome bezels. Mechanical Speedo
AM-1808 5 Gauge Kit **299.00**
- Tan face with Chrome bezels. Electronic Speedo
AM-1809 5 Gauge Kit **399.00**

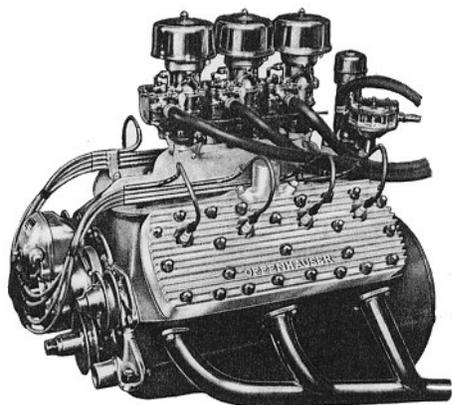

ALUMINUM HIGH COMPRESSION HEADS

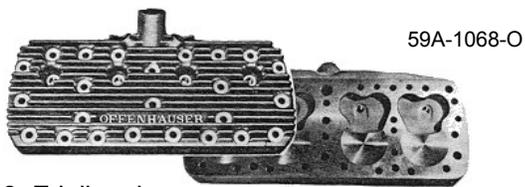

59A-1068-O

- 1939-48, Edelbrock
59A-1068-E pair 695.00
- 1939-48, Offenhauser
59A-1068-O pair 699.00

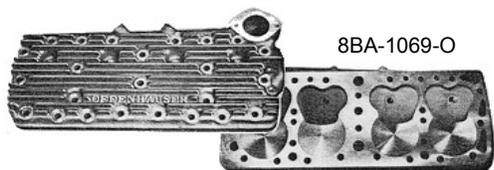

8BA-1069-O

- 1949-53, Edelbrock
8BA-1069-E pair 695.00
- 1949-53, Offenhauser
8BA-1069-O pair 699.00

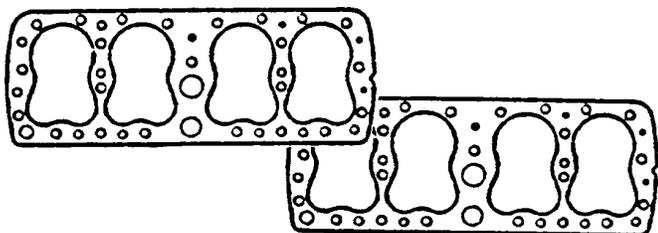

BIG BORE HEAD GASKETS

- 1939-48, Copper
91A-6051-BB each 50.00
- 1949-53, Copper
8BA-6051-BB each 50.00

OFFENHAUSER ALUMINUM INTAKE MANIFOLDS



- 1932-48, Dual Carburetor
59A-1090 each 375.00
- 1949-53, Dual Carburetor
8BA-1075 each 375.00



- 1949-53, Triple Carburetor
8BA-1077 each 425.00



- 1932-48, 4 Barrel Carburetor
59A-1079 each 375.00
- 1949-53, 4 Barrel Carburetor
8BA-1078 each 375.00



6521 →

INTAKE MANIFOLD GASKET

- 1948-53, V-8
8BA-6521 each 12.00

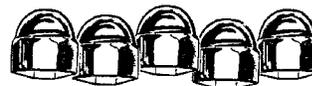

CYLINDER HEAD NUT COVERS

- 1948-53, All, Chrome Plated, set of 50
CNC-6062-AS set 30.00

INTAKE MANIFOLD BOLT HEAD COVERS

- 1932-48, All, Chrome Plated, set of 20
CNC-6063-S set 12.00

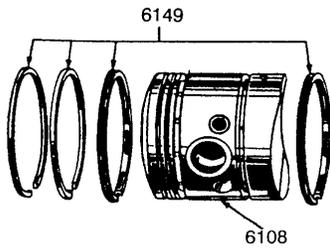

BIG BORE PISTONS

- 3-5/16 Bore x 4" Stroke, 4-Ring, Set of 8
CM-6108-B set 260.00
- 3-3/8 Bore x 4" Stroke, 4-Ring, Set of 8
CM-6108-C set 260.00
- 3-3/8 Bore x 4-1/8" Stroke, 4-Ring, Set of 8
CM-6108-D set 260.00

BIG BORE PISTON RINGS

- 3-5/16 Size
CM-6149-B set 70.00
- 3-3/8 Size
CM-6149-C set 70.00

FLATHEAD EXHAUST HEADERS



- 1932-53, Fenton, Cast Iron
59A-9430-CH pair Discontinued



- 1948-52 Pickup, V-8
7C-9431-SH pair 260.00
- 1953 Pickup, V-8
BA-9431-SH pair 295.00

EXHAUST MANIFOLD GASKETS

- 1948-53, 239 V-8
18-9433 set of 8 7.50
- 1955-56, Exhaust Manifold Gasket Set
B7AZ-9433-A set 20.00



HOT ROD STYLE AIR CLEANER

- All years, 4" covered chrome top, 2-5/8" carburetor opening
- B-9600-HR Replacement..... each 15.00
 - F-9600 Filter for Above each 4.00



WATER OUTLET HOUSING

- 1949-53, V-8, Polished Aluminum
1BA-8592 each 15.00
- 8BA-8255, Gasket for above each 1.00

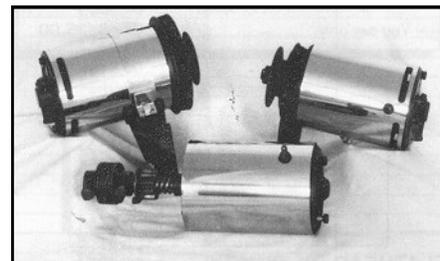

STAINLESS GENERATOR COVERS

- 1948-53, Generator Cover
8BA-10000-C each 35.00
- 1948-56, Starter Cover
59A-11000-C each 30.00



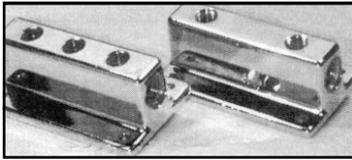

FUEL BLOCKS

Chrome plated die cast Fuel Blocks 3/8" NPT Inlet. Outlets are 1/4" NPT.

MG-9283 Dual Outlet	each	18.00
MG-9284 Triple Outlet.....	each	18.00



FUEL BLOCK FITTINGS (Brass)

HR-3129-5 3/8" NPT with 5/16" hose ..	each	4.00
HR-3129-3 3/8" NPT with 3/8" hose	each	4.00
HR-3130-5 1/4" NPT with 5/16" hose ...	each	4.00
HR-3130-3 1/4" NPT with 3/8" hose	each	4.00

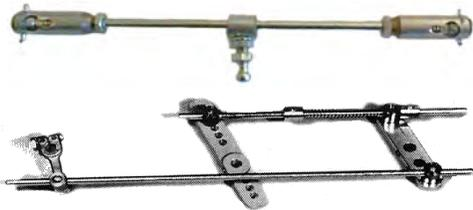

THROTTLE LINKAGE

1932-53, Dual Carburetor, Adjustable, Non-Progressive 59A-2864	kit	20.00
1932-53, Triple Carburetor, Adjustable, Progressive 59A-6271	kit	85.00



Measures
2" x 2-1/2"

AMBER PARK/TURN LIGHTS

Dual Filament, 12 volt, Park/Turn Light, approximately 2"x2-1/2" in size		
HR-13302-TS	each	12.00



NOSTALGIA FUEL LINE

Clear Red Fuel Resistant Superthane Tubing

HR-9369-A 5/16" I.D.	6 feet	15.00
HR-9369-B 3/8" I.D.	6 feet	15.00



FUEL PRESSURE REGULATOR

Adjustable from 1 to 6 lbs. Includes fittings, hose and clamps. Fits 5/8" and 3/8" I.D. fuel line. Not for fuel injected systems.

9710	each	30.00
------------	------	-------



**Famous
Deep Mellow
Tone!**



SMITHY MUFFLERS

A true 50's sound that is resonated through Smithy's legendary 22" mufflers. 3-1/2" diameter, 2" inlet/outlet		
SM-5120	pair	80.00



Midwest Early Ford is an Authorized Dealer for Walker Radiators. Call for a quote on the Walker Radiator to fit your application.



ALUMINUM RADIATOR

1948-52, with Ford engine		
7RC-8005-F	each	249.00
1948-52, with Chevrolet engine		
7RC-8005-C	each	249.00
1953-56, with Ford engine		
BAAA-8005-F	each	299.00
1953-56, with Chevrolet engine		
BAAA-8005-C	each	299.00

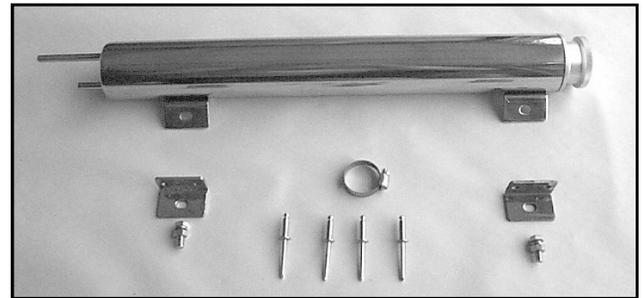

RADIATOR OVERFLOW TANK

Highly Polished Stainless Steel Tank with all mounting brackets, hardware and instructions.

1948-56, 13" long		
B-800-R13	each	49.00
1948-56, 15" long		
B-800-R15	each	49.00
1948-56, 17" long		
B-800-R17	each	49.00
1948-56, 19" long		
B-800-R19	each	49.00

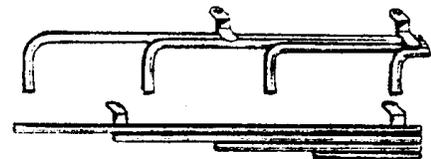

STAINLESS STEEL IGNITION LOOMS

1949-53		
8BA-12280-AS	pair	85.00

FREE SHIPPING

Pre-paid orders over \$1,000 are shipped free by UPS ground within the continental US. Free shipping does not apply to back orders, truck freight, UPS oversize (exceeding 48") or overweight (exceeding 70 lbs.).

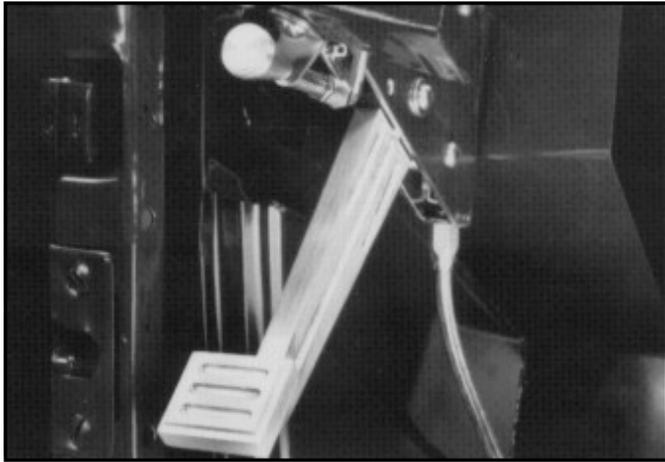

FOOT OPERATED EMERGENCY BRAKE

Features: Dash to firewall bracketry, various location mounting capabilities, heat treated gears, hidden mechanisms and gears, rubber stop for quiet pedal return, application for finished and unfinished cars, complete instructions and hardware, brake arm and foot pad also available in chrome plated aluminum, connector cables sold separately.

Billet finish			
EFB-9000	each		215.00
Chrome plated			
EFB-9001	each		215.00



EMERGENCY BRAKE CABLE

Brake Cable Kits come equipped with quality one-piece aluminum adjusters. Teflon lined housing and stainless inner cable to resist moisture. Design allows rear end backing plate fittings to be removed without removing Brake Cable. Also features adjustable cable lock and clevis.

Braided Stainless Teflon-lined housing, trans. mount			
EC-80-THT	each		206.00
Braided Stainless Teflon-lined housing, floor mount			
EC-80-FHT	each		206.00

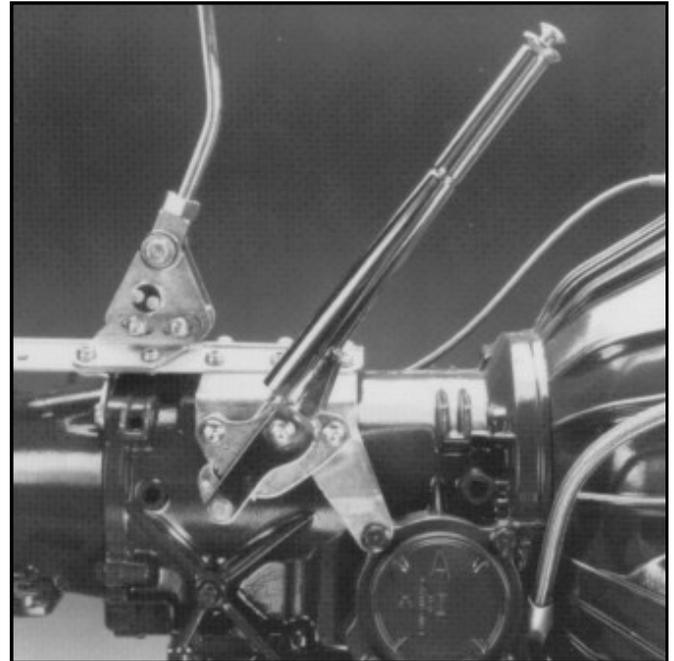

EMERGENCY HAND BRAKE

Gear plate and lock are heat treated for strength and safety. Available in 16" and 11" lengths.

11" lengths			
EHB-7011	each		140.00
16" lengths			
EHB-7016	each		140.00

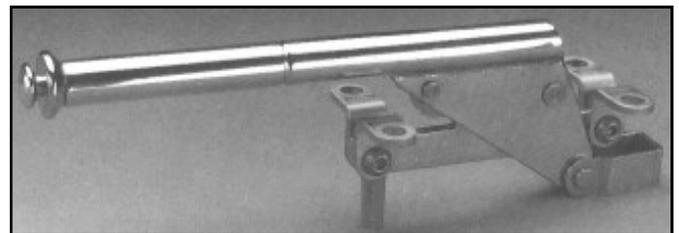

FLOOR MOUNT EMERGENCY HAND BRAKE

EHB-7000-F	each		123.00
------------------	------	--	--------

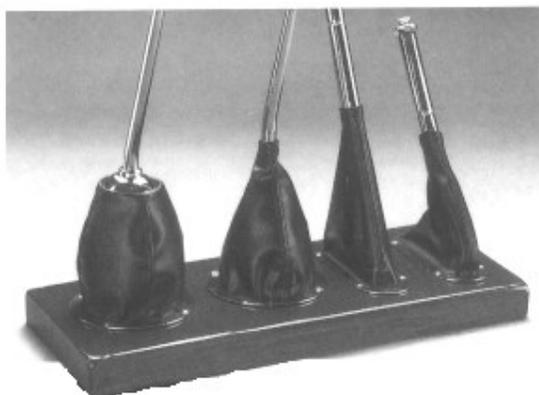

SHIFT/ BRAKE LEVER BOOT

Classic Boot		
70-CLB	each	36.00
Hot Rod Boot		
70-HRB	each	30.00
Floor Mount Brake Boot		
70-EHBF	each	30.00
Transmission Mount Brake Boot		
70-EHBT	each	30.00

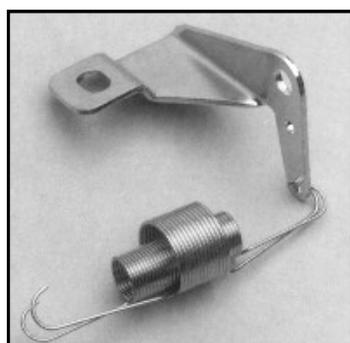

STAINLESS STEEL THROTTLE CABLE BRACKET AND SPRING

Bracket fits to the rear of Holly, Carter, AFB and Quadra-jet Carburetors
 SRK-4000 each 29.00

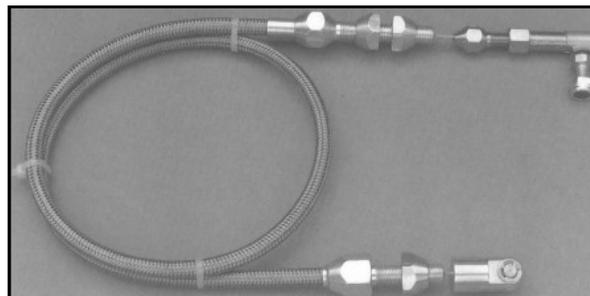

UNIVERSAL THROTTLE CABLE

Teflon lined braided cables designed with a specially extruded liner for extended life of the cable. Now equipped with new improved aluminum fittings and aluminum ferule to eliminate fraying. Outer housing is 24" with a stainless inner cable. Clevis is designed without cotter pins or set screws. Adapts to factory and aftermarket pedals. U-Cut to fit. Custom lengths available upon request.

24" Braided Stainless Housing		
TC-1000-HT	each	49.00

**Give your man what he really wants,
 a Gift Certificate from Early Ford**



Available in any amount

Call 1-800-543-5035



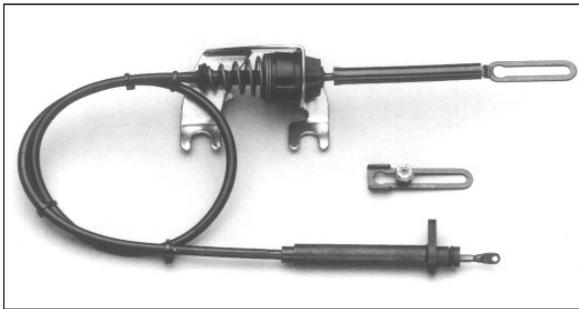

TH-350 KICKDOWN BRACKET AND CABLE

Stainless Bracket mounts on the back 2 manifold bolts. Designed for 4 barrel carburetors.

Bracket and Cable for small block Chevy KD-2350-U	each	43.00
Bracket Only KDB-4350	each	25.00

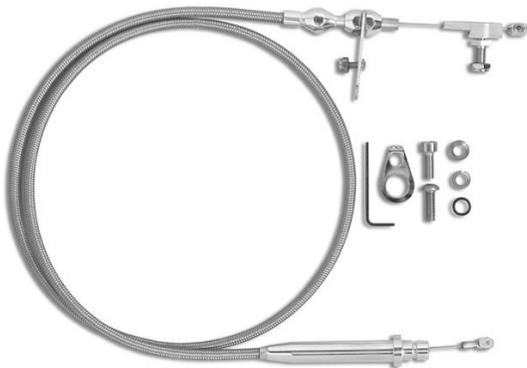

KICKDOWN KIT

Adaptable for all types of manifolds including tunnel-ram and blower manifolds. Our braided stainless cable is available for Chevy or Ford.

GM, TH-350 KD-2350-HT	each	82.00
GM, 700-R4 KD-2700-HT	each	82.00
FORD, C-4 KD-20C4-HT	each	82.00
FORD, C-6 KD-20C6-HT	each	82.00
FORD, AOD KD-2AOD-HT	each	82.00

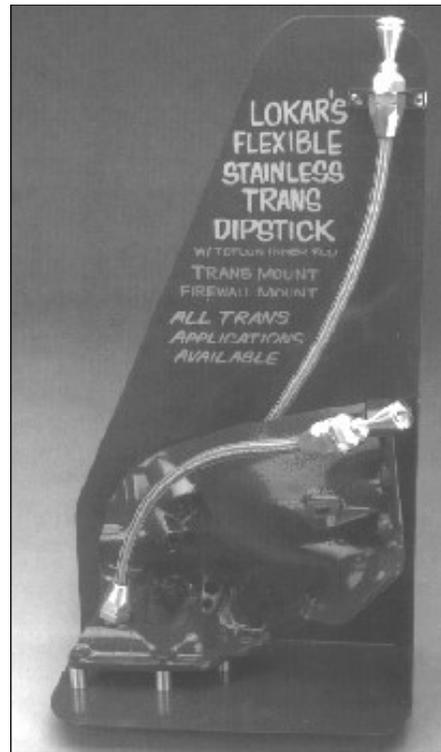

STAINLESS TRANSMISSION DIPSTICK

Choose from either our Transmount or 24" Firewall Mount Flexible Dipstick. Available for Chevy TH-350, TH-400, 700 R-4, Powerglide, Ford C-4, C-6. Funnel adapter included in kit.

Transmission Mount TD-3350-TM	each	78.00
24" Firewall Mount TD-3350-FM	each	80.00

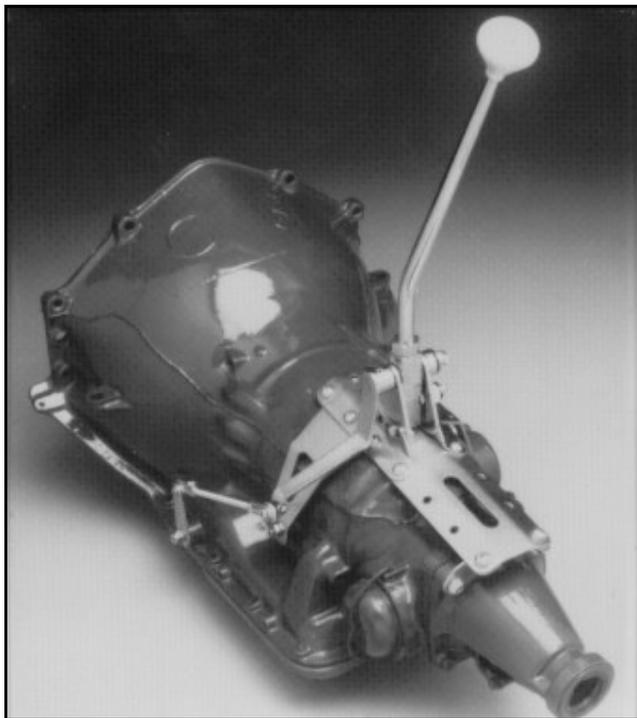

LOKAR TRANSMISSION SHIFTER

Available in 6" to 23" shaft length. Includes all hardware for installation. Specify Transmission type when ordering

6", 8", 10", 12" Shifter	each	259.00
16" Shifter	each	265.00
23" Shifter	each	275.00

Lokar offers a complete line of Emergency Brake Cables, Throttle Cables, Kick-Down Cables, Engine and Transmission Dip Sticks, and other related accessories. Call us for price and availability on all your Lokar needs.

1-800-543-5035



RECESSED FIREWALL

1948-52, All, 2" recessed, steel	
FD-220	each 385.00



RECESSED FIREWALL

1953-56, All, 4" recessed, steel	
FD-224	each 442.00



**1948-52
Front**



**1956
Front**

FRONT FLOOR PAN SECTION

1948-52, Front Cab Floor Pan, one piece, front section	
7C-8111106-S	each 185.00
1948-52, 1/2 Floor Pan, Left Side	
7C--8111106-L	each 80.00
1948-52, 1/2 Floor Pan, Right Side	
7C-8111106-R	per side 80.00
1953-55, Front Cab Floor Pan, Right or Left Side	
BAAA-8111106-S	per side 80.00
1956, Front Cab Floor Pan, Right or Left Side	
B6C-8111106-S	per side 80.00

SURE FIT SERIES
1953-1956 FORD F-100 TRUCK



F-100 Sure Fit's now Feature Gen-11 Technology!

Vintage Air Sure-Fit air conditioning, heating and defrost systems for 1953-56 Ford F-100 trucks are designed specifically for each application. Get true bi-level air flow and OEM quality "just right" temperature control.

Ford F-100 Gen-11 Sure Fit System Features:

Electronic Servo Motor Controls, including Heater Valve

Free shipping does not apply



The All-In-One Kit For Your Classic Ford Truck!

Complete Kit: Air conditioning, heating and defrost combination designed specifically for your vehicle. Original deluxe control assembly in your dash connects to and controls this unit. Designed to mount to existing holes in your dash and firewall without drilling or fabrication. Evaporator kit comes complete with all mounting brackets, hardware, louvers, duct hose, condenser, drier, wiring harness and installation instructions.

Note: Some installations may require additional engine pulleys not included with kits. You must provide v-belts and refrigerant.

Basic Kit 1295.00 (Upgrades Additional)



**1948-52 Pickup
Vintage Air Gen 11 Compac Kit
Not a "Sure-Fit" System**



Includes:

- Heat/Cool/Defrost System
- Hose Kit with Drier
- Compressor
- Condenser

**Basic Kit 1195.00
(Upgrades Additional)**

Does not include compressor mounting brackets

Free shipping does not apply



UNDER BED GAS TANKS

1948-56, Mounts to bottom of frame, 28"x16-1/2"x8", 16 gals., Aluminum, 1948-52 requires crossmember modification, includes pick-up tube, baffled, tig welded, pressure tested.

UB-9002 each 419.00



RECTANGULAR GAS DOOR

Mounts in bed floor, 4-1/4" x 5-1/2", Aluminum, smooth or Ball Milled

KUS-312515 Ball Milled each 90.00

KUS-312517 Smooth each 90.00



OVAL GAS DOOR

Mounts in bed floor, 4-1/4" x 6-1/2", Aluminum, smooth or Ball Milled

KUS-312516 Ball Milled each 90.00

KUS-312518 Smooth each 90.00



POP-UP FILLER CAP

Polished Billet Aluminum, Flush mount, 2-1/2" O.D.
KUS-312521 out of Production



FILLER CAP

Polished Stainless Steel, Flush mount, 3" O.D., w/key
KUS-9040 each 49.00



FILLER CAP INSTALLATION KIT

Fuel resistant hose with clamps for above Filler Caps
KUS-9060 each 16.00

GAS TANK MOUNTING KIT

Kit includes rubber mounting pads, stainless steel hardware for mounting under-bed tank to frame
KUS-9002-MK each 15.00





POWER WINDOW KITS

These kits include: 2 Regulator/Motor Assemblies, Wiring Harness and Conduit, your choice of GM Chrome or Black Illuminated Switches. These are bolt-in assemblies to replace your original regulators on both sides. It doesn't get any easier than this.



**KIT
\$450.00**

Part # 4852-NRPW

1948-52 FORD PICKUP

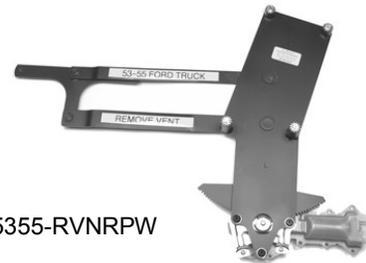

**KIT
\$595.00**

Part # 5355-RVNRPW

1953-55 FORD PICKUP TO REMOVE VENT

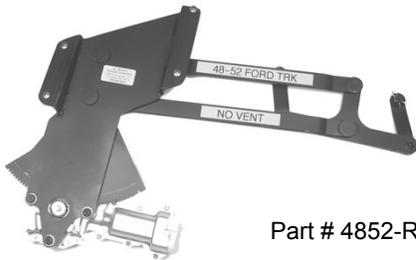

**KIT
\$595.00**

Part # 4852-RVNRPW

1948-52 FORD PICKUP TO REMOVE VENT



**KIT
\$450.00**

Part # 56-NRPW

1956 FORD PICKUP

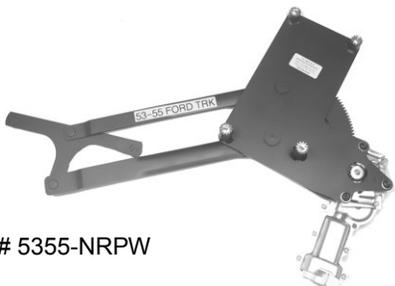

**KIT
\$450.00**

Part # 5355-NRPW

1953-55 FORD PICKUP



**KIT
\$595.00**

Part # 56-RVNRPW

1956 FORD PICKUP TO REMOVE VENT

1948-56 PICKUP GLASS



1948-52 GLASS

Complete Glass Set	set	349.00
Windshield Only	each	180.00
Back Glass Only	each	75.00
Vent Windows Only	pair	75.00
Door Windows Only	pair	95.00

Flat Rate Shipping for 48-52 Sets to Continental US 65.00



1953-55 GLASS

Complete Glass Set	set	425.00
Windshield Only	each	200.00
Back Glass Only	each	80.00
Vent Windows Only	pair	75.00
Door Windows Only	pair	95.00

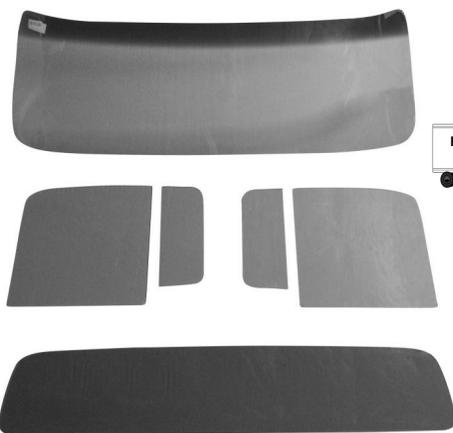

1956 GLASS

Complete Set (small back window).....	set	425.00
Windshield Only	each	200.00
Back Glass Only (Small)	each	80.00
Back Glass Only (Large)	each	299.00
Vent Windows Only	pair	75.00
Door Windows Only	pair	95.00

SPECIAL NOTES

- 1948-52 Specify Year For Correct Back Glass Size
- 1953-56 Complete Glass Sets, Windshields, and Large Back Glass Must Ship by Freight Truck
- Complete Pickup Glass Sets or Individual Pieces Available in Clear, Green, and Smoked
- Normal Shipping In 2-4 Business Days
- Windshields Available Clear or Shaded Across Top
- Many Other Years and Models Available. Call for Availability and Pricing

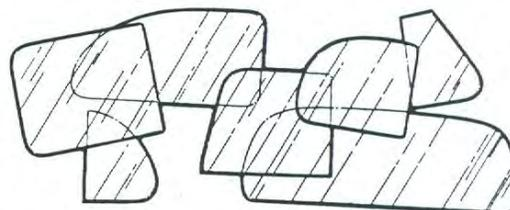

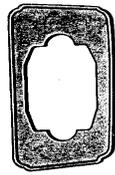
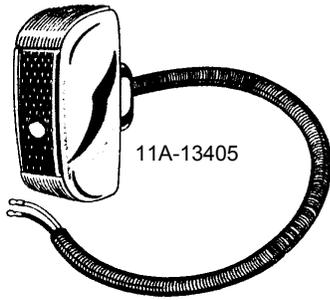

TAIL LAMPS

1948-56, Panel, Right Hand, Chrome Plated, Glass Lens		
11A-13405-R	each	65.00
1948-56, Panel, As Above, Left Hand		
11A-13405-L	each	65.00
1948-56, Tail Lamp Pads		
11A-13420	each	6.00



11A-13450-G

TAIL LAMP LENS

1948-56, Panel Truck, Glass		
11A-13450-G	each	8.00
1948-56, Panel Truck, glass with Blue Dot installed		
11A-13450-BD	each	16.00

TAIL LAMP LENS TO HOUSING GASKET

1948-56, Panel		
11A-13461	pair	3.00



DOOR HINGE PINS

1948-52		
1167-B	each	1.50
1948-52, Stainless Steel		
1167-BSS	each	3.00
1948-52, Stainless Steel, Oversize (.344)		
B-1167-OSS	each	7.00

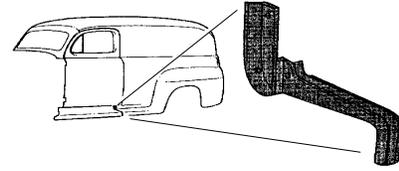

RUNNING BOARD TO REAR QUARTER PANEL RUBBER

1948-52, Panel		
7C-8227838-PR	pair	57.50
1953-56, Panel, Running Board to Body Seal		
BAAA-16540-C	pair	25.00
1948-52, Panel Only, Gas Neck Grommet		
7C-9080-P	each	25.00
1953-56, Panel Only, Gas Neck Grommet		
BAAA-9080-A	each	25.00
1948-56, Inside Rear Door Handle		
8M-7943426	each	15.00
1948-56 Panel, Rear Door Outside Handle		
7C-8226600-A	each	50.00
1948-56 Panel, Rear Outside Door Handle Pad		
BAAA-8222428-B	each	6.00
1948-52, Back Window Seals , a pair does both doors		
7C-8242084-P	pair	60.00
1953-56, As Above		
BAAA-8242084-P	pair	60.00
1948-52, Rear Door Seal Set , for both doors		
7C-8243722-PR	set	85.00
1953-56, As Above		
BAAA-8243722/3	set	75.00
1953-55, Roof Headliner Kit		
B5C-8251968-P	kit	120.00
1956, Roof Headliner Kit		
B6C-8251968-P	kit	120.00
1953-56, Roof Headliner Rubber Seal		
BAAA-8150956	each	18.50
1953-56, Roof Headliner Clip , 16pc. set		
BAAA-8150960	set	8.00
1948-56, License Plate Lamp Assembly		
8A-13556-A	each	30.00
1948-56, License Plate Lens		
7RA-13564	each	10.00
1948-56, Rear Door Dovetail		
81C-825950	each	25.00
1948-52, Rear Door Check Bumper		
01C-8244123	pair	3.00

BOOKS - MANUALS - LITERATURE

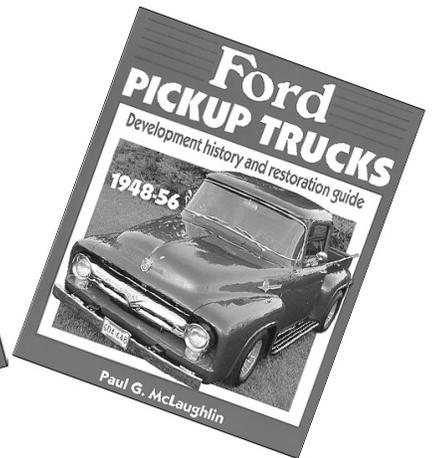
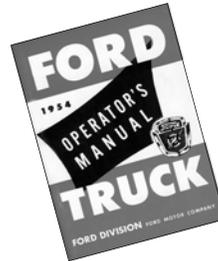
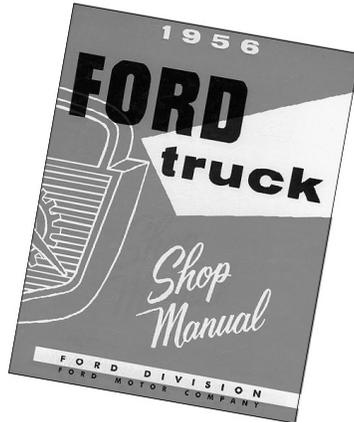
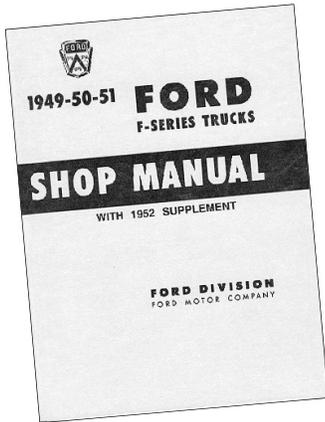

1948-50 Specification Features Manual		
TR-4801	each	10.00
1948 Operators Manual		
TR-4810	each	10.00
1948-56 Truck Chassis and Body Books - 2 volumes		
TR-4815-6	each	250.00
1948-52 Shop Manual		
TR-4900	each	30.00
1949-50 Ford Service Manual for Cars and Pickups		
CA-4902	each	10.00
1949 Operators Manual		
TR-4910	each	10.00
1950 Operators Manual		
TR-5010	each	10.00
1951-52 Specification Features Manual		
TR-5101	each	10.00
1951-52 Operators Manual		
TR-5110	each	18.00
1953 Specifications Features Manual		
TR-5301	each	10.00
1953-55 Radio Installing and Service Manual - Original Radio		
TR-5309	each	6.00
1953 Operators Manual		
TR-5310	each	10.00
1953 Shop Manual		
TR-5300	each	50.00

1954-55 Shop Manual		
TR-5400	each	30.00
1954 Specification Features Manual		
TR-5401	each	10.00
1954 Operators Manual		
TR-5410	each	10.00
1954-62 The Ford "Y" Block Book - Origin, Maintenance, Rebuild		
CA-5428	each	20.00
1955 Specification Features Manual		
TR-5501	each	10.00
1955 Operators Manual		
TR-5510	each	10.00
1956 Shop Manual		
TR-5600	each	30.00
1956 Specification Features Manual		
TR-5601	each	10.00
1956 Operators Manual		
TR-5610	each	10.00



Call ahead for free parts delivery to any of the shows below!

You'll find us at these Swap Meets

<u>DATE</u>	<u>CITY/STATE</u>	<u>LOCATION</u>
Feb. 1-2, 2019	Moultrie, GA	Spence Air Field
March 9-10, 2019	Louisville, KY	Exposition Center@ Row F, #17-24
March 21-23, 2019	Myrtle Beach, S.C.	Myrtle Square Mall
April 4-7, 2019	Charlotte, NC	Speedway @ YYB 157, Blue field
April 24-28, 2019	Carlisle, PA	Fairgrounds @ Q-25
May 3-5, 2019	Knoxville, TN	NSRA @ Chilhowee Park
May 16-18, 2019	Pigeon Forge, TN	F-100 Reunion
May 31-June 2, 2019	Carlisle, PA	Fairgrounds, All Ford Meet @Q-25
Aug. 1-4, 2019	Louisville, KY	NSRA Nationals @ Expo Center
Sept. 13-15, 2019	Kalamazoo, MI	NSRA at Fairgrounds
Sept. 19-21, 2019	Sevierville, TN	Sevierville Convention Center
Oct. 2-6, 2019	Carlisle, PA	Fairgrounds @ Q-25
Oct. 17-19, 2019	Charlotte Auto Fair	Concord, N.C. Speedway, CCO_12
Nov. 22-24, 2019	Moultrie, GA	Spence Air Field, E55-59
Nov. 28-Dec. 1, 2019	Daytona, FL	Turkey Run @ Daytona Spdwy., A-1

Email us at: MidwestEFS@core.com

Visit our Web Site: MidwestEarlyFord.com

1948-50 FORD TRUCK MODEL

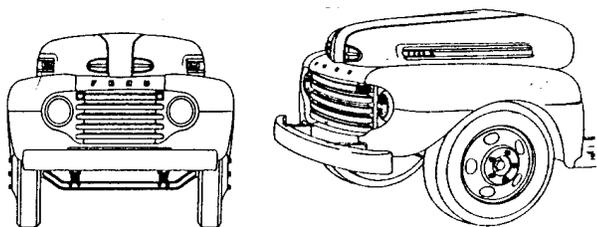

1951 FORD TRUCK MODEL

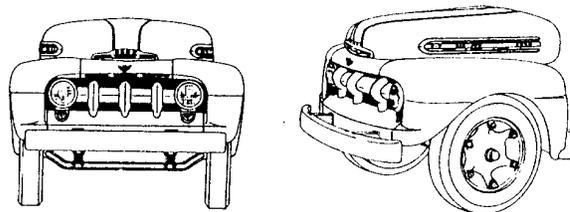

1952 FORD TRUCK MODEL

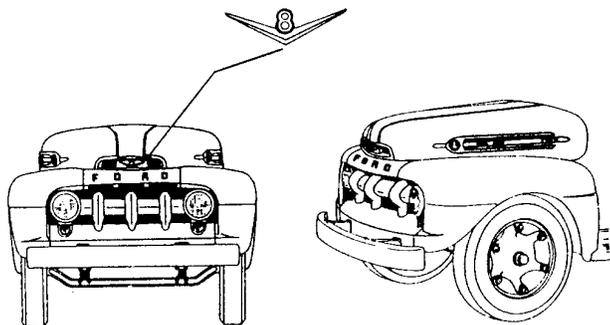

1953 FORD TRUCK MODEL

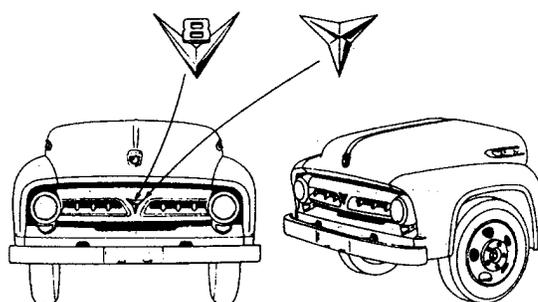

1954 FORD TRUCK MODEL

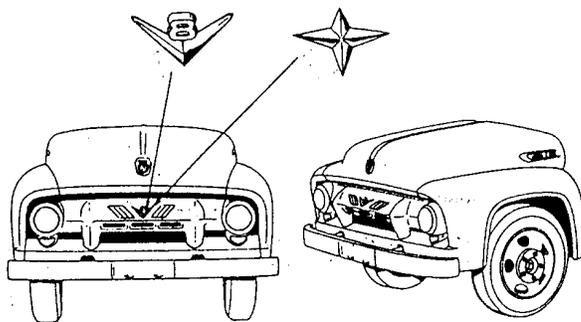

1955 FORD TRUCK MODEL

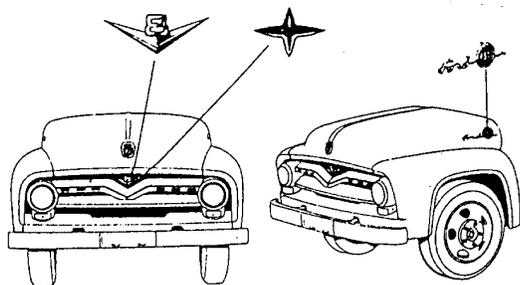

1956 FORD TRUCK MODEL

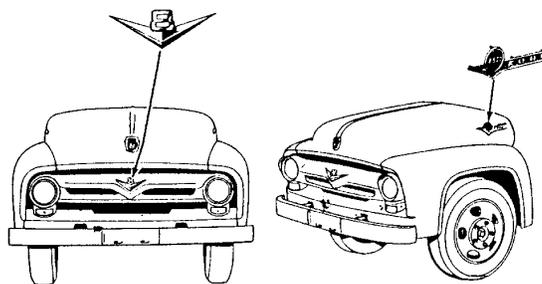

GENERAL REFERENCE PAGE

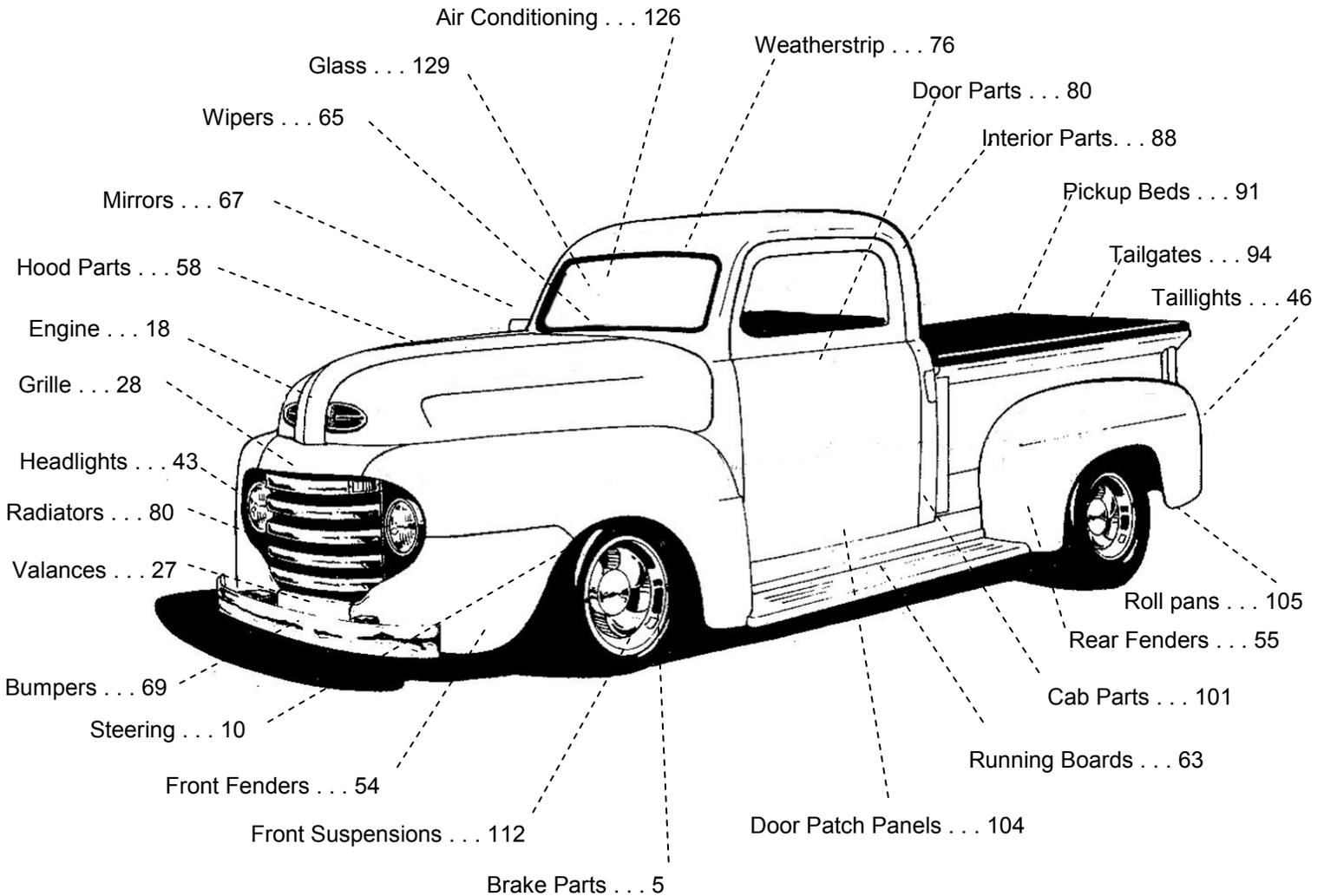

FREE SHIPPING

Pre-paid orders over \$1,000 are shipped free by UPS ground within the continental US. Free shipping does not apply to back orders, truck freight, UPS oversize (exceeding 48") or overweight items (exceeding 70 lbs.). Mail order customers please add required amounts for each oversize or overweight item. Over payments will be refunded or credited.

1-800-543-5035  **Springfield, OH**  **MidwestEarlyFord.com**

**Early Ford Reproduction Parts has other great catalogs
for Ford Cars and Trucks from 1928-56.
All catalogs 4.00 each. Call for your copy today!**



**1928-48
Car & Truck**

Other
Catalogs
Available

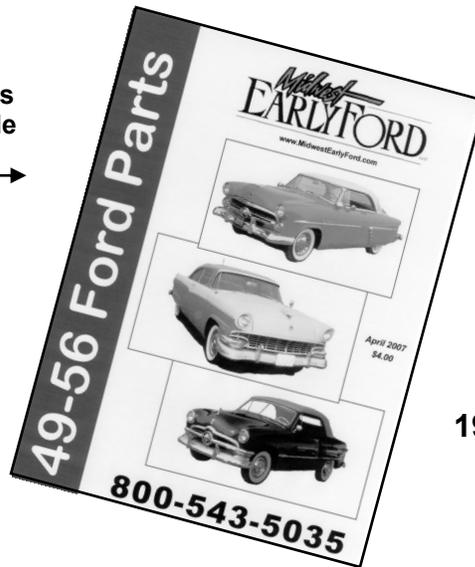

**1949-56
Car**

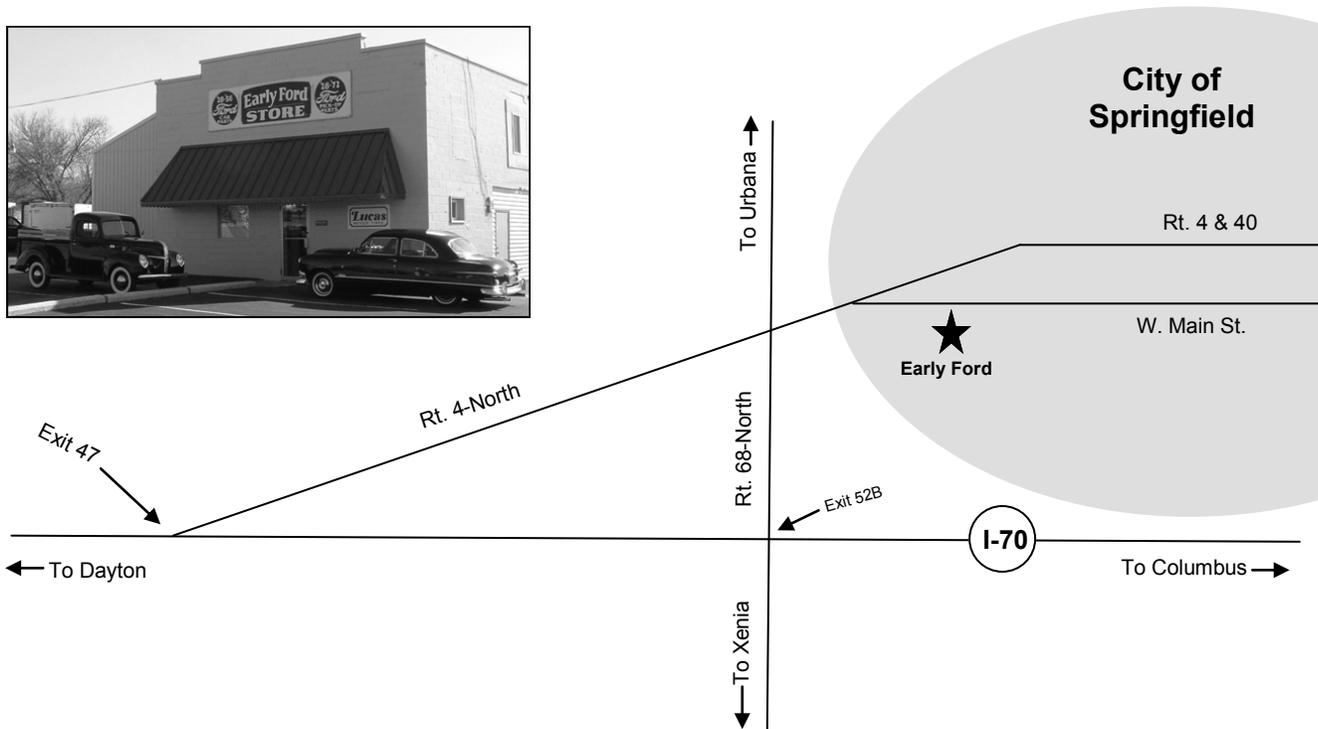

**2141 WEST MAIN STREET
SPRINGFIELD, OHIO 45504**

**Customer Service (937) 325-2408
Toll Free Orders Only (800) 543-5035
Fax (937) 325-1900**



Customer Service (937) 325-2408
Toll Free Orders Only (800) 543-5035
Fax (937) 325-1900

www.MidwestEarlyFord.com

Email: MidwestEFS@core.com

2141 West Main Street, Springfield, OH 45504



Swap Meet Schedule—Page 132

WALK-IN SALE

10% OFF ALL CASH SALES

Also 5% discount for credit card use during this sale only

Friday & Saturday, Sept. 6-7, 2019

This is a two day in-store sale and cannot be used with any other discounts



www.MidwestEarlyFord.com

TOLL FREE ORDERS ONLY PLEASE—800-543-5035

CUSTOMER SERVICE—937-325-2408

FAX—937-325-1900

MidwestEFS@core.com

2141 West Main Street, Springfield, OH 45504